

Service Manual

Blu-ray Disc Recorder

Model No. **DMR-BWT955GL**

Colour:

(S).....Silver Type



Notes: This model's BD Drive is SXY0018

**When replacing HDD, D-Audio P.C.B. or EEPROM
"HDD Error" indication is displayed and HDD must be
formatted.**

**After that, programme in the HDD will be lost.
In detail, please refer to each content in this service
manual.**

"AVCHD", "AVCHD 3D", "AVCHD Progressive" and "AVCHD 3D/Progressive" are trademarks of Panasonic Corporation and Sony Corporation.

Copyright 2004-2014 Verance Corporation. Cinavia™ is a Verance Corporation trademark. Protected by U.S. Patent 7,369,677 and worldwide patents issued and pending under license from Verance Corporation. All rights reserved.

DLNA, the DLNA Logo and DLNA CERTIFIED are trademarks, service marks, or certification marks of the Digital Living Network Alliance.

DVB and the DVB logos are trademarks of the DVB Project.

Manufactured under license from Dolby Laboratories.
Dolby and the double-D symbol are trademarks of Dolby Laboratories.



For DTS patents, see <http://patents.dts.com>. Manufactured under license from DTS Licensing Limited. DTS, DTS-HD, the Symbol, & DTS and the Symbol together are registered trademarks, and DTS-HD Master Audio | Essential is a trademark of DTS, Inc. © DTS, Inc. All Rights Reserved.



"DVD Logo" is a trademark of DVD Format/Logo Licensing Corporation.

MPEG Layer-3 audio coding technology licensed from Fraunhofer IIS and Thomson.

This product is licensed under the AVC patent portfolio license and VC-1 patent portfolio license for the personal and non-commercial use of a consumer to (i) encode video in compliance with the AVC Standard and VC-1 Standard ("AVC/VC-1 Video") and/or (ii) decode AVC/VC-1 Video that was encoded by a consumer engaged in a personal and non-commercial activity and/or was obtained from a video provider licensed to provide AVC/VC-1 Video. No license is granted or shall be implied for any other use. Additional information may be obtained from MPEG LA, LLC. See <http://www.mpegla.com>.

SDXC Logo is a trademark of SD-3C, LLC.

The Wi-Fi CERTIFIED™ Logo is a certification mark of Wi-Fi Alliance®.
The Wi-Fi Protected Setup™ Identifier mark is a certification mark of Wi-Fi Alliance®.



"Wi-Fi®" and "Wi-Fi Direct®" are registered trademarks of Wi-Fi Alliance®.
"Wi-Fi Protected Setup™", "Miracast™", "WPA™", and "WPA2™" are trademarks of Wi-Fi Alliance®.

HDMI, the HDMI Logo, and High-Definition Multimedia Interface are trademarks or registered trademarks of HDMI Licensing LLC in the United States and other countries.

Java is a registered trademark of Oracle and/or its affiliates.



Windows is a trademark or a registered trademark of Microsoft Corporation in the United States and other countries.

Android is a trademark of Google Inc.

This product incorporates the following software:
(1) the software developed independently by or for Panasonic Corporation,
(2) the software owned by third party and licensed to Panasonic Corporation,
(3) the software licensed under the GNU General Public License, Version 2.0 (GPL V2.0),
(4) the software licensed under the GNU LESSER General Public License, Version 2.1 (LGPL V2.1), and/or
(5) open source software other than the software licensed under the GPL V2.0 and/or LGPL V2.1.

The software categorized as (3) - (5) are distributed in the hope that it will be useful, but WITHOUT ANY WARRANTY, without even the implied warranty of MERCHANTABILITY or FITNESS FOR A PARTICULAR PURPOSE. Please refer to the detailed terms and conditions thereof shown in the Basic Settings menu.

At least three (3) years from delivery of this product, Panasonic will give to any third party who contacts us at the contact information provided below, for a charge no more than our cost of physically performing source code distribution, a complete machine-readable copy of the corresponding source code covered under GPL V2.0, LGPL V2.1 or the other licenses with the obligation to do so, as well as the respective copyright notice thereof.
Contact Information: oss-cd-request@gg.jp.panasonic.com

The source code and the copyright notice are also available for free in our website below.
<http://panasonic.net/avc/oss/>

MS/PlayReady/Final Product Labeling
This product contains technology subject to certain intellectual property rights of Microsoft. Use or distribution of this technology outside of this product is prohibited without the appropriate license(s) from Microsoft.

MS/PlayReady/End User Notices
Content owners use Microsoft PlayReady™ content access technology to protect their intellectual property, including copyrighted content. This device uses PlayReady technology to access PlayReady-protected content and/or WMDRM-protected content. If the device fails to properly enforce restrictions on content usage, content owners may require Microsoft to revoke the device's ability to consume PlayReady-protected content.
Revocation should not affect unprotected content or content protected by other content access technologies. Content owners may require you to upgrade PlayReady to access their content. If you decline an upgrade, you will not be able to access content that requires the upgrade.

Vorbis, FLAC, WPA Supplicant
The software licenses are displayed when "Software Licence" in the Basic Settings menu is selected.

WARNING

This service information is designed for experienced repair technicians only and is not designed for use by the general public. It does not contain warnings or cautions to advise non-technical individuals of potential dangers in attempting to service a product. Products powered by electricity should be serviced or repaired only by experienced professional technicians. Any attempt to service or repair the product or products dealt with in this service information by anyone else could result in serious injury or death.

TABLE OF CONTENTS

	PAGE		PAGE
1 Safety Precautions	5	12 Wiring Connection Diagram	86
1.1. General Guidelines	5	12.1. Interconnection Schematic Diagram	86
2 Warning	6		
2.1. Prevention of Electro Static Discharge (ESD) to Electrostatically Sensitive (ES) Devices	6		
2.2. Precaution of Laser Diode	7		
2.3. Service caution based on Legal restrictions	8		
3 Service Navigation	9		
3.1. External HDD (USB HDD)	9		
3.2. How to format for HDD when replacement of HDD or D-Audio P.C.B.	12		
3.3. Combination of Multiple Pressing on the Remote Control	13		
3.4. Entering Special Modes with Combination of Multiple Pressing on the Remote Control	13		
3.5. Micro Fuse conducting check	15		
3.6. Operation check when a USB device is connected	16		
3.7. (HDD/BD Drive) Service Navigation	17		
3.8. Wi-Fi Module (Internal) Malfunction Check (Simplified Method)	19		
3.9. Check with Tuner Service Mode	21		
3.10. Description of the Self Diagnosis <Operation Method, Details>	25		
4 Specifications	34		
5 Location of Controls and Components	36		
6 Installation Instructions	38		
6.1. Taking out the Disc from BD-Drive Unit when the Disc cannot be ejected by [OPEN/CLOSE] button	38		
7 Service Mode	39		
7.1. Self-Diagnosis and Special Mode Setting	39		
8 Service Fixture & Tools	59		
9 Disassembly and Assembly Instructions	60		
9.1. Disassembly flow chart	60		
9.2. P.C.B. Positions	60		
9.3. Top Ornament Ass'y	61		
9.4. Top Case	61		
9.5. Front Panel Ass'y	62		
9.6. Wi-Fi Module, HDD and HDD BRIDGE P.C.B.	63		
9.7. BD Drive	65		
9.8. Rear Panel and Fan Motor	65		
9.9. Main P.C.B.	66		
9.10. D-AUDIO P.C.B.	66		
9.11. Digital P.C.B.	66		
9.12. BD Drive	66		
10 Measurements and Adjustments	73		
10.1. Service Positions	73		
10.2. Caution for Replacing Parts	78		
10.3. Standard Inspection Specifications after Making Repairs	79		
11 Block Diagram	80		
11.1. Power Supply Block Diagram	80		
11.2. Analog Audio and Video Block Diagram	81		
11.3. Analog Timer Block Diagram	82		
11.4. Digital P.C.B. Block Diagram (1/2)	83		
11.5. Digital P.C.B. Block Diagram (2/2)	84		
11.6. Digital P.C.B. Regulator Block Diagram	85		

1 Safety Precautions

1.1. General Guidelines

1. When servicing, observe the original lead dress. If a short circuit is found, replace all parts which have been overheated or damaged by the short circuit.
2. After servicing, see to it that all the protective devices such as insulation barriers, insulation papers shields are properly installed.
3. After servicing, make the following leakage current checks to prevent the customer from being exposed to shock hazards.

1.1.1. Leakage Current Cold Check

1. Unplug the AC cord and connect a jumper between the two prongs on the plug.
2. Measure the resistance value, with an ohmmeter, between the jumpered AC plug and each exposed metallic cabinet part on the equipment such as screwheads, connectors, control shafts, etc. When the exposed metallic part has a return path to the chassis, the reading should be between $1M\Omega$ and $5.2M\Omega$.

When the exposed metal does not have a return path to the chassis, the reading must be ∞ .

1.1.2. Leakage Current Hot Check (See Figure 1.)

1. Plug the AC cord directly into the AC outlet. Do not use an isolation transformer for this check.
2. Connect a $1.5k\Omega$, 10 watts resistor, in parallel with a $0.15\mu F$ capacitors, between each exposed metallic part on the set and a good earth ground such as a water pipe, as shown in Figure 1.
3. Use an AC voltmeter, with 1000 ohms/volt or more sensitivity, to measure the potential across the resistor.
4. Check each exposed metallic part, and measure the voltage at each point.
5. Reverse the AC plug in the AC outlet and repeat each of the above measurements.
6. The potential at any point should not exceed 0.75 volts RMS. A leakage current tester (Simpson Model 229 or equivalent) may be used to make the hot checks, leakage current must not exceed 1/2 milliamp. In case a measurement is outside of the limits specified, there is a possibility of a shock hazard, and the equipment should be repaired and re-checked before it is returned to the customer.

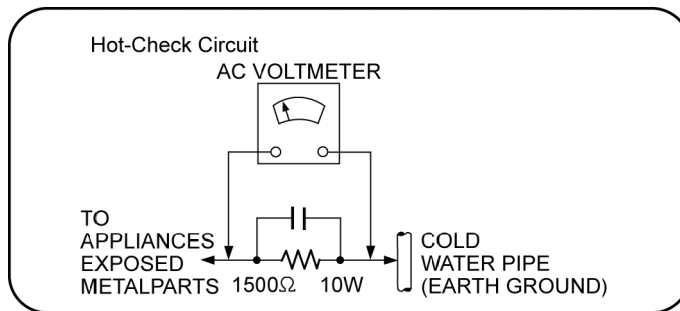

Fig. 1

2 Warning

2.1. Prevention of Electro Static Discharge (ESD) to Electrostatically Sensitive (ES) Devices

Some semiconductor (solid state) devices can be damaged easily by static electricity. Such components commonly are called Electrostatically Sensitive (ES) Devices. Examples of typical ES devices are integrated circuits and some field-effect transistors and semiconductor “chip” components. The following techniques should be used to help reduce the incidence of component damage caused by electrostatic discharge (ESD).

1. Immediately before handling any semiconductor component or semiconductor-equipped assembly, drain off any ESD on your body by touching a known earth ground. Alternatively, obtain and wear a commercially available discharging ESD wrist strap, which should be removed for potential shock reasons prior to applying power to the unit under test.
2. After removing an electrical assembly equipped with ES devices, place the assembly on a conductive surface such as aluminium foil, to prevent electrostatic charge build up or exposure of the assembly.
3. Use only a grounded-tip soldering iron to solder or unsolder ES devices.
4. Use only an anti-static solder remover device. Some solder removal devices not classified as “anti-static (ESD protected)” can generate electrical charge sufficient to damage ES devices.
5. Do not use freon-propelled chemicals. These can generate electrical charges sufficient to damage ES devices.
6. Do not remove a replacement ES device from its protective package until immediately before you are ready to install it. (Most replacement ES devices are packaged with leads electrically shorted together by conductive foam, aluminium foil or comparable conductive material).
7. Immediately before removing the protective material from the leads of a replacement ES device, touch the protective material to the chassis or circuit assembly into which the device will be installed.

Caution:

Be sure no power is applied to the chassis or circuit, and observe all other safety precautions.

8. Minimize bodily motions when handling unpackaged replacement ES devices. (Otherwise harmless motion such as the brushing together of your clothes fabric or the lifting of your foot from a carpeted floor can generate static electricity sufficient to damage an ES device).

IMPORTANT SAFETY NOTICE

There are special components used in this equipment which are important for safety. These parts are marked by Δ in the schematic diagrams, Exploded Views and replacement parts list. It is essential that these critical parts should be replaced with manufacturer's specified parts to prevent shock, fire, or other hazards. Do not modify the original design without permission of manufacturer.

2.2. Precaution of Laser Diode

CAUTION :

This product utilizes a laser diode with the unit turned "ON", invisible laser radiation is emitted from the pick up lens.

Wave length : 661 nm(DVDs)/783 nm(CDs)/405nm(BDs)

Maximum output radiation power from pick up : 100 μ W/VDE

Laser radiation from pickup unit lens is safety level, but be sure the followings:

1. Do not disassemble the optical pickup unit, since radiation from exposed laser diode is dangerous.
2. Do not adjust the variable resistor on the pickup unit. It was already adjusted.
3. Do not look at the focus lens using optical instruments.
4. Recommend not to look at pickup lens for a long time.

ACHTUNG :

Dieses Produkt enthält eine Laserdiode. Im eingeschalteten Zustand wird unsichtbare Laserstrahlung von der Lasereinheit abgestrahlt.

Wellenlänge : 661 nm(DVDs)/783 nm(CDs)/405nm(BDs)

Maximale Strahlungsleistung der Lasereinheit : 100 μ W/VDE

Die Strahlung der Lasereinheit ungefährlich, wenn folgende Punkte beachtet werden:

1. Die Lasereinheit nicht zerlegen, da die Strahlung an der freigelegten Laserdiode gefährlich ist.
2. Den werkseitig justierten Einstellregler der Lasereinheit nicht verstellen.
3. Nicht mit optischen Instrumenten in die Fokussierlines blicken.
4. Nicht über längere Zeit in die Fokussierlines blicken.

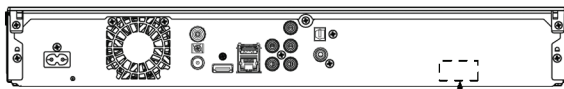

DANGER	VISIBLE AND INVISIBLE LASER RADIATION WHEN OPEN. AVOID DIRECT EXPOSURE TO BEAM. FD#21 CFR CLASS IIIb
CAUTION	CLASS 3B VISIBLE AND INVISIBLE LASER RADIATION WHEN OPEN. AVOID EXPOSURE TO THE BEAM. IEC60825-1 CLASS 3B
ATTENTION	RAYONNEMENT LASER VISIBLE ET INVISIBLE, CLASSE 3B, EN CAS D'OUVERTURE. EVITER UNE EXPOSITION AU FAISCEAU.
FORSIGTIG	SYNLIG OG OSYNLIG LASERSTRÅLING KLASSE 3B. NÅR LÅGET ER ÅBENT, UNDGÅ AT BLIVE UDSAT FOR STRÅLEN.
VARO	AVATTARESSA OLET ALTTIINA LUOKAN 3B NÄKYVÄÄ JA NÄKYMÄTÖNTÄ LASERSÄTEILYÄ. VARO ALTISTUMISTA SÄTEELLE.
VARNING	KLASS 3B SYNLIG OCH OSYNLIG LASERSTRÅLNING NÄR DENNA DEL ÄR ÖPPNAD. UNDVIK EXPONERING FÖR STRÅLEN.
VORSICHT	SICHTBARE UND UNSICHTBARE LASERSTRAHLUNG KLASSE 3B. WENN ABDECKUNG GEÖFFNET, NICHT DEM STRAHL AUSSETZEN.
注意	打开时有可见及不可见激光辐射。避免光束照射。
注意	ここを開くとクラス3Bの可視及び不可視レーザー放射が出る。ビームの目又は皮膚への接触は危険! 死んだり焼けたりしないこと
	VQL2Q40

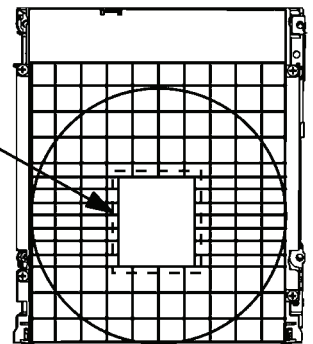

CAUTION!
THIS PRODUCT UTILIZES A LASER.
USE OF CONTROLS OR ADJUSTMENTS OR PERFORMANCE OF PROCEDURES OTHER THAN THOSE SPECIFIED HEREIN MAY RESULT IN HAZARDOUS RADIATION EXPOSURE.

2.3. Service caution based on Legal restrictions

2.3.1. General description about Lead Free Solder (PbF)

The lead free solder has been used in the mounting process of all electrical components on the printed circuit boards used for this equipment in considering the globally environmental conservation.

The normal solder is the alloy of tin (Sn) and lead (Pb). On the other hand, the lead free solder is the alloy mainly consists of tin (Sn), silver (Ag) and Copper (Cu), and the melting point of the lead free solder is higher approx.30 degrees C (86°F) more than that of the normal solder.

Definition of PCB Lead Free Solder being used

The letter of "PbF" is printed either foil side or components side on the PCB using the lead free solder. (See right figure)	PbF
---	------------

Service caution for repair work using Lead Free Solder (PbF)

- The lead free solder has to be used when repairing the equipment for which the lead free solder is used.
(Definition: The letter of "PbF" is printed on the PCB using the lead free solder.)
- To put lead free solder, it should be well molten and mixed with the original lead free solder.
- Remove the remaining lead free solder on the PCB cleanly for soldering of the new IC.
- Since the melting point of the lead free solder is higher than that of the normal lead solder, it takes the longer time to melt the lead free solder.
- Use the soldering iron (more than 70W) equipped with the temperature control after setting the temperature at 350±30 degrees C (662±86°F).

Recommended Lead Free Solder (Service Parts Route.)

- The following 3 types of lead free solder are available through the service parts route.
SVKZ000001----- (0.3mm 100g Reel)
SVKZ000002----- (0.6mm 100g Reel)
SVKZ000003----- (1.0mm 100g Reel)

Note

*Ingredient: Tin (Sn) 96.5%, Silver (Ag) 3.0%, Copper (Cu) 0.5%. (Flux cored)

3 Service Navigation

3.1. External HDD (USB HDD)

Please use a confirmed USB HDD

For the latest information on confirmed USB HDDs, please check the following website.
<http://panasonic.jp/support/global/cs/>

- Certain non-confirmed USB HDDs cannot be used with this unit.
- If a problem occurs with the USB HDD, please contact the manufacturer of the device.

3.1.1. Connecting the USB HDD

Connect this unit with optional USB HDD.

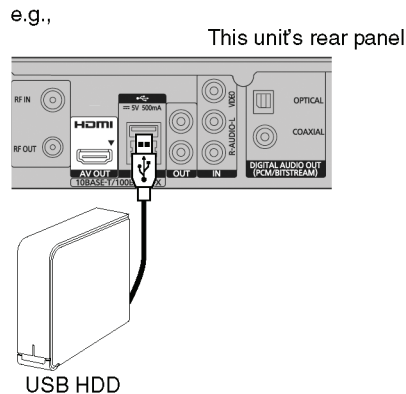

- Only one USB HDD can be connected at the same time.
- Do not connect additional HDDs using a USB hub.
- For details about connection method, refer to the instructions supplied with the USB HDD.

3.1.2. Disconnecting the USB HDD

Please use the following procedure to disconnect.

Disconnecting without following this procedure may result in the loss of recorded content from the USB HDD or the internal HDD.

1. Press [FUNCTION MENU].
2. Select "Basic Settings" in "Setup", then press [OK].
3. Select "Settings for USB HDD" in "HDD/ Disc/ USB HDD", then press [OK].
4. Select "USB HDD Disconnection", then press [OK].
5. Select "Yes", then press [OK].
6. Disconnect the USB HDD from this unit.

3.1.3. Registering the USB HDD

3.1.3.1. Registering the USB HDD

- If you intend to move recorded titles to a USB HDD, the USB HDD must be registered to this unit first.

Limitation information:

- A USB HDD with a capacity of less than 160 GB cannot be used.
- Registering of a USB HDD will format the USB HDD and all the content already recorded will be deleted.
- Up to eight USB HDDs can be registered on this unit.
- Registered USB HDDs cannot be used with devices other than this unit.

- If the registering screen appears when connecting the USB HDD, go to step 5.

1. Press [FUNCTION MENU].
2. Select "Basic Settings" in "Setup", then press [OK].
3. Select "Settings for USB HDD" in "HDD/ Disc/ USB HDD", then press [OK].
4. Select "USB HDD Registration", then press [OK].
5. Select "Yes", then press [OK].

- If you have already registered eight USB HDDs, it will be necessary to delete one or more of them before registering a new USB HDD.

The message screen appears:

- a. Select "Yes", then press [OK].
- b. Select the USB HDD to cancel, then press [OK]. The confirmation screen appears.

- c. Select "Yes", then press [OK].
- 6. When the registering is complete, message screen appears.
Press [OK].
- 7. The confirmation screen appears.
Press [OK].

3.1.3.2. Settings for USB HDD

Delete all titles

Delete all titles on the USB HDD.

- Delete does not work if one or more titles are protected.

1. Press [FUNCTION MENU].
2. Select "Basic Settings" in "Setup", then press [OK].
3. Select "Settings for USB HDD" in "HDD/ Disc/ USB HDD", then press [OK].
4. Select "USB HDD Management", then press and hold [OK] for 3 seconds.
5. Select "Delete all titles", then press [OK].
6. Select "Yes" and press [OK].
7. Select "Start" and press [OK].
8. The confirmation screen appears, then press [OK].

Format USB HDD

Formatting deletes all contents, and they cannot be restored.

- Check carefully before proceeding.

1. Press [FUNCTION MENU].
2. Select "Basic Settings" in "Setup", then press [OK].
3. Select "Settings for USB HDD" in "HDD/ Disc/ USB HDD", then press [OK].
4. Select "USB HDD Management", then press and hold [OK] for 3 seconds.
5. Select "Format USB HDD", then press [OK].
6. Select "Yes" and press [OK].
7. Select "Start" and press [OK]. Then formatting starts.
8. Press [OK] after formatting completed.

3.1.3.3. To cancell all USB HDD registrations

- If you register a USB HDD, all the content already recorded on the USB HDD will be deleted.
- It is not possible to play back the content on the USB HDD whose registration has been cancelled.
- You can check the registration number of the USB HDD on the DIRECT NAVIGATOR.

Cancellation of all USB HDD Registrations

This function cancels the registrations of all the USB HDDs registered on this unit.

Only do this if you are going to dispose of this unit.

- Before operation, perform "3.1.2. Disconnecting the USB HDD" and remove the USB HDD.

- It is not possible to play back the content from a USB HDD whose registration has been cancelled.

1. Press [FUNCTION MENU].
2. Select "Basic Settings" in "Setup", then press [OK].
3. Select "Settings for USB HDD" in "HDD/ Disc/ USB HDD", then press [OK].
4. Select "Cancellation of all USB HDD Registrations", then press and hold [OK] for 3 seconds.
5. Select "Yes", then press [OK].
6. The confirmation screen appears.
Select "Yes", and press [OK].
7. When the cancellation is complete, message screen appears.
Press [OK].

3.1.3.4. Registration procedure for USB HDD for inspection

This function registers a USB HDD for inspection aside from 8 USB HDDs that can be registered in Normal mode.

If the USB HDD for inspection is registered in User mode, it cannot be erased. Make sure to use Special mode to register the USB HDD for inspection.

Registration procedure

1. Perform "3.4.3. Nondisclosure mode 2" to enter the Service mode.
2. Press the [7][4] buttons of remote control in the Service mode to enter the Special mode.
3. If the new USB HDD is connected, it is automatically formatted/registered. (There is no TV monitor display for registration.)
The USB HDD registered in the Special mode can be operated using the same functions (format, record/play/edit, dubbing) as those for USB HDDs registered in the Normal mode.
The Special mode can be cancelled at power "OFF" only. (Cancelling the Special mode will erase the registration in the Special mode.)

3.1.4. Operation check when USB HDD is connected

Check the operation status (normal or abnormal) of the USB connection part as follows.

1. Press [FUNCTION MENU].
2. Select "Basic Settings" in "Setup", then press [OK].
3. Select "Settings for USB HDD" in "HDD/ Disc/ USB HDD", then press [OK].
4. Select "USB HDD Registration", then press [OK].

Normal operation:

The registered USB HDD is automatically displayed when connected.

(*Displayed items differ depending on the connected USB HDD.)

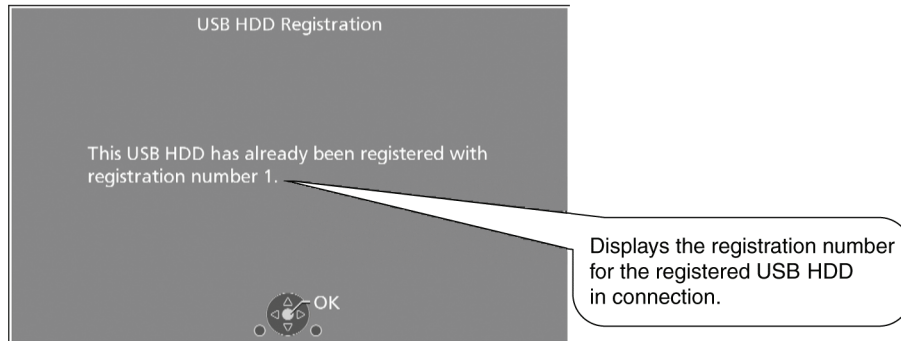

Abnormal operation (1):

When the USB HDD cannot be detected, "Cannot detect USB HDD." etc. will be automatically displayed.

(*When the cable (USB cable) between the main unit and the USB HDD is poorly connected (cable disconnection), etc.)

Abnormal operation (2):

When a wrong USB HDD incompatible with this unit is connected, "Connected USB device cannot be used with this unit.", etc. will be automatically displayed.

(*Incompatible USB HDD: When devices with capacity of less than 160GB or more than 3TB or other USB devices are connected)

Abnormal operation (3):

When more than 1 USB HDD are connected at the same time, "Registration of USB HDD must be done with only one USB storage device connected.", etc. will be automatically displayed.

Abnormal operation (4):

When a USB HDD compatible only with USB 1.1 or below is connected, "Connected USB device cannot be used with this unit.", etc. will be automatically displayed.

3.2. How to format for HDD when replacement of HDD or D-Audio P.C.B.

3.2.1. How to escape "HDD Error" indication on GUI display.

1. When exchange HDD or D-Audio P.C.B., the " HDD Error " screen is displayed, but, according to a following procedure, please format HDD.

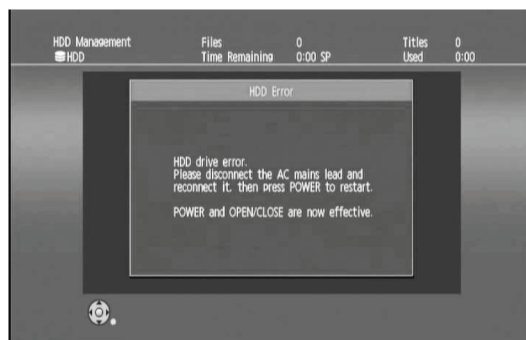

2. Turn off the power button first, then turn on the power with the " GUIDE " button on remote-controller. (Shown in Reference screen 1)

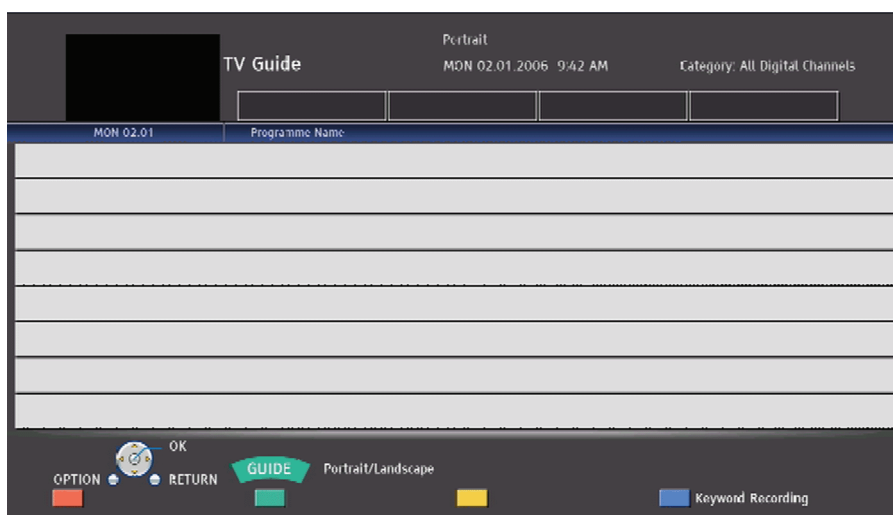

Reference screen 1

3. Turn on the "RETURN" button next, move to the normal display.

3.2.2. Procedure of the "HDD format".

1. Press [FUNCTION MENU].
2. Select " Setup " and press [OK].
3. Select "Basic Settings" and press [OK].
4. Select "HDD / Disc / USB HDD" and press [OK].
5. Select " HDD Management " and press [OK] for 3 seconds.
6. Select " Format HDD " and press [OK].
7. Select " Yes " and press [OK].
8. Select " Start " and press [OK]. Then formatting starts.
9. Press [OK] after formatting completed.
10. Press [RETURN] to exit setting mode.

3.3. Combination of Multiple Pressing on the Remote Control

Press multi-buttons (in combination) on the remote control simultaneously for operations, such as initialization or service mode, etc. There are no multiple pressing functions on the previous remote controls, thus, please be sure to use the supplied remote control.

3.4. Entering Special Modes with Combination of Multiple Pressing on the Remote Control

Enter the following special modes by multiple pressing functions on the supplied remote control. After entering each mode, switch to the desired menus for operation.

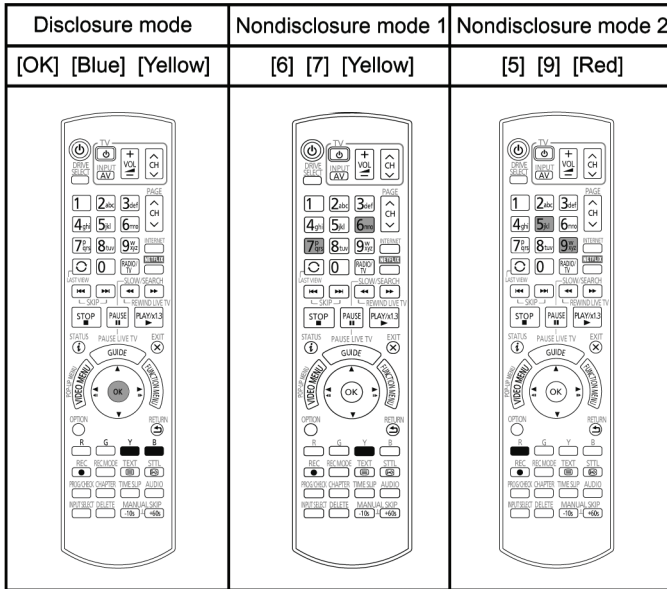

◆ **Menu switch:** ↓ mark.
[▶] (remote control),
or
[Power] (main unit)

◆ **Operating menu:**
[OK] (remote control)
or
[O/C] (main unit)

※ Release from special modes automatically after the operation.

◆ **Release from special modes:**

- Press other buttons in no connection with the above operations.
- No operation for over 2 min.
- Press and hold [Power] on main unit (forced to turn off).

3.4.1. Disclosure mode (Combination of multiple pressing: [OK] [Blue] [Yellow])

Press and hold [OK] [Blue] [Yellow] on the remote control simultaneously for 5 sec., then "00 RET" is displayed on FL display window.

Power	Disc	FL display	Key operation	Function	Remarks
OFF	Yes/No	00 RET	No	No	
		06 FT0	OK	Force tray open	When [O/C] button is invalid, the tray of BD Drive is forced to open. If the tray still cannot be opened in this mode, please refer to "6.1.2 When the Forcible Disc Eject can not be done".
ON	Yes/No	00 RET	No	No	
	No	03 VL	OK	Release from BD/DVD video play restriction	Release from the aging restriction on BD video and DVD video play.
	Yes/No	04 PRG	OK (Press and hold)	Progressive initialization	Initialize the progressive settings, and switch to the interlaced display. Press and hold [STOP] (not [OK])(on the remote control or main unit) to switch to "10 OCL" (setting shop lock mode)
	Yes/No	05 P/N	OK (Press and hold)	Switch the TV System	It returns to the default side (PAL). The change of PAL and NTSC can be performed in the following procedure. The unit's TV System is different from that of the disc. While stopped, keep pressing [STOP] and [OPEN/CLOSE] on the main unit for 5 or more seconds. The system switches from PAL to NTSC or vice versa.
	Yes/No	07 DC	OK (Press and hold)	Deep Color initialization	Initialize Deep Color.
	Yes	10 OCL	OK	Shop lock mode setting/release ([O/C] is invalid/valid, while setting/release this mode.)	When "04 PRG" is displayed, press and hold [STOP] (on the remote control or main unit) to switch to other displays. Press [OK] to only lock the tray switch. *Even turn ON/OFF the power, it is still in locking.

3.4.2. Nondisclosure mode 1 (Combination of multiple pressing: [6] [7] [Yellow])

Press and hold [6] [7] [Yellow] on the remote control simultaneously for 5 sec., then "50 RET" is displayed on FL display window.

Power	Disc	FL display	Key operation	Function	Remarks
ON	Yes/No	50 RET	No	No	
		↓			
		51 NOP	OK	No	When "51 NOP" is displayed, press and hold [STOP] (on the remote control or main unit) to switch to "52 BRE" (delete BD-ROM history settings).
		52 BRE	OK	BD-ROM history delete	When "51 NOP" is displayed, press and hold [STOP] (on the remote control or main unit) to switch to other displays. Press [OK] to delete BD-ROM history settings.

3.4.3. Nondisclosure mode 2 (Combination of multiple pressing: [5] [9] [Red])

Press and hold [5] [9] [Red] on the remote control simultaneously for about 5 sec., then "70 RET" is displayed on FL display window.

Power	Disc	FL display	Key operation	Function	Remarks
OFF	Yes/No	70 RET	No	No	
		↓			
		80 SRV	OK	Switch to service mode	Press [OK], then "HELLO" is displayed, and wait about 30 sec. until "SERV" is displayed.
		↓			
		83 SDI	OK	CD/SD Diag	Do not apply in normal service.
ON	Yes/No	91 SPD	OK	Special display	Do not apply in normal service.
		↓			
		92 F99	OK	F99 Validate/Invalidate switch	Do not apply in normal service.
		↓			
		70 RET	No	No	
		↓			
		81 AIG	OK	Switch to aging mode	
		↓			
82 TSR	OK	Switch to tuner service mode			
↓					
83 SDI	OK	CD/SD Diag	Do not apply in normal service.		
↓					
91 SPD	OK	Special display	Do not apply in normal service.		
↓					
92 F99	OK	F99 Validate/Invalidate switch	Do not apply in normal service.		
↓					
93 FIN	OK (Press and hold)	CS reset	Press [OK], then "FACT" is displayed, and the power will turn off automatic.		
↓					
96 DIC	OK	Diagnosis Code display	Press [OK], then "Diagnosis in progress. Please Wait." is displayed, and the Diagnosis Code will be displayed.		

3.5. Micro Fuse conducting check

This unit uses the Micro Fuse.

Check the Micro Fuse conducting using the Tester at the check points below.

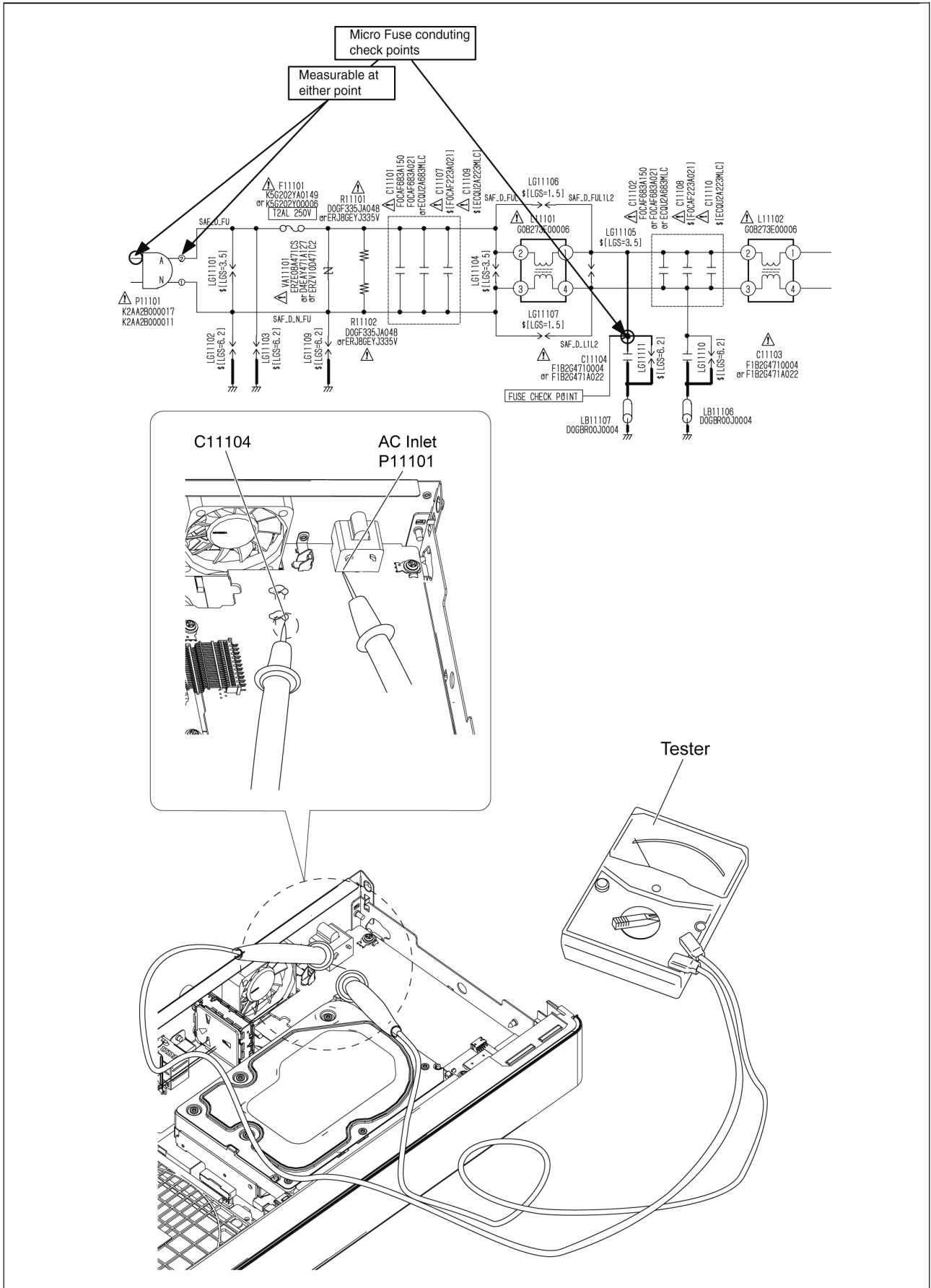

3.6. Operation check when a USB device is connected

You can check the operation status (normal or abnormal) of the USB connection part of this unit easily as shown below. Connect each device to the USB terminal on the front panel and check the operation status on the TV monitor.

Normal operation:

Automatically displayed when the USB connection is made to a digital camera, etc.

(Example below: When JPEG materials have been recorded)

(*Displayed items differ depending on the recorded contents.)



Abnormal operation (Example 1):

Warning is displayed automatically if overcurrent is detected when a USB device is connected.

(*When a USB device or this unit's USB terminal shorts out or the power supply type of USB device is connected)



Abnormal operation (Example 2):

When the terminal of USB device is damaged or open, there is no display on the TV monitor.

3.7. (HDD/BD Drive) Service Navigation

3.7.1. HDD/BD Drive Malfunction check (Simplified Method)

Perform simple quality judgement process of HDD/BD Drive according to the following operations.

1. Execute Service Mode
 - a. Turn the power off.
 - b. Press the [5] [9] and [R] button simultaneously for five seconds, then [70 RET] is displayed on FL.
 - c. Press the [▶] button to select until [80 SRV] is displayed on FL.
 - d. Press the [OK] button.
 - e. It is displayed on FL as [HELLO → SERV]:It is shown to have entered the service mode.
2. Press [3] [8] of remote controller keys in service mode.
3. Judge the quality on FL display.

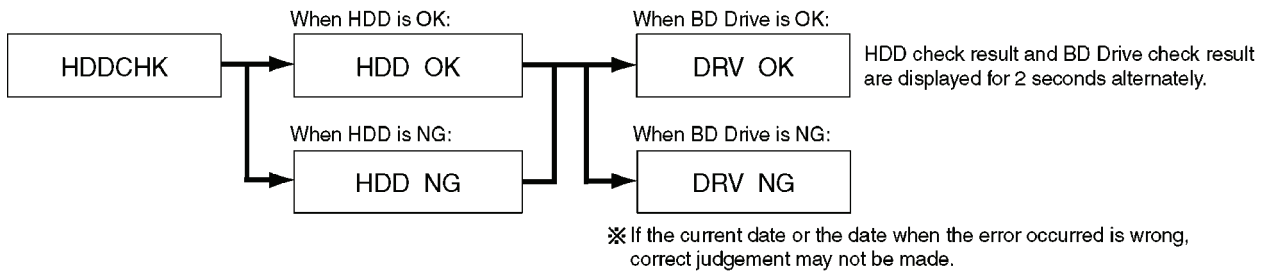

3.7.2. BD Drive Operation check flow

Perform quality judgement process of BD Drive according to the following operation.

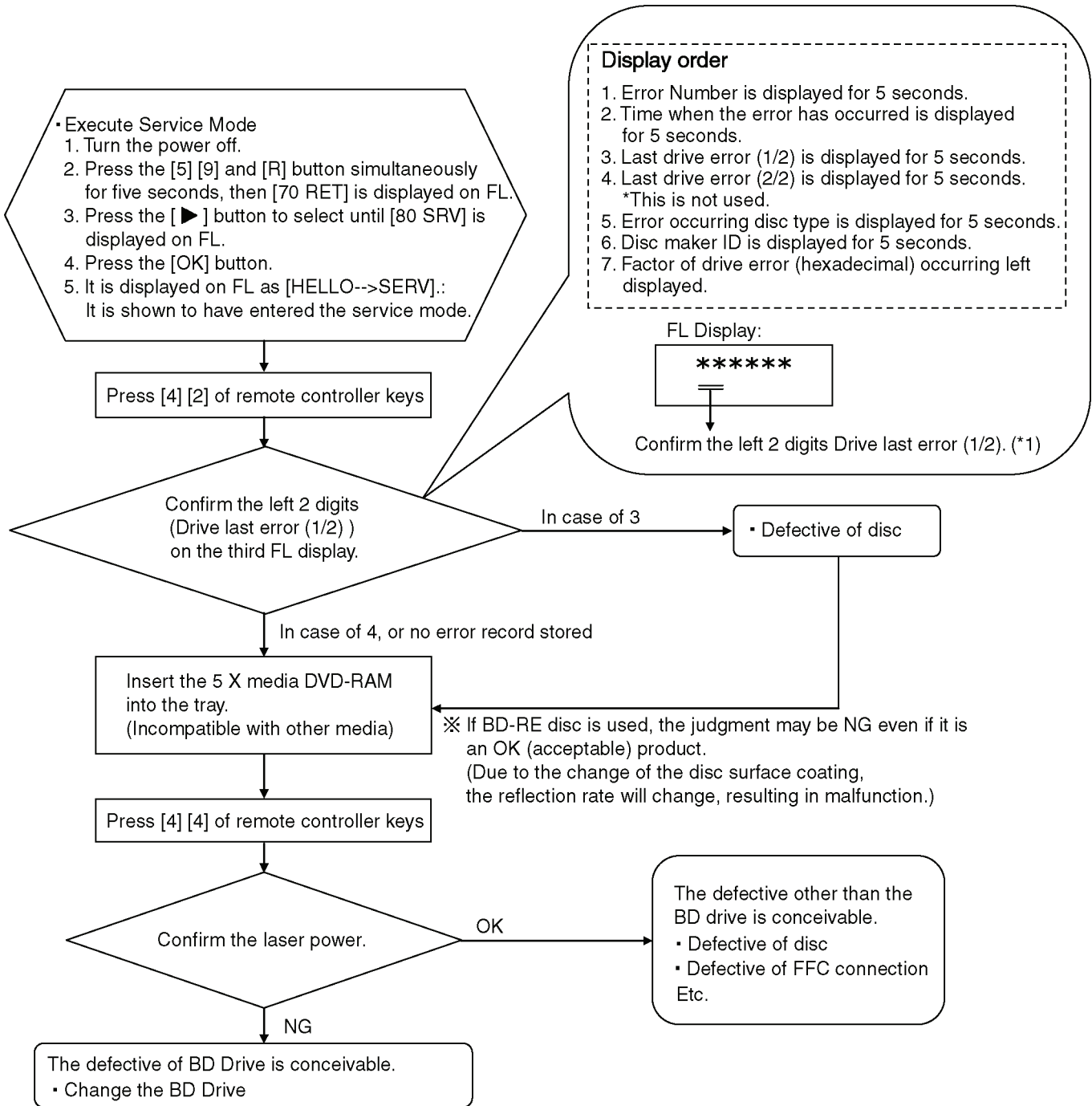

*1: The drive supports the following error sense keys:

Contents	Sense key	Description
NO SENSE	00	Successful completion.
RECOVERED ERROR	01	Successful completion through recovery.
NOT READY	02	The drive is unable to access the disc.
MEDIUM ERROR	03	An error caused by medium error has occurred.
HARDWARE ERROR	04	An error caused by the drive hardware has occurred.
ILLEGAL REQUEST	05	The CDB or parameter is illegal.
UNIT ATTENTION	06	The drive is alerting the host to some event.
DATA PROTECTED	07	The disc is read-protected or write-protected.
ABORTED COMMAND	0B	The drive has aborted an I/O process or command execution due to a reason not relevant to any other sense key, for example, a protocol violation on the interface.

3.8.1.3. Confirm method of Wireless LAN Module invalidity/effective

1. Press [FUNCTION MENU].
2. Select "Basic Settings" in "Setup", then press [OK].
3. Select "Display" and press [OK].
4. Press [STATUS], over than 5 seconds. The following "Display screen (example)" is displayed.
In case of Wireless LAN Module effective.

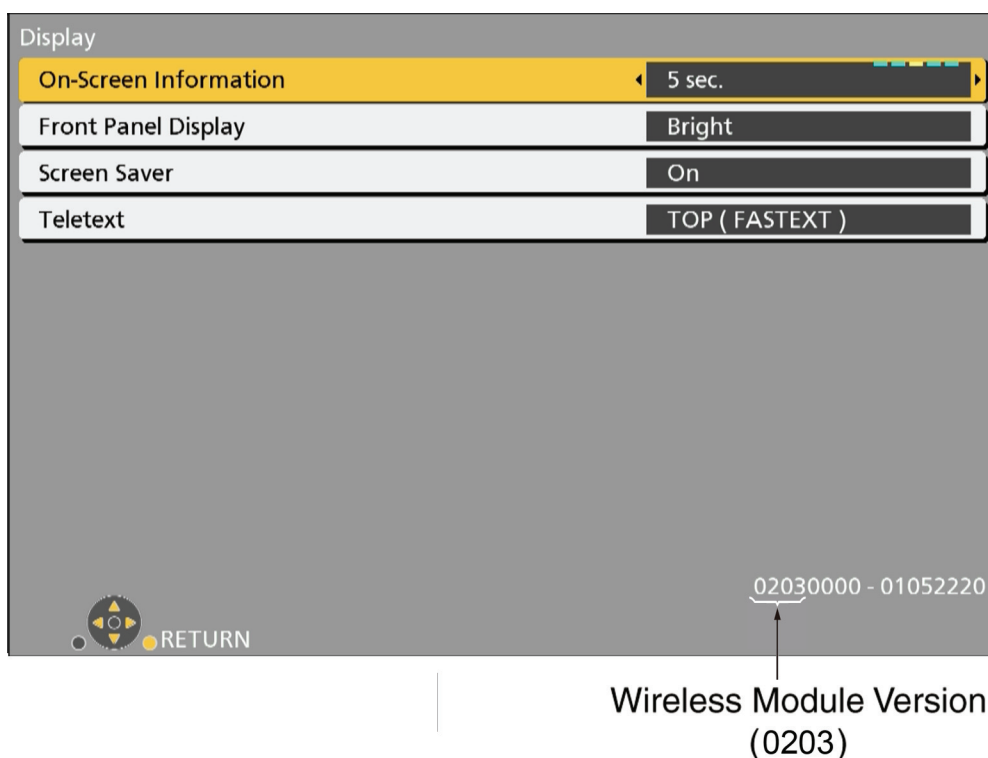

In case of Wireless LAN Module invalid.

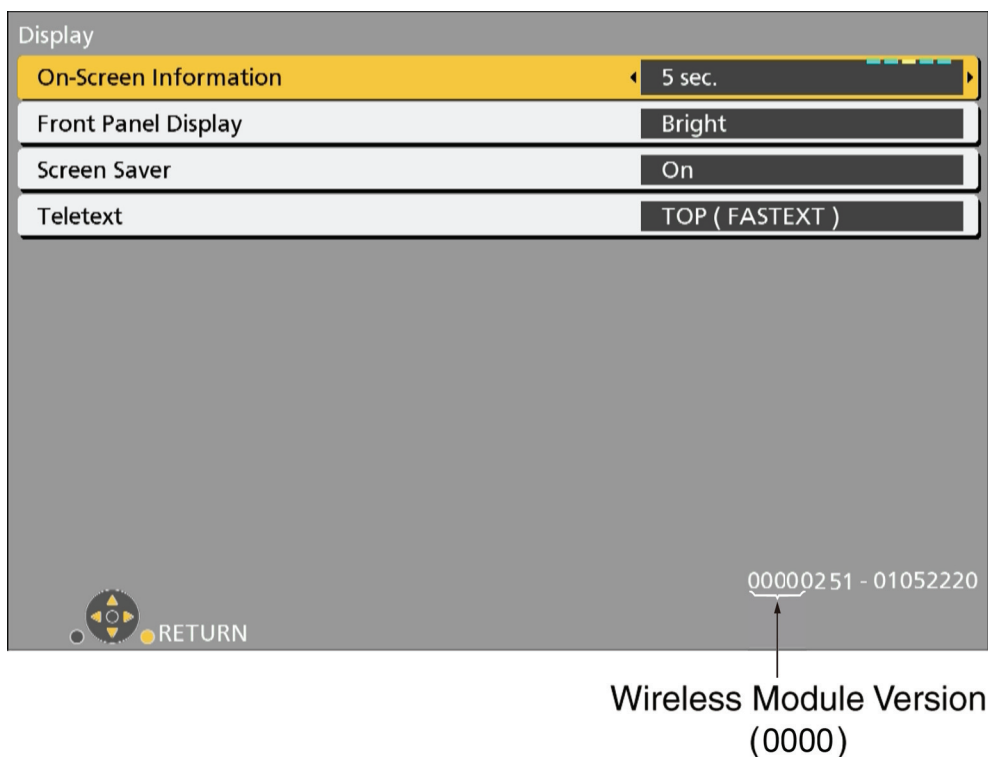

5. In case of Wireless LAN Module effective, Wireless LAN Module or Wireless LAN Module connection cable may be the source of problem.
6. Please finally check the operation of the fact.

3.9. Check with Tuner Service Mode

Inspect the inside components using the application for inspections by service personnel.

Main functions

N0	Function Name	Contents
01	Hard Test	Perform Access Test for each hard device and display the result.
02	User Setting Information Backup	Backup/ Restore User Setting Item (The Initial Setting) to the USB .
03	Time xxxxxxxx Count yyyyyyy	Length of Power ON time/ Count of power ON time

1. Execute Tuner Service Mode

- Turn the power on to receive digital broadcasting (HD broadcasting).
- Press the [5] [9] and [R] button simultaneously for five seconds, then [70 RET] is displayed on FL.
- Press the [▶] button to select until [82 TSR] is displayed on FL.
- Press the [OK] button.
- It is shown to have entered the tuner service mode.
- The command is transmitted by attached remote control.

2. Finishing Service Mode

Method 1: After turning the unit "OFF", pull out the AC cord.

Method 2: Repeat turning ON and OFF twice: P-OFF → P-ON → P-OFF → P-ON.

SRV-T00L	
Device TEST	
Backup Data to USB :	Restore Data from USB :
	Time 00000:00 Count 0000000

3.9.1. Hard Test (Device Test)

Perform Access Test for each hard device and display the result.

SRV-T00L	
Device TEST	
Backup Data to USB :	Restore Data from USB :
	Time 00000:00 Count 0000000

+-----+	
	-- Hard Test Result --
+-----+	
	<1> EEPROM [READ] (Result)
+-----+	
	<2> EEPROM [WRITE] (Result)
+-----+	
	<3> TUNER 1 (Result)
+-----+	
	<4> TUNER 2 (Result)
+-----+	
	<5> LAN (Result)
+-----+	
	<6> TUNER 3 (Result)
+-----+	
	<7> -----
+-----+	
	<8> -----
+-----+	
	<9> -----
+-----+	

<Function>

- <1> : EEPROM [READ] : Read Test (D-Audio:IC6811)
- <2> : EEPROM [WRITE] : Write Test (D-Audio:IC6811)
- <3> : TUNER 1(DVB-T Tuner):I2C_Bus Check (Digital P.C.B.(TU8201))
- <4> : TUNER 2(DVB-T Tuner):I2C_Bus Check (Digital P.C.B.(TU8201))
- <5> : LAN:Register Access Test (Digital P.C.B.: IC59001)
- <6> : TUNER 3(DVB-T Tuner):I2C_Bus Check (Digital P.C.B.(TU8201))
- <7> : (None)
- <8> : (None)
- <9> : (None)

<Display>

- <1> : EEPROM [READ] OK : Normality
 NG : EEPROM Read Error
- <2> : EEPROM [WRITE] OK : Normality
 NG : EEPROM Write Error
- <3> : TUNER 1 OK : Normality
 NG : TUNER (DVB-T Tuner) I2C_Bus. Error
- <4> : TUNER 2 OK : Normality
 NG : TUNER (DVB-T Tuner) I2C_Bus. Error
- <5> : LAN OK : Normality
 NG : LAN Register Access Error
- <6> : TUNER 3 OK : Normality
 NG : TUNER (DVB-T Tuner) I2C_Bus. Error

Note:

Hard test result does not guarantee that problems do not exist even if the result is OK.
The result is used as reference when any trouble occurs.

3.9.2. Use times and number of times of Power ON/OFF

Display accumulated time of Power ON and display number of times of Power ON/OFF.

SRV-TOOL	
Device TEST	
Backup Data to USB :	Restore Data from USB :
Time 00000:00(*1)Count 0000000(*2)	

*1 : Display accumulated time of Power ON

Display on a 15-minute basis. Example: 00123:15 → 123 hour 15 minute

*2 : Display number of times of Power ON/OFF

Example: 0000123 →123

3.9.3. User Setting Information Backup

Purpose

After the recorder is repaired, the restored setting information is not default, but the information before repaired.

Operation summary

Before starting repair, import data on memory of the unit to export the data to USB on Tuner Service Mode display.

After the repair is finished, import the data on USB to export the data to the memory on the unit by operating on Tuner Service.

Mode display again.

• Data to be backed up

- Each setting item that a user can set at "SET UP" (*1) and "DVB TUNING" (START → FUNCTION → OTHERS → SET UP, DVB TUNING, and "Program timer setting", "History information" etc.

The following data cannot be backed up.

- Program chart data
- Dedicated areas for Internet site service providers (unique information for each company), broadcast mail, two-way communication list, board, or favorite page
- Status saving systems (last channel except for VHF, UHF, drive selection status, etc.)

Note:

Of user setting information, only items selected and set on the initial Setup display can be backed up and restored.

*1: Of user setting information, except items selected and set on the initial Setup display.

Operation procedure

Preparation:

Prepare a USB to export data stored in this unit.

Create the following directory on the USB.

¥ EEPBAKUP

Boot:

1. On Tuner Service Mode display
2. There are many port models of USB, you need to make sure other USB ports don't connect USB memory and USB-HDD.
3. Insert USB memory for writing.
4. Using Remote Controller, move the cursor to user's setting information backup display position (Refer to below) on Tuner Service Mode display.
5. Press [OK].
After "Try → OK" is displayed, the data is exported to USB.
(Refer to below)

SRV-TOOL	
Device TEST	
Backup Data to USB : OK	Restore Data from USB :
Time 00000:00 Count 0000000	

When OK(***) is displayed, the data is successfully exported.

Note:

If the backup file already exists in the USB, the data is overwritten and "OK" is displayed.

6. Remove the USB from the unit.
7. Turn the unit OFF to finish Tuner Service Mode.

Restoring the back up data to the unit

1. Turn the unit ON.
Perform the following: Function MENU - Setup- Basic Settings - Others - Initialize - Shipping Condition.
2. Start Tuner Service Mode.
3. There are many port models of USB, you need to make sure other USB ports don't connect USB memory and USB-HDD.
4. Insert the USB in save data to the unit.
5. Using Remote Controller, move the cursor to user's setting information backup display position (Refer to below) on Tuner Service Mode display.

SRV-TOOL	
Device TEST	
Backup Data to USB : OK	Restore Data from USB : OK
Time 00000:00 Count 0000000	

6. Press [ENTER].
After "Try → OK" is displayed, the data is restored to USB.
(Refer to below)

SRV-TOOL	
Device TEST	
Backup Data to USB : OK	Restore Data from USB : OK (***)
Time 00000:00 Count 0000000	

When OK(***) is displayed, the data is successfully exported.

7. Remove the USB from the unit.
8. Turn the unit OFF to finish Tuner Service Mode.

3.10. Description of the Self Diagnosis <Operation Method, Details>

3.10.1. How to check the diagnosis code

This device can display the device information with a 16 digit number (Diagnosis code) on the monitor in order to promptly check the device status.

3.10.1.1. Procedure of the diagnosis code check

1. Turn power on. (E-E mode without recording or running as a server)
2. Press and hold [5], [9] and [Red] buttons on the remote control simultaneously for 5 seconds or more until front display indicates "70 RET" as shown below.



3. Press [POWER] button on the main unit or [▶] on the remote control several times until front display indicates "96 DIC".
Front display indicates as follows by pressing [POWER] or [▶] button.

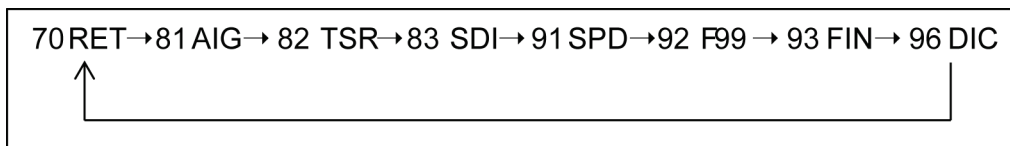

- * If front display indicates "-- --" or enter to the other mode, reset by pressing [POWER] button and repeat from first step.
4. Press [OPEN/CLOSE] button on the main unit or [OK] button on the remote control to run self diagnosis.

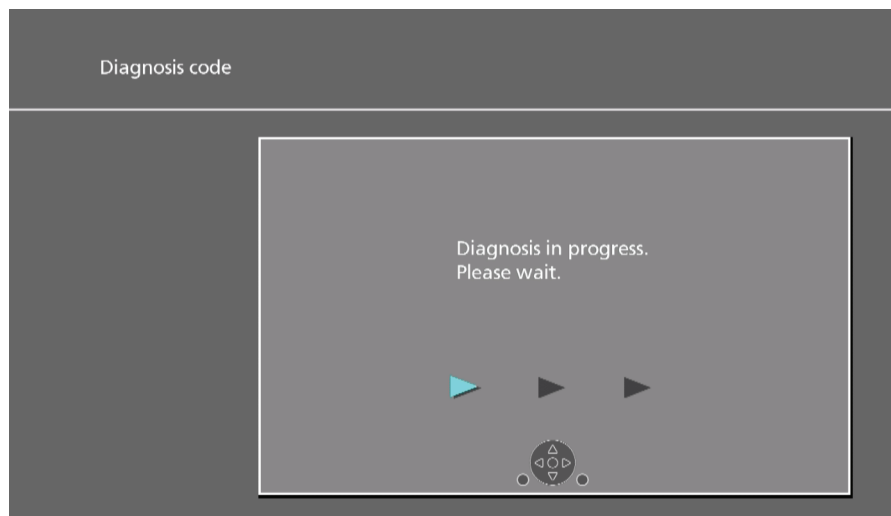

5. Press the [OK] button. The following "Diagnosis Code" will be displayed.

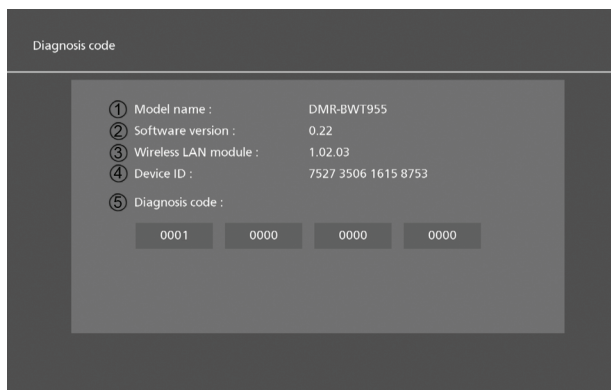

Item		Details
①	Model Name :	Display the model name.
②	Software version :	Display the software version.
③	Wireless LAN module :	Display the wireless LAN module version. (Built-in wireless LAN model)
	Wireless LAN adapter :	Display the wireless LAN module version. (Wireless LAN external model)
	(No display)	Wireless LAN unsupported model
④	Device ID :	Display the device ID.
⑤	Diagnosis code :	Display the diagnosis code.

Release from self diagnosis mode:

1. Press the [POWER] button on the main Unit.

3.10.1.2. Description of the self diagnosis code

Self diagnosis code details:

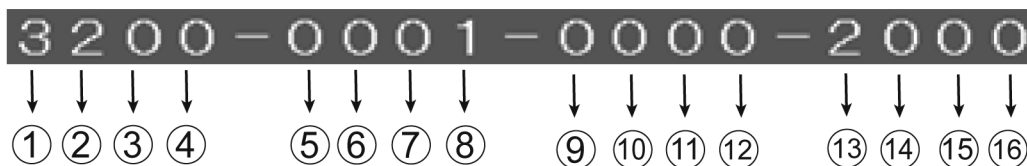

	Diagnosis details		Diagnosis details
①	Drive	⑨	Reserved ("0" displays always)
②	HDD	⑩	Reserved ("0" displays always)
③	Reserved ("0" displays always)	⑪	Reserved ("0" displays always)
④	USB-HDD diagnosis	⑫	Reserved ("0" displays always)
⑤	Digital P.C.B. (CPU/Flash/DDR/HDMI etc.)	⑬	Failure history of Drive/HDD/FAN
⑥	TUNER system	⑭	Reserved ("0" displays always)
⑦	Reserved ("0" displays always)	⑮	Reserved ("0" displays always)
⑧	Main P.C.B.(EEPROM/Ether)	⑯	Reserved ("0" displays always)

* If the power does not turn on or CPU does not work properly, self diagnosis will not run.
In that case, check the power supply or PCB connection.

[Specifications of Detailed Diagnostic Code]

1. Diagnosis of BD Drive

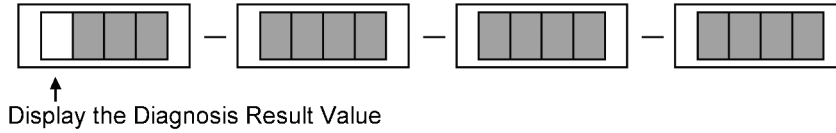

<Diagnosis Result Value>

0	There is no history of failure/ abnormality detected on the Drive. Please check other diagnosis items.
1	Unable to communicate with the Drive. Check to see if there is any problem with the connection between S-ATA cable or Drive power 6P cable and the voltage power supply. If there is no problem with the supply voltage or connection, there is a high possibility of Drive unit defect.
2	There is an error that can be determined as a failure in the Drive.
3	There is an error that is caused by disk error or disk operation. If this error occurs only in specific disk that you are using, check to see if the same malfunction occurs by changing the media to a disk of different manufacturer or different type. Check by unplugging and plugging back the FFC wire or S-ATA cable of Drive connection. Replace the wire for improvement. If the turntable is dirty, malfunction may originate from slipping phenomenon, etc. Please perform cleaning. If the disk cannot be read/written properly after cleaning, replacing the Drive may be necessary.
8	Unable to execute the Diagnosis Code Function normally. There is a possibility of malfunction in the digital P.C.B. side.
9	There is an error that can be determined as unsupported Drive. Replacing the Drive unit is necessary.
Other	The Input Code is not correct. Please check the Diagnosis Code again.

Example: BD Drive is not recognizable.

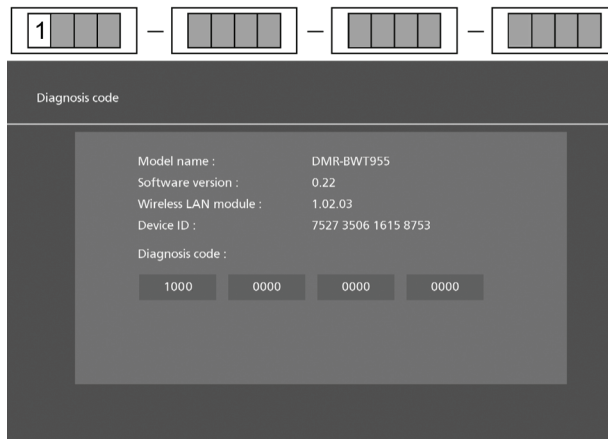

2. HDD Diagnosis

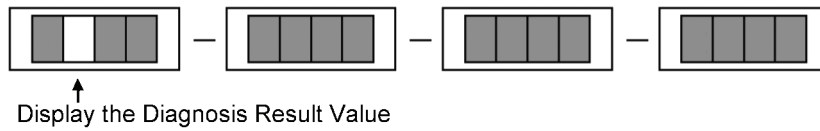

<Diagnosis Result Value>

0	No abnormality was detected from HDD inspection. Please check other diagnosis items.
1	Unable to communicate with the HDD. Check to see if there is any problem with the connection between each HDD connector and the voltage power supply. If there is no problem with the supply voltage or connection, there is a high possibility of HDD unit defect.
2	An abnormality that can be determined as HDD failure was detected. Replace the HDD unit.
8	Unable to execute the Diagnosis Code Function normally. There is a possibility of malfunction in the digital P.C.B. side.
Other	The Input Code is not correct. Please check the Diagnosis Code again.

Example: HDD is not recognizable.

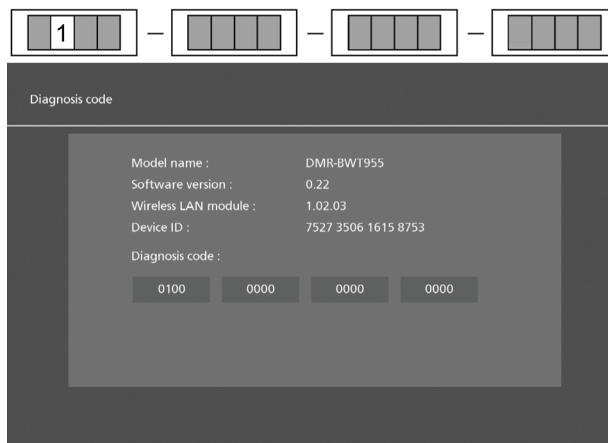

3. USB-HDD Diagnosis

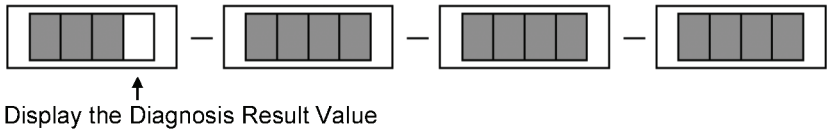

<Diagnosis Result Value>

0	No abnormality was detected from USB-HDD inspection. Please check other diagnosis items.
1	No USB-HDD is connected or some other device is connected. Check to see if there is any problem with the USB cable connection or the voltage power supply. If there is no problem with the supply voltage or connection, there is a high possibility of USB-HDD unit defect.
2	An abnormality that can be determined as USB-HDD failure was detected. Replace the USB-HDD unit.
6	If multiple USB-HDD units are connected.
7	If an unsupported USB-HDD is connected.
8	Unable to execute the Diagnosis Code Function normally. There is a possibility of malfunction in the digital P.C.B. side.
Other	The Input Code is not correct. Please check the Diagnosis Code again.

Example: USB-HDD is not recognizable.

4. Digital/Tuner/D-AUDIO P.C.B. System Diagnosis

(1) IC communication in the digital P.C.B. (CPU and Flash/DDR/HDMI, etc.)

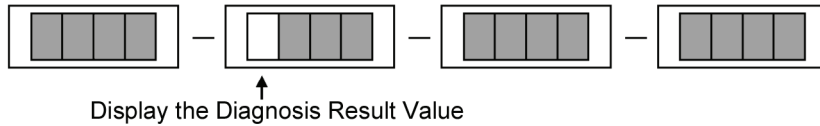

<Diagnosis Result Value>

0	No abnormality was detected in the digital P.C.B..
1	If there is a communication failure between CPU and FLASH/DDR, there is a high possibility of digital P.C.B. circuit (such as foil cutting) or parts failure.
2	If there is a communication failure between CPU and HDMI-LSI, there is a high possibility of digital P.C.B. circuit (such as foil cutting) or parts failure.
3	There is a communication failure between CPU and FLASH/DDR, and between CPU and HDMI-LSI. Take measures for "1" and "2".
4	There is an abnormality in HDMI-CEC circuit operation (High/Low Output). There is a high possibility of digital P.C.B. circuit failure (such as foil cutting) or parts failure.
5	There is a communication failure between CPU and FLASH/DDR, abnormality in HDMI-CEC circuit operation (High/Low Output). Take measures for "1" and "4".
6	There is a communication failure between CPU and HDMI-LSI, abnormality in HDMI-CEC circuit operation (High/Low Output). Take measures for "2" and "4".
7	There is a communication failure between CPU and FLASH/DDR and between CPU and HDMI-LSI, abnormality in HDMI-CEC circuit operation (High/Low Output). Take measures for "3" and "4".
Other	The Input Code is not correct. Please check the Diagnosis Code again.

(2) IC Communication of TUNER System

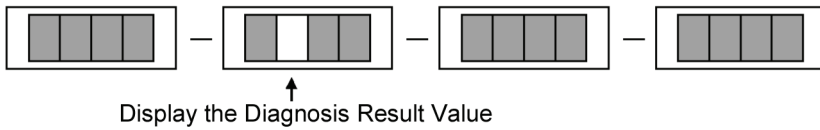

<Diagnosis Result Value>

0	No abnormality was detected in communication between the Digital Tuner and IC.
1	A communication abnormality occurred between the Digital Tuner (OFDM/Digital Modulation IC) and IC. There is a high possibility of Digital Tuner (OFDM/Digital Modulation IC) defect, or a communication failure between ICs.
2	A communication abnormality occurred between the Digital Tuner (LNB/Digital Modulation IC) and IC. There is a high possibility of Digital Tuner (LNB/Digital Modulation IC) defect, or a communication failure between ICs.
3	A communication abnormality occurred between the Digital Tuner (OFDM/Digital Modulation IC) and IC, Digital Tuner (LNB/Digital Tuner Modulation IC) and IC. There is a high possibility of Digital Tuner (OFDM/Digital Modulation IC) defect, Digital Tuner (LNB/Digital Modulation IC) defect, or a communication failure between ICs.
Other	The Input Code is not correct. Please check the Diagnosis Code again.

(3) D-AUDIO P.C.B. IC communication (e.g. B-CAS/EEPROM)

Digital P.C.B. IC communication (e.g. Ether)

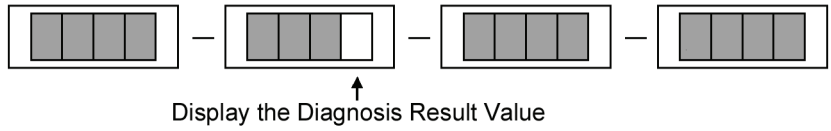

<Diagnosis Result Value>

0	No abnormality was detected.
2	An abnormality was detected in communication between the EEPROM of main P.C.B. and IC. Check the digital P.C.B. and main P.C.B. connection connector. If there is no problem, malfunction in the main P.C.B. is suspected.
4	Since a communication failure occurred between CPU and ETHER-LSI as well, there is a high possibility of digital P.C.B. circuit (such as foil cutting) or parts failure. Replace the Digital P.C.B..
6	A communication failure occurred between EEPROM of main P.C.B. and CPU, CPU and ETHER-LSI. Take measures for "2" and "4".
Other	The Input Code is not correct. Please check the Diagnosis Code again.

Example: The Ether register access error detection.

5. Failure History Analysis

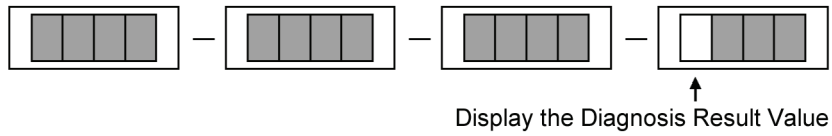

<Diagnosis Result Value>

0	There is no information for failure history.
1	If there is malfunction in Drive diagnosis items, there is a possibility that the Drive itself fails. ◦ Prioritize the Drive diagnosis results. In addition, if there is no malfunction in Drive diagnosis items, there is a possibility that the cause of malfunction is in the digital P.C.B..
2	If there is malfunction in HDD diagnosis items, there is a possibility that the HDD itself fails. ◦ Prioritize the HDD diagnosis results. In addition, if there is no malfunction in HDD diagnosis items, there is a possibility that the cause of malfunction is in the digital P.C.B.
3	There are malfunctions in Drive diagnosis items and HDD diagnosis items. Take measures for "1" and "2".
4	The fan motor may fail. Check for any snapped wire in fan motor, connector, and lead wire.
5	There is malfunction in Drive diagnosis items and the fan motor may fail. Take measures for "1" and "4".
6	There is malfunction in HDD diagnosis items and the fan motor may fail. Take measures for "2" and "4".
7	There are malfunctions in HDD diagnosis items, Drive diagnosis items and the fan motor may fail. Take measures for "3" and "4".
Other	The Input Code is not correct. Please check the Diagnosis Code again.

Example: Error occurrence of Fan Motor.

4 Specifications

Power supply: AC220 - 240V 50Hz
Power consumption: Approx. 31W
 Power consumption in standby mode
 Approx. 0.2W
 Quick Start=Off, RF OUT (Aerial Signal)=Off
Operating temperature: 5°C - 40°C
Operating humidity range: 10% - 80%RH (no condensation)

Television system

Tuner system: DVB-T
 Country: Australia
 Channel Coverage: VHF:6 -12
 UHF:27 - 69

Analog Video Input (pinjack): 1 pc
 1Vp-p (75Ω)
Analog Audio L/R Input (pinjack): 1 pc
 Full scale :2.0 Vrms at 1kHz (>10kΩ)

Analog Audio L/R Out (pinjack): 1 pc
 Full scale :2.0 Vrms at 1kHz (<1kΩ)

Digital Audio Out (optical): 1pc

Digital Audio Out (coaxial): 1pc

HDMI Out (19pin type A): 1pc

Internal HDD Capacity: 2TB

USB Port (Type A): 2 pcs

SD Card Slot: 1pc

LAN (Ethernet) Port: 1pc
 10 BASE-T/100BASE-TX

Wireless LAN:

Antenna: Tx2, Rx2
 Standard Compliance: IEEE802.11a/b/g/n
 Transmission system: OFDM system, DSSS system
 Frequency Range: 2.4 GHz / 5 GHz band
 Transfer rate (standard): IEEE802.11n: Max. 300 Mbps
 IEEE802.11g: Max. 54 Mbps
 IEEE802.11a: Max. 54 Mbps
 IEEE802.11b: Max. 11 Mbps
 * Transfer rates are theoretical values: however, actual communication rate will vary according to communication environment or connected equipment.

Access mode: Infrastructure mode
 Security: WPA™/WPA2™ (Encryption type: TKIP/AES. Authentication type:PSK) WEP(64bit / 128bit)

Recording System

BD-RE (SL/DL): Blu-ray Disc Rewritable format
 BD-R (SL/DL): Blu-ray Disc Recordable format
 DVD-RAM: DVD Video Recording format
 DVD-R (SL/DL): DVD-Video format, AVCHD format
 DVD-RW: DVD-Video format
 +R (SL/DL), +RW

Broadcast Recordings

Number of title that can be recorded

	Maximum titles
HDD	3000
BD-RE , BD-R	200
DVD-RAM, DVD-R, DVD-RW	99
+R , +RW	49

*Maximum numbers of titles is including recordings of HD CAM-CODER.

HD CAMCODER Recordings

MPEG-4 AVC/H.264 (based on AVCHD)
 Numbers of titles that can be record

	Maximum titles
HDD	3000
BD-RE , BD-R	200

*Maximum numbers of titles is including recordings of Broadcast.

Photo files

JPEG based on DCF [Design rule for Camera File system]
 MPO based on MPf [Multi Picture Format]
 Pixels: 34 x 34 ~ 8192 x 8192
 Sub Sampling: 4:2:2, 4:2:0
 Motion JPEG not supported.

Maximum numbers of contents.

	folders	files
HDD	-	20000
BD-RE, DVD-RAM, DVD-R CD-R, CD-RW, USB, SD	500	10000

Video files Audio files

Support codecs of Video: Xvid, MKV, MP4 (4k30p), MPEG (TS/PS) (*1)

Support codecs of Audio: MP3, WAV, FLAC, ACC (M4A), WMA, DSD, ALAC (*1)

*1: Supported codecs depend on media type.

Numbers of contents that can be copied to internal HDD

	Maximum numbers of folders and files
Video contents	20000
Audio contents	20000

HDMI

This unit supports "HDAVI Control 5" function.

Recording time

Recording Mode	Approx.				
	HDD (2TB)	BD-RE (SL, 25GB)	BD-RE (DL, 50GB)	BD-R (SL, 25GB)	BD-R (DL, 50GB)
DR *2 estimated bit rate (HD : 15Mbps) (SD : 8Mbps)	282 hours 529 hours	3h.20min. 6h.30min.	6h.40min. 13 hours	3h.20min. 6h.30min.	6h.40min. 13 hours
HG	315 hours	4 hours	8 hours	4 hours	8 hours
HX	471 hours	6 hours	12 hours	6 hours	12 hours
HE	707 hours	9 hours	18 hours	9 hours	18 hours
HL	946 hours	12 hours	24 hours	12 hours	24 hours
HM	1370 hours	17h.30min.	35 hours	17h.30min.	35 hours
XP	431 hours	5h.15min.	10h.30min.	5h.15min.	10h.30min.
SP	863 hours	10h.30min.	21 hours	10h.30min.	21 hours
LP	1726 hours	21 hours	42 hours	21 hours	42 hours
EP	3452 hours	42 hours	84 hours	42 hours	84 hours

Recording Mode	DVD-RAM		DVD-R DVD-RW (4.7GB)	DVD-R DL (8.5GB)	+R +RW (4.7GB)	+R DL (8.5GB)
	4.7GB	9.4GB (Double Sided)				
DR *2,HG,HX,HE,HL,HM						
XP	1 hour	2 hours	1 hour	1h.45min.	1 hour	1h.45min.
SP	2 hours	4 hours	2 hours	3h.35min.	2 hours	3h.35min.
LP	4 hours	8 hours	4 hours	7h.10min.	4 hours	7h.10min.
EP	8 hours	16 hours	8 hours	14h.20min.	8 hours	14h.20min.

*2: Recording time of DR mode may vary depending on the bit rate of broadcasting.

LASER specification

Class 1 LASER Product

Wave length: 783 nm(CDs) 661 nm(DVDs)
405 nm(BDs)

Laser power: No hazardous radiation is emitted with the safety protection

Region Code:

DVD: #4
BD: Region B

Playable discs

BD-Video: (Blu-ray 3D,BD-LIVE)
BD-ROM Version 2.4

DVD-VIDEO: DVD-Video format
CD-DA: (Audio CD)

BD-RE: Based on Ver.2.1, other files(*4)

BD-RE DL: Based on Ver.2.1, other files(*4)

BD-R: Based on Ver.1.3 and LTH type
Ver.1.3, other files(*4)

BD-R DL: Based on Ver.1.3, other files(*4)

DVD-RAM: DVD Video Recording format,
AVCHD format

DVD-R: DVD-Video format(*3), AVCHD
format(*3), other files(*5)

DVD-R DL: DVD-Video format(*3), AVCHD,
format(*3), other files(*5)

DVD-RW: DVD-Video format(*3), DVD Video
Recording format, AVCHD for-
mat(*3)

+R: DVD-Video format(*3), AVCHD
format(*3)

+R DL: DVD-Video format(*3), AVCHD
format(*3)

+RW: DVD-Video format(*3), AVCHD
format(*3)

CD-R: CD-DA, other files(*6)

CD-RW: CD-DA, other files(*6)

*3: Finalizing is necessary.

*4: BD disc that is including other file needs to be based on UDF
format.

*5: DVD disc that is including other file need to be based on UDF or
ISO9660 format.

*6: CD disc that is including other file need to be based on ISO9660
format.

SD Card

SD Memory Card (includes SDHC,SDXC card)

Format:

SD Card only FAT12,FAT16

SDHC Card only FAT32

SDXC Card only exFAT

USB device

USB 2.0 High Speed
USB mass storage device class is
supported.

Format: FAT12, FAT16, FAT32,
NTFS

Dimensions:

430mm(W) x 70mm(H) x 199mm(D) (excluding the projecting parts)

430mm(W) x 70mm(H) x 210mm(D) (including the projecting parts)

Mass:

Approx .3.0kg

Solder:

This model uses lead free
solder(PbF).

Note:

Specifications are subject to change without notice.
Useable capacity will be less.(SD Card)

5 Location of Controls and Components

Main unit

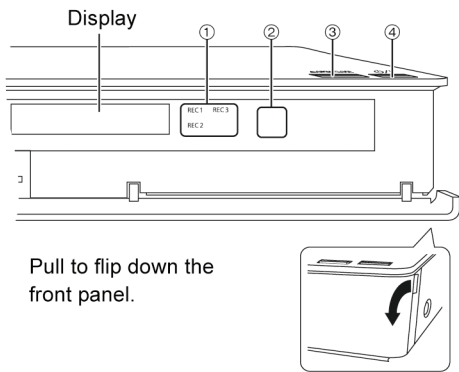

Pull to flip down the front panel.

- ① Recording indicator
 - The indicator will light up while recording.
 - The indicator will blink while recording is paused and before recording starts.
- ② Remote control signal sensor
 - Angle: Approx. 20° up and down, 30° left and right
 - Distance: Within approx. 7 m in front of the unit
- ③ Open/close disc tray
- ④ **Standby/on switch (⏻/⏻)**
 - Press to switch the unit from on to standby mode or vice versa. In standby mode, the unit is still consuming a small amount of power.



- While writing to/reading from the media, do not switch the unit to standby mode or remove the media. Such action may result in loss of the media contents.
- When inserting the media, ensure that it is facing the right way up.

Display

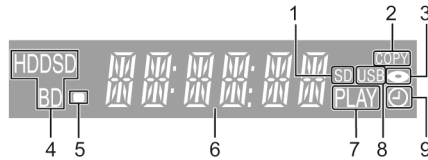

- 1 SD card slot indicator
- 2 Copying indicator
- 3 Disc indicator
- 4 Drive (HDD, BD or SD) indicator
- 5 Remote control signal indicator
- 6 Main display section indicator
 - Current time
 - Playback counter
 - Various messages
- 7 Playback indicator
- 8 USB port indicator
- 9 Timer recording indicator
 - This indicator lights up when the timer recording standby or Keyword Recording standby is activated.

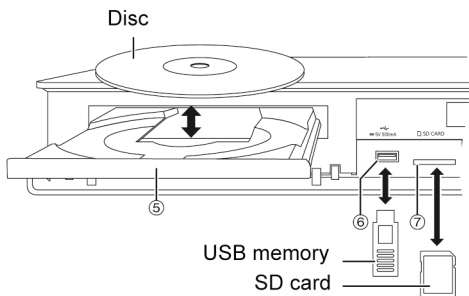

- ⑤ Disc tray
- ⑥ USB port
- ⑦ SD card slot
 - When removing the SD card, press on the centre of the card and pull it straight out.

Control reference guide

Instructions for operations are generally described using the remote control.

Remote control

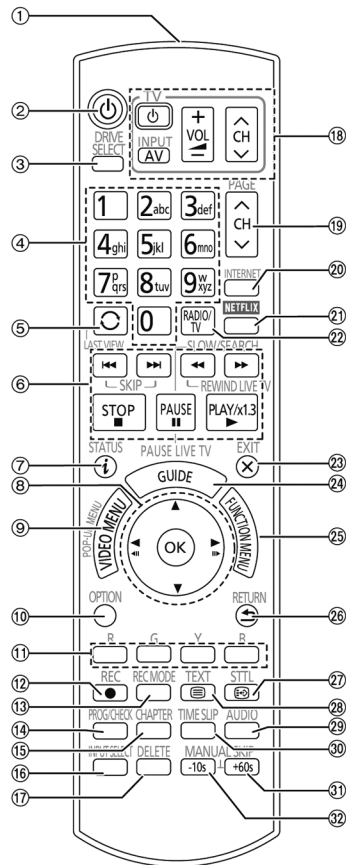

- ① Transmit the remote control signal
• Point it at remote control signal sensor on this unit.
- ② Switch the unit from on to standby mode or vice versa
- ③ Select drive (HDD, BD, SD or USB)
- ④ Select channels and title numbers, etc./Enter numbers or characters
- ⑤ Switch to the previously watched channel
- ⑥ Basic operations for recording and play, REWIND LIVE TV/PAUSE LIVE TV
- ⑦ Show Information
- ⑧ Selection/OK, Frame-by-frame

- ⑨ Show Video Menu, Top Menu, Pop-up Menu
- ⑩ Show OPTION menu
- ⑪ Colour buttons (Use in accordance with instruction on the screen.)
- ⑫ Start recording
- ⑬ Select a conversion mode/recording mode
- ⑭ Show the Timer Recording screen
- ⑮ Create chapter
- ⑯ Input select
- ⑰ To delete unwanted recorded titles, timer programmes, video or music
- ⑱ TV operation buttons
- ⑲ Channel select/Change pages in the Video Menu screen etc.
- ⑳ Show the Network Service screen
- ㉑ Show NETFLIX screen
- ㉒ Switching to the radio channel list
- ㉓ Exit the menu screen
- ㉔ Show the TV Guide screen
- ㉕ Show the FUNCTION MENU screen
- ㉖ Return to previous screen
- ㉗ Show subtitles
- ㉘ Show Teletext
- ㉙ Select audio
- ㉚ Skip the specified time
- ㉛ Skip approx. 1 minute forward
- ㉜ Skip approx. 10 seconds backward

Insert batteries

Insert so the poles (+ and -) match those in the remote control.

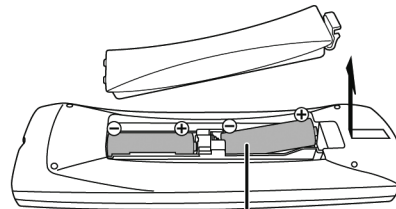

R6/LR6, AA
(Alkaline or manganese batteries)

6 Installation Instructions

6.1. Taking out the Disc from BD-Drive Unit when the Disc cannot be ejected by [OPEN/CLOSE] button

6.1.1. Forcible Disc Eject

6.1.1.1. When the power can be turned off.

1. Turn off the power, press and hold [OK], [B] and [Y] on the remote control at the same time for more than 5 seconds. "00 RET" is displayed on the unit's display.
2. Repeatedly press [▶] on the remote control or [POWER] on the unit until "06 FTO" is displayed on the unit's display.
3. Press [OK] on the remote control or [OPEN/CLOSE] on the unit.

6.1.1.2. When the power can not be turned off.

1. Press [POWER] key on the front panel for over 4 seconds to turn off the power forcibly, press and hold [OK], [B] and [Y] on the remote control at the same time for more than 5 seconds. "00 RET" is displayed on the unit's display.
2. Repeatedly press [▶] on the remote control or [POWER] on the unit until "06 FTO" is displayed on the unit's display.
3. Press [OK] on the remote control or [OPEN/CLOSE] on the unit.

6.1.2. When the Forcible Disc Eject can not be done.

1. Turn off the power and pull out AC cord.
2. Put deck so that bottom can be seen.
3. Slide SLIDE CAM by Paper Clip or minus screw driver (small) in the direction of arrow to eject tray slightly.

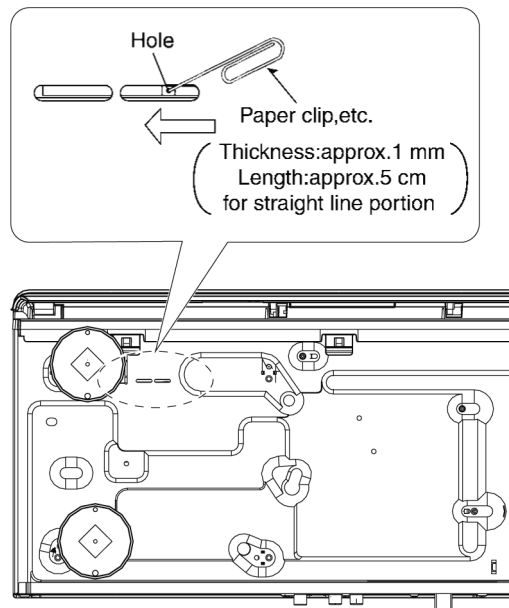

4. Put deck upward, and pick out Tray by finger.

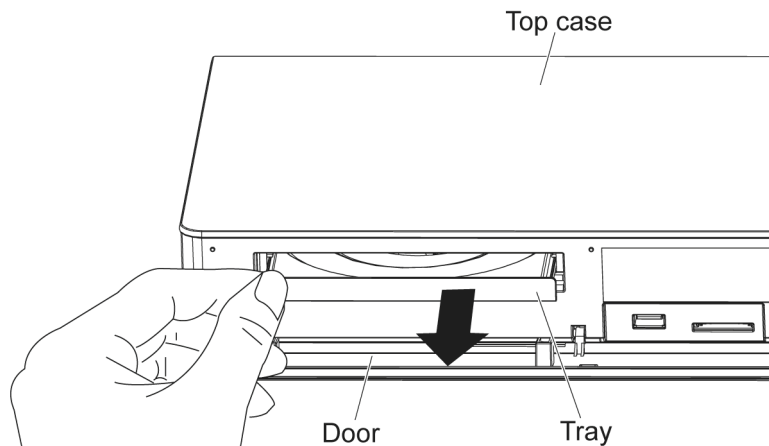

7 Service Mode

7.1. Self-Diagnosis and Special Mode Setting

7.1.1. Self-Diagnosis Functions

Self-Diagnosis Function provides information for errors to service personnel by “Self-Diagnosis Display” when any error has occurred.

U**, **H**** and **F**** are stored in memory and held.

You can check latest error code by transmitting [0] [1] of Remote Controller in Service Mode.

Automatic Display on FL will be cancelled when the power is turned off or AC input is turned off during self-diagnosis display is ON.

Error Code	Diagnosis Contents	Description	Monitor Display	Automatic FL display
U30	Remote control code error	Display appears when main unit and remote controller codes are not matched.	No display	<div style="border: 1px solid black; padding: 5px; text-align: center;">BD *</div> <p>“*” is remote controller code of the main unit. Display for 5 seconds.</p>
U59	Abnormal inner temperature detected	Display appears when internal temperature of deck reaches limit temperature. The power is turned off forcibly. For 30 minutes after this, all key entries are disabled. (Fan motor operates at the highest speed for the first 5 minutes. For the remaining 25 minutes, fan motor is also stopped.) The event is saved in memory as well.	No display	<div style="border: 1px solid black; padding: 5px; text-align: center;">U59</div> <p>“U59” is displayed for 30 minutes.</p>
U61	The unit is carrying out its recovery process. (with no disc in the disc tray)	<ul style="list-style-type: none"> The unit detected an error while recording or playing with no disc in the disc tray. The unit is carrying out its recovery process. This process restores the unit to normal operation. The unit is not broken. Wait until the message disappears.	No display	<div style="border: 1px solid black; padding: 5px; text-align: center;">U61</div>
U71	HDMI incompatible error (HDCP incompatible)	Display this error when the equipment (compatible with DVI such as TV, amplifier etc.) connected to the unit by HDMI is incompatible with HDCP. *HDCP=High-bandwidth Digital Content Protection	No display	<div style="border: 1px solid black; padding: 5px; text-align: center;">U71</div>
U72	HDMI connection error (Communication error)	This error is displayed when there are any communication problems with the unit and the equipments (TV, amplifier etc.) connected to the unit by HDMI. (or when there is a problem with the HDMI cable)	No display	<div style="border: 1px solid black; padding: 5px; text-align: center;">U72</div> <p>U72 display disappears when error has been solved by Power OFF/ON of connecting equipment or by inserting/removing of HDMI cable.</p>
U73	HDMI connection error (authentication error)	When authentication error occurs while the equipments (TV, amplifier etc.) are connected by HDMI. (or when there is a problem with the HDMI cable)	No display	<div style="border: 1px solid black; padding: 5px; text-align: center;">U73</div> <p>U73 display disappears when error has been solved by Power OFF/ON of connecting equipment or by inserting/removing of HDMI cable.</p>
U76	HDMI connection error	HDMI cannot be output because you are connected to a model that does not support copyright protection.	No display	<div style="border: 1px solid black; padding: 5px; text-align: center;">U76</div>
U77	Illegal disc error	Due to the current disc not having authorized copyright information, video output is not performed.	No display	<div style="border: 1px solid black; padding: 5px; text-align: center;">U77</div>

Error Code	Diagnosis Contents	Description	Monitor Display	Automatic FL display
U88	The unit is carrying out its recovery process. (with a disc in the disc tray)	• The unit detected an error while recording or playing with a disc in the disc tray. The unit is carrying out its recovery process. This process restores the unit to normal operation. The unit is not broken. Wait until the message disappears.	No display	U88
U99	Hang-up	Displayed when communication error has occurred between Main microprocessor and Timer microprocessor.	No display	U99 Displayed is left until the [POWER] key is pressed.
H19 02	Inoperative fan motor	When inoperative fan motor is detected after powered on, the power is turned off automatically. The event is saved in memory.	No display	No display
F00	No error information	Initial setting for error code in memory (Error code Initialization is possible with error code initialization and main unit initialization.)	No display	F00
F34	Initialization error when main microprocessor is started up for program recording	When initialization error is detected after starting up main microprocessor for program recording, the power is turned off automatically. The event is saved in memory.	No display	No display
F58	Drive hardware error	When Drive unit error is detected, the event is saved in memory.	No display	No display
F74	HDMI Device Key Communication error	HDMI connection could not be authenticated due to a transfer malfunction. Factor of HDMI Device key-road failure • When HDMI LSI is damaged. • When the bus line of I2C doesn't operate normally. • When device key information recorded is damaged.	No display	F74
F75	HDMI Device Key Information error	HDMI connection could not be authenticated due to an internal data malfunction. Factor of HDMI Device key-road failure • When HDMI LSI is damaged. • When the bus line of I2C doesn't operate normally. • When device key information recorded is damaged.	No display	F75
BD *	Remote control code error	Display appears when main unit and remote controller codes are not matched.	No display	BD * *** is remote controller code of the main unit. Display for 5 seconds.
UNSUPPORT	Unsupported disc error	*An unsupported format disc was played, although the drive starts normally. *The data format is not supported, although the media type is supported. *Exceptionally in case of the disc is dirty.	"This disc is incompatible."	Displayed for 5 seconds. UNSUPPORT The character indication flows sideways.
NO READ	Disc read error	*A disc is flawed or dirty. *A poor quality failed to start. *The track information could not be read.	"Cannot read. Please check the disc."	NOREAD The character indication flows sideways.
HARD ERR	Drive error	The Drive detected a hard error.	"BD Drive error."	Display for 5 seconds. HARD ERR The character indication flows sideways.
SELF CHECK	Restoration operation	Since the power cord fell out during a power failure or operation, it is under restoration operation. *It will OK, if a display disappears automatically. If a display does not disappear, there is the possibility that defective Digital P.C.B. / BD Drive.	No display	SELF CHECK The character indication flows sideways.

Error Code	Diagnosis Contents	Description	Monitor Display	Automatic FL display
PLEASE WAIT	Unit is in termination process	Unit is in termination process now. "BYE" is displayed and power will be turned off. In case "Quick Start" of setup menu is ON, it is displayed in restoration operation for AC off.	No display	PLEASE WAIT The character indication flows sideways.
UNFORM-AT	Unformatted disc error	You have inserted an unformatted BD-RE, BD-R, DVD-RAM or DVD-RW that is unformatted or recorded on other equipment.	Format This disc is not formatted properly. Format the disc in DISK MANAGEMENT?	UNFOR MAT The character indication flows sideways.
IR ERR	IR communication error	[IR ERR] is displayed when communication between Timer microprocessor and IR microprocessor fails.	No display	IR ERR
No REC	Recording is impossible	[No REC] is displayed when recording is impossible due to the defect, dirt or wound of media.	No display	NoREC
HDD ERROR	[HDD ERR] is displayed when start up of HDD was failed. (Except error of setting of Power on Stand-by)	a) When normal start up was failed. b) When start up at HDD boot was failed. c) When start up from state of P-OFF was failed. d) When start up from state of HDD SLEEP was failed. [HDD ERR] is displayed when above each start up of HDD was failed. *In case b), tray opens automatically and [HDDERR] is displayed until version up disc is inserted.	No display	HDDERR
HDD NG	Power on Stand-by setting error	[HDD NG] is displayed when power on Stand-by setting of HDD is NG or when HDD which power on Stand-by is not set to is used. Please try to replace HDD with genuine HDD as service parts.	No display	HDD NG
NoERAS	Erase is impossible	You cannot delete items on this disc. The disc may be damaged. Use a new disc.	No display	NoERAS
NoWRIT	Writing is impossible	You cannot write to this disc. The disc may be damaged. Use a new disc.	No display	NoWRIT
PROG FULL	Timer programmes are full	There are already 32 timer programmes. Delete unnecessary timer programmes.	No display	PROG FULL

7.1.2. Special Modes Setting

* The command is transmitted by attached remoSte control.

Item		FL Display	Key Operation
Mode Name	Description		
Rating password	The audiovisual level setting password is initialized to "Level 8".	① 00 RET ② 03 VL ③ INIT	① While the unit is on, disc is not in tray, press and hold [OK], [B] and [Y] on the remote control at the same time for more than 5 seconds. -"00 RET" is displayed on the unit's display. ② Repeatedly press [▶] on the remote control or [POWER] on the unit until. "03 VL" is displayed on the unit's display. ③ Press [OK] on the remote control or [OPEN/CLOSE] on the unit.
Service Mode	Setting every kind of modes for servicing. *Details are described in "7.1.3. Service-Mode at a glance".	② 70 RET ③ 80 SRV ④ HELLO--SERV	① While the power is off, press and hold [5], [9] and [R] on the remote control at the same time for more than 5 seconds. -"70 RET" is displayed on the unit's display. ② Repeatedly press [▶] on the remote control or [POWER] on the unit until "80 SRV" is displayed on the unit's display. ③ Press [OK] on the remote control or [OPEN/CLOSE] on the unit.
BD-ROM history cleaning	< Persistent Storage> of BD-ROM standard is cleaned. Screen display: [The history has been cleared.] is displayed for five seconds.	① 50 RET ② 51 NOP ③ 52 BRE	① While the unit is on, disc is not in tray, press and hold [6], [7] and [Y] on the remote control at the same time for more than 5 seconds. -"50 RET" is displayed on the unit's display. ② Repeatedly press [▶] on the remote control or [POWER] on the unit until "51 NOP" is displayed on the unit's display.. ③ Press and hold [STOP] on the remote control until "52 BRE" is displayed on the unit's display. ④ Press [OK] on the remote control or [OPEN/CLOSE] on the unit.
Forced disc eject	Removing a disc that cannot be ejected. The tray will open and unit will shift to P-off mode. While Demonstration Lock is being set, this Forced disc eject function is not accepted.	① 00 RET ② 06 FTO	① While the power is off, press and hold [OK], [B] and [Y] on the remote control at the same time for more than 5 seconds. -"00 RET" is displayed on the unit's display. ② Repeatedly press [▶] on the remote control or [POWER] on the unit until "06 FTO" is displayed on the unit's display. ③ Press [OK] on the remote control or [OPEN/CLOSE] on the unit.
Forced power-off	When the power button is not effective while power is ON, turn off the power forcibly. *When Timer REC is ON or EXT-LINK is ON, execute "Forced Power-off" after releasing Timer REC or EXT-LINK.	Display in P-off mode.	Press [POWER] key over than 10 seconds.

Item		FL Display	Key Operation
Mode Name	Description		
Demonstration lock/unlock	Ejection of the disc is prohibited. The lock setting is effective until unlocking the tray and not released by Main unit initialization of service mode.	*When lock the tray. ① 00 RET ② 04 PRG ③ 10 OCL ④ LOCK "LOCK" is displayed for 3 seconds.	① While the unit is on, disc is in tray, press and hold [OK], [B] and [Y] on the remote control at the same time for more than 5 seconds. - "00 RET" is displayed on the unit's display. ② Repeatedly press [▶] on the remote control or [POWER] on the unit until "04 PRG" is displayed on the unit's display. ③ Press and hold [STOP] on the remote control until "10 OCL" is displayed on the unit's display. ④ Press [OK] on the remote control or [OPEN/CLOSE] on the unit.
		*When unlock the tray. ① 00 RET ② 04 PRG ③ 10 OCL ④ UNLOCK "UNLOCK" is displayed for 3 seconds.	① While the unit is on, disc is in tray, press and hold [OK], [B] and [Y] on the remote control at the same time for more than 5 seconds. - "00 RET" is displayed on the unit's display. ② Repeatedly press [▶] on the remote control or [POWER] on the unit until "04 PRG" is displayed on the unit's display. ③ Press and hold [STOP] on the remote control until "10 OCL" is displayed on the unit's display. ④ Press [OK] on the remote control or [OPEN/CLOSE] on the unit.
		*When press [OPEN/CLOSE] key while the tray being locked. LOCK Display "LOCK" for 3 seconds.	Press [OPEN/CLOSE] key while the tray is being locked.
Progressive initialization	The progressive setting is initialized to Interface.	① 00 RET ② 04 PRG	① While the unit is on, press and hold [OK], [B] and [Y] on the remote control at the same time for more than 5 seconds. - "00 RET" is displayed on the unit's display. ② Repeatedly press [▶] on the remote control or [POWER] on the unit until "04 PRG" is displayed on the unit's display. ③ Press and hold [OK] on the remote control or [OPEN/CLOSE] on the unit for at least 3 seconds.
Switch the TV system	Switch the TV system to another one.	① 00 RET ② 05 P/N	① While the unit is on, press and hold [OK], [B] and [Y] on the remote control at the same time for more than 5 seconds. - "00 RET" is displayed on the unit's display. ② Repeatedly press [▶] on the remote control or [POWER] on the unit until "05 P/N" is displayed on the unit's display. ③ Press and hold [OK] on the remote control or [OPEN/CLOSE] on the unit for at least 3 seconds.

Item		FL Display	Key Operation
Mode Name	Description		
Deep Colour Initialization	The Deep Colour setting is initialized.	① 00 RET ② 07 DC	① While the unit is on, press and hold [OK], [B] and [Y] on the remote control at the same time for more than 5 seconds. -"00 RET" is displayed on the unit's display. ② Repeatedly press [▶] on the remote control or [POWER] on the unit until "07 DC" is displayed on the unit's display. ③ Press and hold [OK] on the remote control or [OPEN/CLOSE] on the unit for at least 3 seconds.
CS reset	Reset the information about the following Service Mode. <ul style="list-style-type: none"> • Error History • BD Drive Last Error • Error Code • HDD Spin-up time • Laser Used Time 	① 70 RET ② 93 FIN ③ FACT	① While the unit is on, press and hold [5], [9] and [R] on the remote control at the same time for more than 5 seconds. -"70 RET" is displayed on the unit's display. ② Repeatedly press [▶] on the remote control or [POWER] on the unit until "93 FIN" is displayed on the unit's display. ③ Press [OK] on the remote control or [OPEN/CLOSE] on the unit for at least 3 seconds.
Diagnosis Code display	Display the Diagnosis Code	① 70 RET ② 96 DIC ③ Diagnosis in progress. Please Wait	① While the unit is on, press and hold [5], [9] and [R] on the remote control at the same time for more than 5 seconds. -"70 RET" is displayed on the unit's display. ② Repeatedly press [▶] on the remote control or [POWER] on the unit until "96 DIC" is displayed on the unit's display. ③ Press [OK] on the remote control or [OPEN/CLOSE] on the unit.

7.1.3. Service Modes at a glance

Information necessary for service can be displayed.

Service mode setting:

1. Turn the power off.
2. Press the [5] [9] and [R] button simultaneously for five seconds, then [70 RET] is displayed on FL.
3. Press the [▶] button to select until [80 SRV] is displayed on FL.
4. Press the [OK] button.
5. It is displayed on FL as [HELLO-->SERV].: It is shown to have entered the service mode.
6. The command is transmitted by attached remote control.





Method of making clear service mode: Press the power button (power off).

The display of information to each command is as follows.

NOTE:

Do not use it excluding the designated command.

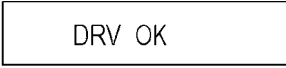
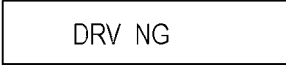
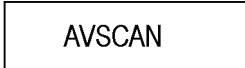
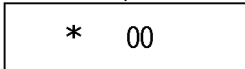
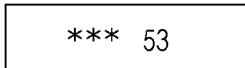
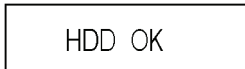
Item		FL Display	Key Operation
Mode Name	Description		(Remote controller key)
Release Items	Item of Service Mode executing is cancelled.	<div style="border: 1px solid black; padding: 5px; width: fit-content; margin: 0 auto;">SERV</div>	Press [0] [0] in service mode.
Error Code Display	Last Error Code of U/H/F held by Timer is displayed on FL. *Details are described in "7.1.1. Self-Diagnosis Functions".	<div style="border: 1px solid black; padding: 5px; width: fit-content; margin: 0 auto;">♣ □ □</div> <p>* ♣ shows U/H/F. □ □ shows number.</p> <p>If any error history does not exist, [F00] is displayed.</p>	Press [0] [1] in service mode
ROM Version Display	The display contents are switched over every 5 seconds. 1. Region code 2. Main firm version 3. Timer firm version 4. Drive firm version 5. ROM correction version 6. BOO2 version 7. BOO3 version 8. CDDB version 9. Voice version	<p>1. <div style="border: 1px solid black; padding: 5px; width: fit-content; margin: 0 auto;">NO_ \$%</div></p> <p>\$: Region of DVD (Example: 1,2.....) %: Region of BD (Example: A,B.....)</p> <p>2. <div style="border: 1px solid black; padding: 5px; width: fit-content; margin: 0 auto;">****</div></p> <p>3. <div style="border: 1px solid black; padding: 5px; width: fit-content; margin: 0 auto;">##O****</div></p> <p>##: Timer firm version O: OEM ***: Product number of microcomputer</p> <p>4. <div style="border: 1px solid black; padding: 5px; width: fit-content; margin: 0 auto;">****</div></p> <p>****: Drive version</p> <p>5. <div style="border: 1px solid black; padding: 5px; width: fit-content; margin: 0 auto;">***</div></p> <p>6. <div style="border: 1px solid black; padding: 5px; width: fit-content; margin: 0 auto;">***</div></p> <p>7. <div style="border: 1px solid black; padding: 5px; width: fit-content; margin: 0 auto;">***</div></p>	Press [0] [2] in service mode

Item		FL Display	Key Operation
Mode Name	Description		(Remote controller key)
		8.  9. 	
Drive application check	Checking whether the drive is applicable drive or not.	When the drive is applicable drive.  When the drive is not applicable drive. 	Press [0] [3] in service mode.
HDD READ SEEK Inspection	Inspecting seek time of HDD to inspect performance .	At start  ↓  ↓ The [*] sign is added every approx.10 seconds while inspecting. Two digits on the right side are the progress level of the inspection (The unit is %). Example on the way of inspection:  When HDD is OK after inspection:  (NG is displayed when error is excluding 0) (Transfer rate is calculated from the AV scanning result, and when it is less than 35Mbps, NG is displayed.)  \$: [X] is displayed when seek time is over 270msec., there is error or transfer rate is NG. Position at \$ is space when excluding those. ##: Number of data of over 100msec. and less than 270msec. When it is over 100, [99] is displayed. When the number is less than 5, we judge it normal.	Press [3] [1] in service mode. * When canceling the inspection mode while executing, do "forced power-off". Method: Press [POWER] key on the main unit more than 4 seconds.

Item		FL Display	Key Operation (Remote controller key)
Mode Name	Description		
HDD READ VERIFY Inspection	Measure of access time in READ VERIFY MODE of HDD.	<p>At start</p> <div style="text-align: center;"> <div style="border: 1px solid black; padding: 5px; width: fit-content; margin: 0 auto;">AVSCAN</div> <p>↓</p> <div style="border: 1px solid black; padding: 5px; width: fit-content; margin: 0 auto;">* 00</div> <p>↓</p> </div> <p>The [*] sign is added every approx 10 seconds while inspecting. Two digits on the right side are the progress level of the inspection (The unit is %). Example on the way of inspection:</p> <div style="text-align: center;"> <div style="border: 1px solid black; padding: 5px; width: fit-content; margin: 0 auto;">*** 53</div> </div> <p>When HDD is OK after inspection:</p> <div style="text-align: center;"> <div style="border: 1px solid black; padding: 5px; width: fit-content; margin: 0 auto;">HDD OK</div> </div> <p>(NG is displayed when error is excluding 0) (Transfer rate is calculated from the AV scanning result, and when it is less than 35Mbps, NG is displayed.)</p> <div style="text-align: center;"> <div style="border: 1px solid black; padding: 5px; width: fit-content; margin: 0 auto;">HDD \$##</div> </div> <p>\$: [X] is displayed when seek time is over 270msec., there is error or transfer rate is NG. Position at \$ is space when excluding those. ##: Number of data of over 100msec. and less than 270msec. When it is over 100, [99] is displayed. When the number is less than 5, we judge it normal.</p>	<p>Press [3] [2] in service mode. * When canceling the inspection mode while executing, do "forced power-off". Method: Press [POWER] key on the main unit more than 4 seconds.</p>
HDD Spin-up time	The accumulation value of the Spin-up time of HDD is displayed.	<div style="text-align: center;"> <div style="border: 1px solid black; padding: 5px; width: fit-content; margin: 0 auto;">*****</div> </div> <p>Spin-up time of HDD is displayed. (The unit of display is hour.)</p>	<p>Press [3] [3] in service mode.</p>

Item		FL Display	Key Operation (Remote controller key)
Mode Name	Description		
HDD Standard Speed Scan	Standard speed AV scan check of HDD	<div style="text-align: center;"> <div style="border: 1px solid black; padding: 5px; width: fit-content; margin: 0 auto;">AVSCAN</div> <p style="text-align: center;">↓</p> <div style="border: 1px solid black; padding: 5px; width: fit-content; margin: 0 auto;">STEP 01</div> <p style="text-align: center;">↓</p> <div style="border: 1px solid black; padding: 5px; width: fit-content; margin: 0 auto;">STEP 10</div> <p style="text-align: center;">↓</p> <div style="border: 1px solid black; padding: 5px; width: fit-content; margin: 0 auto;">* 00</div> <p style="text-align: center;">↓</p> </div> <p>The [*] sign is added every 10 seconds while inspecting. Two digits on the right side are the progress level of the inspection (The unit is %). Example on the way of inspection:</p> <div style="text-align: center; border: 1px solid black; padding: 5px; width: fit-content; margin: 0 auto;">*** 53</div> <p>When HDD is OK after inspection:</p> <div style="text-align: center; border: 1px solid black; padding: 5px; width: fit-content; margin: 0 auto;">HDD OK</div> <p>When HDD is NG after inspection:</p> <div style="text-align: center; border: 1px solid black; padding: 5px; width: fit-content; margin: 0 auto;">HDD ***</div> <p>[*] is the number of data of NG.</p>	Press[3] [6]in service mode. * When canceling the inspection mode while executing, do "forced power-off". Method: Press [POWER] key on the main unit more than 4 seconds.
HDD Check	Simple quality judgment of HDD	<div style="text-align: center;"> <div style="border: 1px solid black; padding: 5px; width: fit-content; margin: 0 auto;">HDDCHK</div> <p style="text-align: center;">↓</p> </div> <p>When HDD is OK:</p> <div style="text-align: center; border: 1px solid black; padding: 5px; width: fit-content; margin: 0 auto;">HDD OK</div> <p>When HDD is NG:</p> <div style="text-align: center; border: 1px solid black; padding: 5px; width: fit-content; margin: 0 auto;">HDD NG</div>	Press [3] [7] in service mode.

Item		FL Display	Key Operation (Remote controller key)
Mode Name	Description		
HDD/BD Drive Simple Check	Check if HDD Self-Diagnosis test was performed or Drive last error occurred within 4 weeks. * If the current date or the date when the error occurred is wrong, correct judgement may not be made.	<p>HDD Self-Diagnosis test start.</p> <div style="border: 1px solid black; padding: 5px; width: fit-content; margin: 5px auto;">HDDCHK</div> <p>When HDD Self-Diagnosis test result is OK.</p> <div style="border: 1px solid black; padding: 5px; width: fit-content; margin: 5px auto;">HDD OK</div> <p>When HDD Self-Diagnosis test result is NG.</p> <div style="border: 1px solid black; padding: 5px; width: fit-content; margin: 5px auto;">HDD NG</div> <p>When the drive malfunction was detected within 4 weeks ago.</p> <div style="border: 1px solid black; padding: 5px; width: fit-content; margin: 5px auto;">DRV NG</div> <p>When the drive malfunction was detected more than 4 weeks ago or Drive last error data does not exist.</p> <div style="border: 1px solid black; padding: 5px; width: fit-content; margin: 5px auto;">DRV OK</div> <p>[HDD OK] from [DRV OK] are repeatedly displayed in turn.</p>	Press [3][8] in service mode.
Laser Used Time Indication	Check laser used time (hours) of drive.	<p>Laser used time: BD Playback</p> <div style="border: 1px solid black; padding: 5px; width: fit-content; margin: 5px auto;">BP*****</div> <p>Laser used time: BD Recording</p> <div style="border: 1px solid black; padding: 5px; width: fit-content; margin: 5px auto;">BR*****</div> <p>Laser used time: DVD Playback</p> <div style="border: 1px solid black; padding: 5px; width: fit-content; margin: 5px auto;">DP*****</div> <p>Laser used time: DVD Recording</p> <div style="border: 1px solid black; padding: 5px; width: fit-content; margin: 5px auto;">DR*****</div> <p>Laser used time: CD Playback</p> <div style="border: 1px solid black; padding: 5px; width: fit-content; margin: 5px auto;">CD*****</div> <p>Display those repeatedly.</p> <ul style="list-style-type: none"> ●(*****) is the used time display in hour. ● Laser used time of BD/DVD/CD in Playback/Recording mode is counted. 	Press [4] [1] in service mode.

Item		FL Display	Key Operation (Remote controller key)
Mode Name	Description		
BD Drive Last Error	BD Drive error code display. * For details about the drive error code, refer to the Service Manual for the specific BD Drive.	<p>1. Error Number is displayed for 5 seconds.</p> <div style="border: 1px solid black; padding: 5px; width: fit-content; margin: 5px auto;">NO **</div> <p>2. Time when the error has occurred is display for 5 seconds.</p> <div style="border: 1px solid black; padding: 5px; width: fit-content; margin: 5px auto;">YYMMDD</div> <p>YY: Year MM: Month DD: Day</p> <p>3. Last drive error (1/2) is displayed for 5 seconds.</p> <div style="border: 1px solid black; padding: 5px; width: fit-content; margin: 5px auto;">*****</div> <p>00 : Bad disc 03 : Bad disc 04 : Bad disc or drive malfunction</p> <p>4. Last drive error (2/2) is displayed for five seconds.</p> <div style="border: 1px solid black; padding: 5px; width: fit-content; margin: 5px auto;">*****</div> <p>5. Error occurring disc type is displayed for 5 seconds.</p> <p>DVD ROM</p> <div style="border: 1px solid black; padding: 5px; width: fit-content; margin: 5px auto;">DVD</div> <p>CD</p> <div style="border: 1px solid black; padding: 5px; width: fit-content; margin: 5px auto;">CD</div> <p>DVD-RAM (2.6GB)</p> <div style="border: 1px solid black; padding: 5px; width: fit-content; margin: 5px auto;">RAM26</div> <p>DVD-RAM (4.7GB)</p> <div style="border: 1px solid black; padding: 5px; width: fit-content; margin: 5px auto;">RAM47</div> <p>DVD-R</p> <div style="border: 1px solid black; padding: 5px; width: fit-content; margin: 5px auto;">DVDR</div> <p>DVD-RW</p> <div style="border: 1px solid black; padding: 5px; width: fit-content; margin: 5px auto;">DVDRW</div> <p>CD-R</p> <div style="border: 1px solid black; padding: 5px; width: fit-content; margin: 5px auto;">CDR</div>	Press [4] [2] in service mode.

Item		FL Display	Key Operation (Remote controller key)
Mode Name	Description		
		CD-RW <div style="border: 1px solid black; padding: 5px; width: fit-content; margin: 5px auto;">CDRW</div>	
		DVD+R <div style="border: 1px solid black; padding: 5px; width: fit-content; margin: 5px auto;">DVDPR</div>	
		DVD+RW <div style="border: 1px solid black; padding: 5px; width: fit-content; margin: 5px auto;">DVDPRW</div>	
		BD-ROM <div style="border: 1px solid black; padding: 5px; width: fit-content; margin: 5px auto;">BDROM</div>	
		BD-RE <div style="border: 1px solid black; padding: 5px; width: fit-content; margin: 5px auto;">BDRE</div>	
		BD-R <div style="border: 1px solid black; padding: 5px; width: fit-content; margin: 5px auto;">BDR</div>	
		BD-ROM(Multiple Layer) <div style="border: 1px solid black; padding: 5px; width: fit-content; margin: 5px auto;">BDXROM</div>	
		BD-RE(Multiple Layer) <div style="border: 1px solid black; padding: 5px; width: fit-content; margin: 5px auto;">BDXRE</div>	
		BD-R(Multiple Layer) <div style="border: 1px solid black; padding: 5px; width: fit-content; margin: 5px auto;">BDXR</div>	
		Others <div style="border: 1px solid black; padding: 5px; width: fit-content; margin: 5px auto;">MEDIA*</div>	
		* s displayed the respeced value from RTSC. 6. Disc maker ID is displayed for 5 seconds. <div style="border: 1px solid black; padding: 5px; width: fit-content; margin: 5px auto;">*****</div>	In case that the maker cannot be identified, display is black out.

Item		FL Display	Key Operation (Remote controller key)																																																																																																					
Mode Name	Description																																																																																																							
		<p>7. Factor of drive error (hexadecimal) occurring is left displayed.</p> <div style="border: 1px solid black; padding: 5px; text-align: center; width: fit-content; margin: 10px auto;">* * + + & &</div> <p>* * : Error occurring operation code (This is not used)</p> <p>+ + : Error occurring disc type</p> <table border="1" style="margin-left: auto; margin-right: auto;"> <tr><td>00</td><td>DVD-ROM</td></tr> <tr><td>01</td><td>CD</td></tr> <tr><td>02</td><td>2.6GB DVD-RAM</td></tr> <tr><td>03</td><td>4.7GB DVD-RAM</td></tr> <tr><td>04</td><td>DVD-R</td></tr> <tr><td>After 05</td><td>Others</td></tr> </table> <p>&& : Error occurring disc situation</p> <table border="1" style="margin-left: auto; margin-right: auto;"> <thead> <tr> <th rowspan="2">Display</th> <th colspan="4">Detail</th> </tr> <tr> <th>Disc distinction</th> <th>With or without Cartridge</th> <th>Disc cartridge state</th> <th>Size</th> </tr> </thead> <tbody> <tr><td>00</td><td>OK</td><td>With</td><td>Not opened</td><td>12cm</td></tr> <tr><td>10</td><td>OK</td><td>With</td><td>Not opened</td><td>8cm</td></tr> <tr><td>20</td><td>OK</td><td>With</td><td>Opened</td><td>12cm</td></tr> <tr><td>30</td><td>OK</td><td>With</td><td>Opened</td><td>8cm</td></tr> <tr><td>40</td><td>OK</td><td>Without</td><td>Not opened</td><td>12cm</td></tr> <tr><td>50</td><td>OK</td><td>Without</td><td>Not opened</td><td>8cm</td></tr> <tr><td>60</td><td>OK</td><td>Without</td><td>Opened</td><td>12cm</td></tr> <tr><td>70</td><td>OK</td><td>Without</td><td>Opened</td><td>8cm</td></tr> <tr><td>80</td><td>NG</td><td>With</td><td>Not opened</td><td>12cm</td></tr> <tr><td>90</td><td>NG</td><td>With</td><td>Not opened</td><td>8cm</td></tr> <tr><td>A0</td><td>NG</td><td>With</td><td>Opened</td><td>12cm</td></tr> <tr><td>B0</td><td>NG</td><td>With</td><td>Opened</td><td>8cm</td></tr> <tr><td>C0</td><td>NG</td><td>Without</td><td>Not opened</td><td>12cm</td></tr> <tr><td>D0</td><td>NG</td><td>Without</td><td>Not opened</td><td>8cm</td></tr> <tr><td>E0</td><td>NG</td><td>Without</td><td>Opened</td><td>12cm</td></tr> <tr><td>F0</td><td>NG</td><td>Without</td><td>Opened</td><td>8cm</td></tr> </tbody> </table> <p>8. When the last error doesn't exist.</p> <div style="border: 1px solid black; padding: 5px; text-align: center; width: fit-content; margin: 10px auto;">NO DATA</div>	00	DVD-ROM	01	CD	02	2.6GB DVD-RAM	03	4.7GB DVD-RAM	04	DVD-R	After 05	Others	Display	Detail				Disc distinction	With or without Cartridge	Disc cartridge state	Size	00	OK	With	Not opened	12cm	10	OK	With	Not opened	8cm	20	OK	With	Opened	12cm	30	OK	With	Opened	8cm	40	OK	Without	Not opened	12cm	50	OK	Without	Not opened	8cm	60	OK	Without	Opened	12cm	70	OK	Without	Opened	8cm	80	NG	With	Not opened	12cm	90	NG	With	Not opened	8cm	A0	NG	With	Opened	12cm	B0	NG	With	Opened	8cm	C0	NG	Without	Not opened	12cm	D0	NG	Without	Not opened	8cm	E0	NG	Without	Opened	12cm	F0	NG	Without	Opened	8cm	
00	DVD-ROM																																																																																																							
01	CD																																																																																																							
02	2.6GB DVD-RAM																																																																																																							
03	4.7GB DVD-RAM																																																																																																							
04	DVD-R																																																																																																							
After 05	Others																																																																																																							
Display	Detail																																																																																																							
	Disc distinction	With or without Cartridge	Disc cartridge state	Size																																																																																																				
00	OK	With	Not opened	12cm																																																																																																				
10	OK	With	Not opened	8cm																																																																																																				
20	OK	With	Opened	12cm																																																																																																				
30	OK	With	Opened	8cm																																																																																																				
40	OK	Without	Not opened	12cm																																																																																																				
50	OK	Without	Not opened	8cm																																																																																																				
60	OK	Without	Opened	12cm																																																																																																				
70	OK	Without	Opened	8cm																																																																																																				
80	NG	With	Not opened	12cm																																																																																																				
90	NG	With	Not opened	8cm																																																																																																				
A0	NG	With	Opened	12cm																																																																																																				
B0	NG	With	Opened	8cm																																																																																																				
C0	NG	Without	Not opened	12cm																																																																																																				
D0	NG	Without	Not opened	8cm																																																																																																				
E0	NG	Without	Opened	12cm																																																																																																				
F0	NG	Without	Opened	8cm																																																																																																				

Item		FL Display	Key Operation (Remote controller key)															
Mode Name	Description																	
Laser power test	Drive state is judged based on difference between laser power value at shipping and present laser power value.	<p>Measuring stars (Measuring in process).</p> <div style="border: 1px solid black; padding: 5px; width: fit-content; margin: 5px auto;">POWER</div> <p>When the measuring result is OK.</p> <div style="border: 1px solid black; padding: 5px; width: fit-content; margin: 5px auto;">OK *</div> <p>When the measuring result is NG.</p> <div style="border: 1px solid black; padding: 5px; width: fit-content; margin: 5px auto;">NG *</div> <p>When DVD-RAM is not inserted.</p> <div style="border: 1px solid black; padding: 5px; width: fit-content; margin: 5px auto;">NODISC</div> <p>When an error occurs while measuring.</p> <div style="border: 1px solid black; padding: 5px; width: fit-content; margin: 5px auto;">ERROR</div> <p>* is judgement result</p> <table border="1" style="margin: 5px auto;"> <thead> <tr> <th>*</th> <th>Power value difference</th> <th>Evaluation</th> </tr> </thead> <tbody> <tr> <td>0</td> <td>1mW or less</td> <td>Very good.</td> </tr> <tr> <td>1</td> <td>2mW or less</td> <td>Good.</td> </tr> <tr> <td>2</td> <td>3mW or less</td> <td>Bad.</td> </tr> <tr> <td>3</td> <td>4mW or more</td> <td>Very bad.</td> </tr> </tbody> </table> <p>If disc in not inserteed, [NO DISC] is displayed. If power value study was filed, [ERROR] is displayed.</p>	*	Power value difference	Evaluation	0	1mW or less	Very good.	1	2mW or less	Good.	2	3mW or less	Bad.	3	4mW or more	Very bad.	<p>1. Insert the 5X media DVD-RAM into the tray. (Incompatible with other media) 2. Press [4] [4].</p>
*	Power value difference	Evaluation																
0	1mW or less	Very good.																
1	2mW or less	Good.																
2	3mW or less	Bad.																
3	4mW or more	Very bad.																
CEC (H) output	Check of the CEC terminal high output of HDMI.	<p>When the check is OK</p> <div style="border: 1px solid black; padding: 5px; width: fit-content; margin: 5px auto;">CECHOK</div> <p>When the check is NG</p> <div style="border: 1px solid black; padding: 5px; width: fit-content; margin: 5px auto;">CECHNG</div>	Press [5] [5] in service mode.															
CEC (L) output	Check of the CEC terminal low output of HDMI.	<p>When the check is OK</p> <div style="border: 1px solid black; padding: 5px; width: fit-content; margin: 5px auto;">CECLOK</div> <p>When the check is NG</p> <div style="border: 1px solid black; padding: 5px; width: fit-content; margin: 5px auto;">CECLNG</div>	Press [5] [6] in service mode.															
Production Date Display	Display the date when the unit was produced.	<div style="border: 1px solid black; padding: 5px; width: fit-content; margin: 5px auto;">YYMMDD</div> <p>YY: Year MM: Month DD: Day</p>	Press [6] [1] in service mode.															

Item		FL Display	Key Operation (Remote controller key)
Mode Name	Description		
Display the Error History	Display the Error History stored on the unit. * If the current date or the date when the error occurred is wrong, correct judgement may not be made.	<p>When the drive malfunction was detected within 4 weeks ago. (*)</p> <div style="border: 1px solid black; padding: 5px; width: fit-content; margin: 5px auto;">DRV NG</div> <p>When the drive malfunction was detected more than 4 weeks ago or Drive last error data does not exist.</p> <div style="border: 1px solid black; padding: 5px; width: fit-content; margin: 5px auto;">DRV OK</div> <p>When HDD Self-Diagnosis test result is NG.</p> <div style="border: 1px solid black; padding: 5px; width: fit-content; margin: 5px auto;">HDD NG</div> <p>When HDD Self-Diagnosis test result is OK.</p> <div style="border: 1px solid black; padding: 5px; width: fit-content; margin: 5px auto;">HDD OK</div> <p>The Error History is not Data for HDD and BD Drive.</p> <div style="border: 1px solid black; padding: 5px; width: fit-content; margin: 5px auto;">OK</div> <p>The Error History is not Data.</p> <div style="border: 1px solid black; padding: 5px; width: fit-content; margin: 5px auto;">NODATA</div> <p>HDD Self-Diagnosis test in process.</p> <div style="border: 1px solid black; padding: 5px; width: fit-content; margin: 5px auto;">HDDCHK</div>	Press [6] [5] in service mode.
Save the error history to SD card	The error and user operation history of the remote control are saved to the SD card.	<p>The SD card cannot be recognized</p> <div style="border: 1px solid black; padding: 5px; width: fit-content; margin: 5px auto;">NOCARD</div> <p>During saving</p> <div style="border: 1px solid black; padding: 5px; width: fit-content; margin: 5px auto;">SDSAVE</div> <p>Save end</p> <div style="border: 1px solid black; padding: 5px; width: fit-content; margin: 5px auto;">FIN</div>	Press [6] [9] in service mode.
For usual recording, registration of additional USB HDD	To register USB HDD for inspection. (Special mode)	<p>When USB HDD is in Special mode (available for registered USB HDD):</p> <div style="border: 1px solid black; padding: 5px; width: fit-content; margin: 5px auto;">EXTCHD</div> <p>When Special mode failure (USB-HDD registration impossible):</p> <div style="border: 1px solid black; padding: 5px; width: fit-content; margin: 5px auto;">EXT NG</div>	<p>Press [7] [4] in service mode.</p> <p>* When releasing this mode, press the [POWER] button of the unit or Remote Control. After releasing the special mode, registration in the special mode is cancelled.</p> <p>Details are described in "3.1.3.1. Registering the USB HDD".</p>

Item		FL Display	Key Operation (Remote controller key)
Mode Name	Description		
USB HDD READ SEEK Inspection	Inspecting seek time of USB HDD to inspect performance.	<p>At start</p> <div style="border: 1px solid black; padding: 5px; text-align: center; margin-bottom: 5px;">AVSCAN</div> <p style="text-align: center;">↓</p> <div style="border: 1px solid black; padding: 5px; text-align: center; margin-bottom: 5px;">* 00</div> <p style="text-align: center;">↓</p> <p>The [*] sign is added every approx. 10 seconds while inspecting. Two digits on the right side are the progress level of the inspection (The unit is %). Example on the way of inspection:</p> <div style="border: 1px solid black; padding: 5px; text-align: center; margin-bottom: 5px;">*** 53</div> <p>When USB HDD is OK after inspection:</p> <div style="border: 1px solid black; padding: 5px; text-align: center; margin-bottom: 5px;">HDD OK</div> <p>(NG is displayed when error is excluding 0) (Transfer rate is calculated from the AV scanning result, and when it is less than 35Mbps, NG is displayed.)</p> <div style="border: 1px solid black; padding: 5px; text-align: center; margin-bottom: 5px;">HDD\$##</div> <p>\$: [X] is displayed when seek time is over 270msec., there is error or transfer rate is NG. Position at \$ is space when excluding those. ##: Number of data of over 100msec. and less than 270msec. When it is over 100, [99] is displayed. When the number is less than 5, we judge it normal. When the USB HDD is not applicable.</p> <div style="border: 1px solid black; padding: 5px; text-align: center; margin-bottom: 5px;">NO_SUP</div>	<p>Press [7] [5] in service mode. * When cancelling the inspection mode while executing, do "forced power-off". Method: Press [POWER] key on the main unit more than 4 seconds.</p>

Item		FL Display	Key Operation (Remote controller key)
Mode Name	Description		
USB HDD READ VERIFY Inspection	Measure of access time in READ VERIFY MODE of USB HDD.	<p>At start</p> <div style="border: 1px solid black; padding: 5px; text-align: center; margin-bottom: 5px;">AVSCAN</div> <p style="text-align: center;">↓</p> <div style="border: 1px solid black; padding: 5px; text-align: center; margin-bottom: 5px;">* 00</div> <p style="text-align: center;">↓</p> <p>The [*] sign is added every approx. 10 seconds while inspecting. Two digits on the right side are the progress level of the inspection (The unit is %). Example on the way of inspection:</p> <div style="border: 1px solid black; padding: 5px; text-align: center; margin-bottom: 5px;">*** 53</div> <p>When USB HDD is OK after inspection:</p> <div style="border: 1px solid black; padding: 5px; text-align: center; margin-bottom: 5px;">HDD OK</div> <p>(NG is displayed when error is excluding 0) (Transfer rate is calculated from the AV scanning result, and when it is less than 35Mbps, NG is displayed.)</p> <div style="border: 1px solid black; padding: 5px; text-align: center; margin-bottom: 5px;">HDD\$##</div> <p>\$: [X] is displayed when seek time is over 270msec., there is error or transfer rate is NG. Position at \$ is space when exclud- ing those. ##: Number of data of over 100msec. and less than 270msec. When it is over 100, [99] is displayed. When the number is less than 5, we judge it normal. When the USB HDD is not applicable.</p> <div style="border: 1px solid black; padding: 5px; text-align: center; margin-bottom: 5px;">NO_SUP</div>	<p>Press [7] [6] in service mode. * When cancelling the inspection mode while executing, do "forced power-off". Method: Press [POWER] key on the main unit more than 4 seconds.</p>

Item		FL Display	Key Operation (Remote controller key)
Mode Name	Description		
USB HDD Simple AV Scan Check	Simple AV scan check of USB HDD	<div style="text-align: center;"> <div style="border: 1px solid black; padding: 5px; width: fit-content; margin: 0 auto;">AVSCAN</div> <p style="text-align: center;">↓</p> <div style="border: 1px solid black; padding: 5px; width: fit-content; margin: 0 auto;">STEP 01</div> <p style="text-align: center;">↓</p> <div style="border: 1px solid black; padding: 5px; width: fit-content; margin: 0 auto;">STEP 07</div> <p style="text-align: center;">↓</p> <div style="border: 1px solid black; padding: 5px; width: fit-content; margin: 0 auto;">* 00</div> <p style="text-align: center;">↓</p> <p>The [*] sign is added every 10 seconds while inspecting. Two digits on the right side are the progress level of the inspection (The unit is %). Example on the way of inspection:</p> <div style="border: 1px solid black; padding: 5px; width: fit-content; margin: 0 auto;">*** 53</div> <p>When USB HDD is OK after inspection:</p> <div style="border: 1px solid black; padding: 5px; width: fit-content; margin: 0 auto;">HDD OK</div> <p>When USB HDD is NG after inspection:</p> <div style="border: 1px solid black; padding: 5px; width: fit-content; margin: 0 auto;">HDD ***</div> <p>[*] is the number of data of NG.</p> </div>	Press [7] [7] in service mode. * When cancelling the inspection mode while executing, do "forced power-off". Method: Press [POWER] key on the main unit more than 4 seconds.
USB HDD Check	Simple quality judgement of USB HDD	<div style="text-align: center;"> <div style="border: 1px solid black; padding: 5px; width: fit-content; margin: 0 auto;">HDDCHK</div> <p style="text-align: center;">↓</p> <p>When USB HDD is OK:</p> <div style="border: 1px solid black; padding: 5px; width: fit-content; margin: 0 auto;">HDD OK</div> <p>When USB HDD is NG:</p> <div style="border: 1px solid black; padding: 5px; width: fit-content; margin: 0 auto;">HDD NG</div> </div>	Press [7] [8] in service mode.
Tray OPEN/CLOSE Test	The tray is opened and closed repeatedly.	<div style="text-align: center;"> <div style="border: 1px solid black; padding: 5px; width: fit-content; margin: 0 auto;">*****</div> <p>“*” is number of open/close cycle times.</p> </div>	Press [9] [1] in service mode *When releasing this mode, press the [POWER] button of Remote Controller.

Item		FL Display	Key Operation
Mode Name	Description		(Remote controller key)
Delete the Laser Used Time	Laser used time stored in the memory of the unit is deleted.	CLR	Press [9] [5] in service mode.
Delete the Last Drive Error	Delete the Last Drive Error information stored on the BD Drive.	CLR	Press [9] [6] in service mode.
Delete the Error History	Delete Error History information stored on the unit is deleted.	CLR	Press [9] [7] in service mode.
Error code Initialization	Information of the last error code held by timer. (Write in F00)	CLR	Press [9] [8] in service mode.
Initialize Service	Last Drive Error, Error History and Error code information stored on the unit are initialized to factory setting.	CLR	Press [9] [9] in service mode.
Finishing service mode	Release Service Mode.	Display in STOP (E-E) mode. *****	Press power button on the front panel or Remote controller in service mode.

8 Service Fixture & Tools

Part Number	Description	Pcs	Compatibility
RFKZ0216	Extension Cable (Digital P.C.B. - Main P.C.B./ 23 Pin)	1	Same as BWT945 Series
RFKZ0455	Extension Cable (Digital P.C.B. - HDD / 7 Pin)	1	Same as BWT945 Series
RFKZ0577	Extension Cable (Digital P.C.B. - HDD / 15 Pin)	1	Same as BWT945 Series
SUKZ000007 (*1)	Extension Cable (Digital P.C.B. - BD Drive / 18 Pin)	1	Same as BWT945 Series
SVKZ000001	Lead Free Solder (0.3mm/100g Reel)		Same as BWT945 Series
SVKZ000002	Lead Free Solder (0.6mm/100g Reel)		Same as BWT945 Series
SVKZ000003	Lead Free Solder (1.0mm/100g Reel)		Same as BWT945 Series
RFKZ0316	Solder Remover (Lead free low temperature Solder/50g)		Same as BWT945 Series
RFKZ0328	Flux		Same as BWT945 Series

* The above parts are supplied by AVC-CSC-SPC.

*1. Supplied by CHPAVC.

9 Disassembly and Assembly Instructions

9.1. Disassembly flow chart

The following chart is the procedure for disassembling the casing and inside parts for internal inspection when carrying out the servicing.

To assemble the unit, reverse the steps shown in the chart below.

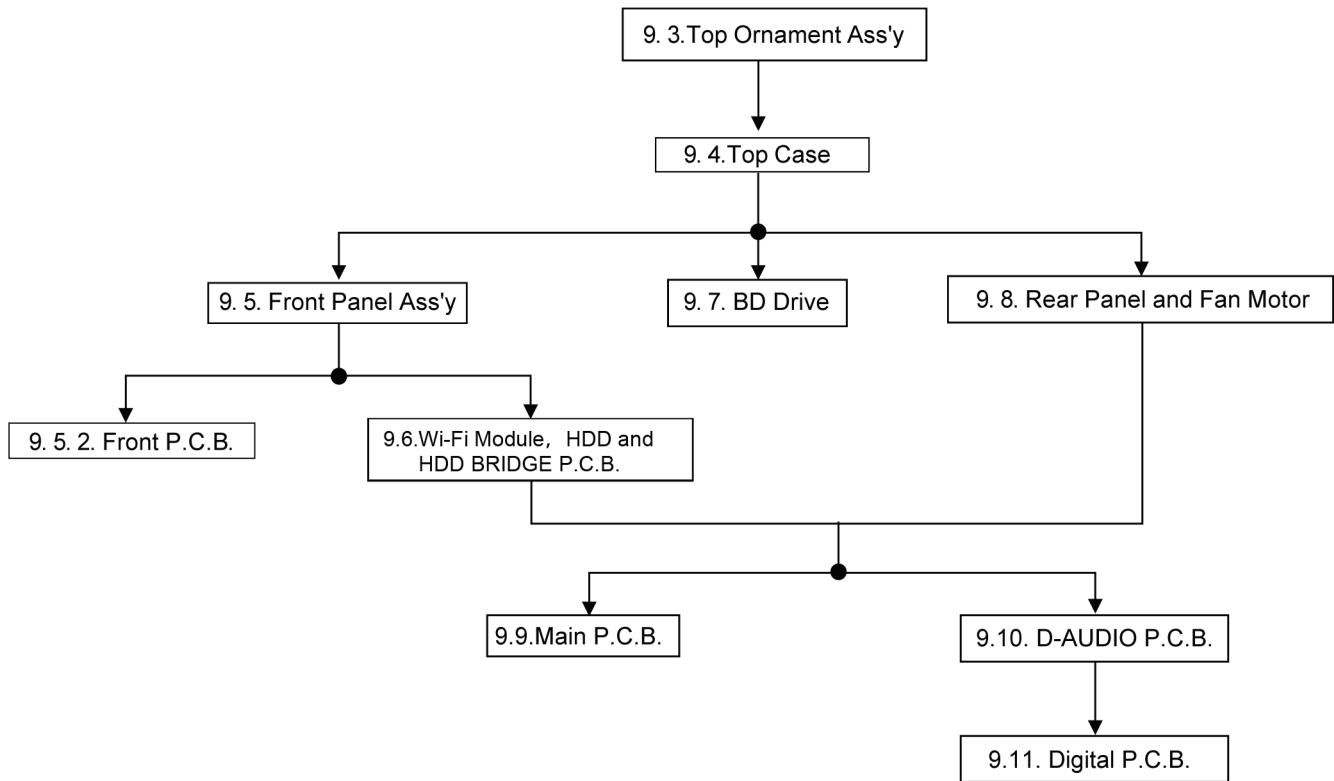

9.2. P.C.B. Positions

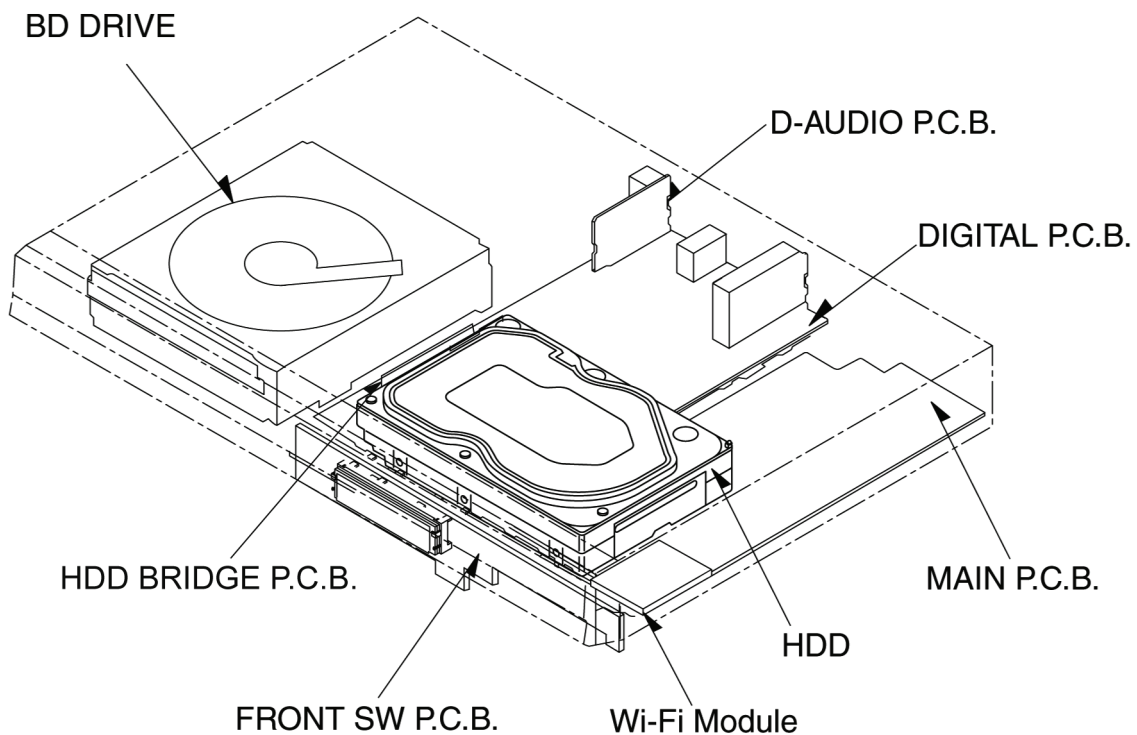

9.3. Top Ornament Ass'y

1. Remove the 3 screws (A) to remove Top Ornament Ass'y.

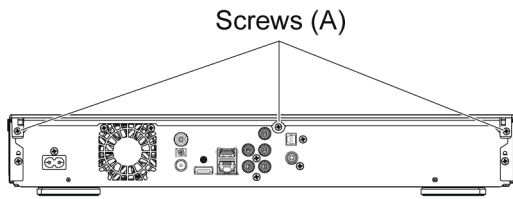

2. Slide the Ornament Ass'y rearward and lift the Ornament Ass'y in the direction of the arrows.

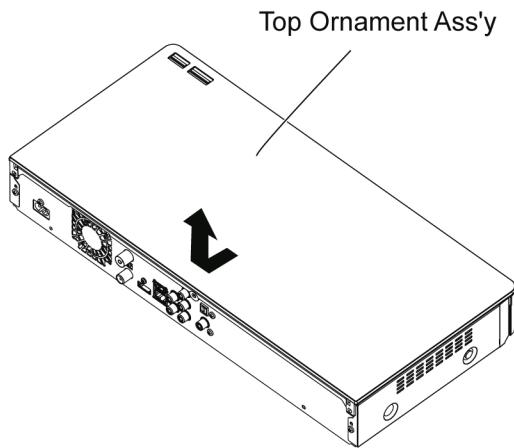

Caution:

1. In the process of component composition, please don't damage the Function Buttons and TOP ORNAMENT (COVER) ASS'Y Claws.
2. First, score on both sides of the screw, and then into the middle screw while assembling.

9.4. Top Case

1. Remove the 2 screws (A) and 2 screws (B).

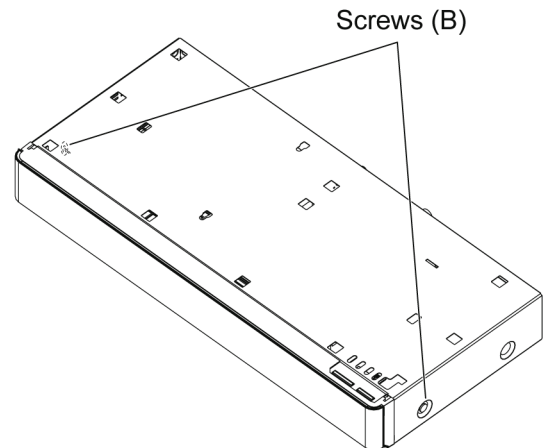
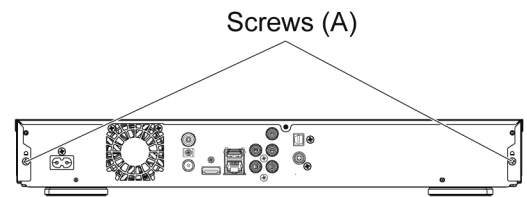

2. Slide the Top Case rearward and open the both ends at rear side of the Top Case a little and lift the Top Case in the direction of the arrows.

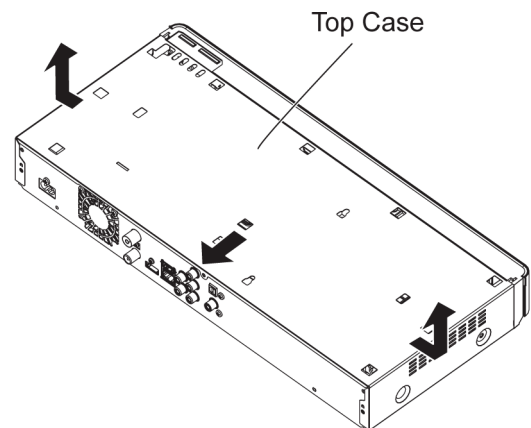

9.5. Front Panel Ass'y

9.5.1. Front Panel

1. Unlock 6 tabs (A) - (F).

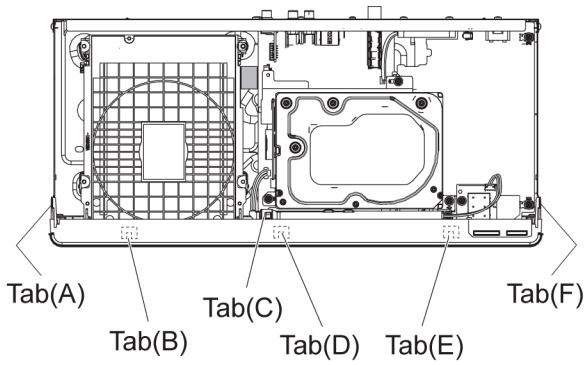

2. Pull with the front panel in the direction of your side.

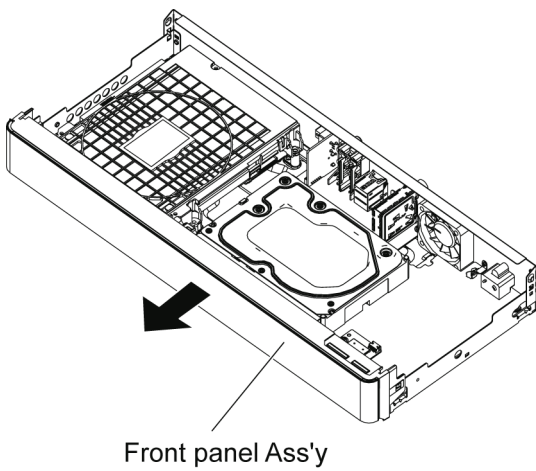

9.5.2. Front P.C.B.

1. Remove the 3 Screws (A).
2. Unlock 1 tab (A).

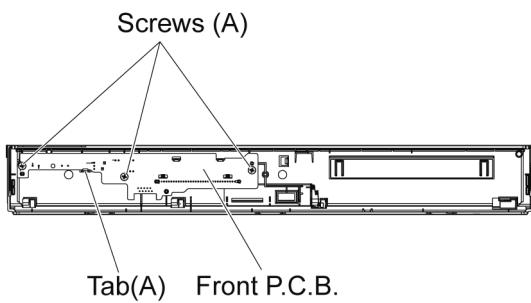

9.5.3. How to assemble Door ass'y

1. Application of the Lubricant to Door Ass'y.

- a. Lubrication points on Door ass'y and Front Panel are shown in the figure as below.

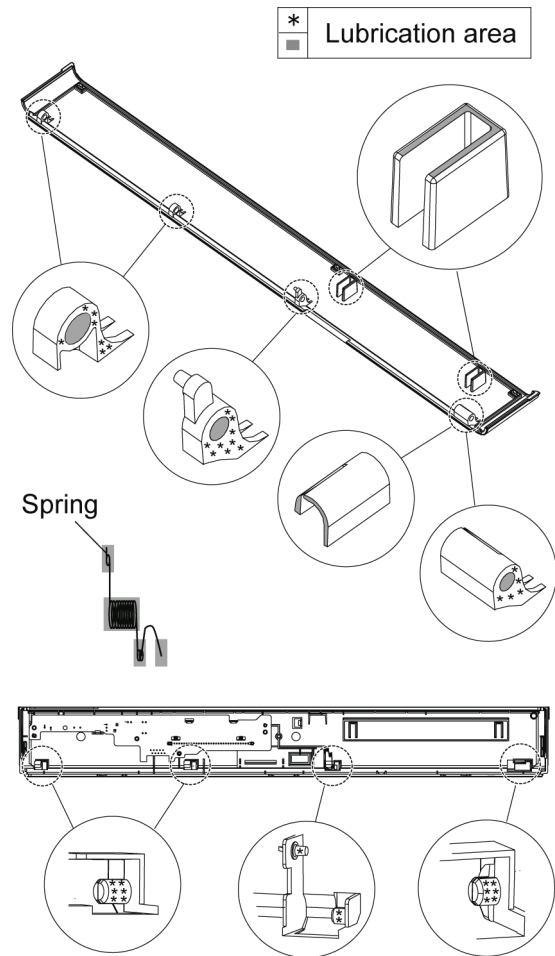

- b. Since the replaced parts are not lubricated, please apply lubricant to the specified points (RFKXGUD24).
- c. Use Cotton Swab to spread thinly.

2. Install each roller of the door in the sequence as shown in the figure.

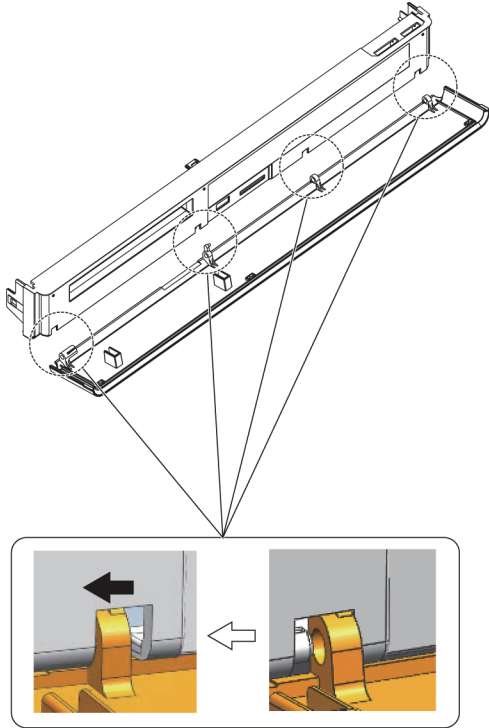

3. Install 1 springs in place in the sequence as shown in the figure.

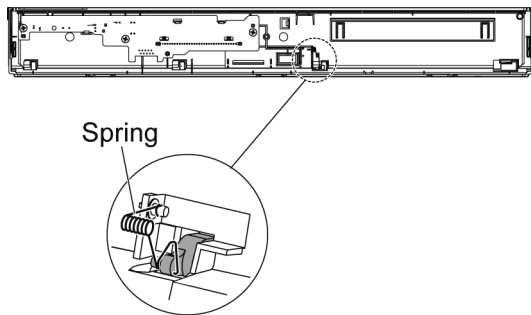

9.6. Wi-Fi Module, HDD and HDD BRIDGE P.C.B.

Data of HDD:

Make sure to order the Part No., SUCV****HDK in Replacement Parts List when replacing the HDD.

The following data has been written on SUCV****HDK.

- Main Firm
- CD DB Data
- Other Data

Caution:

No use HDD (SUCV****HDK) of the capacity of the other model use.

When replacing HDD, "HDD Error" indication is displayed and HDD must be formatted.

*How to format HDD

Please refer to Service Navigation, and Format HDD.

Handling of HDD

The following precautions should be taken when handling HDD.

- a. Never give an impact to HDD. (Even a drop from 1cm height can be a cause of HDD failure.
- b. When placing HDD on a workbench, provide a mat on a bench for shock absorption and anti-static purposes.
- c. When installing HDD, release it from your hands only after confirming that it is fully set on the chassis.
- d. Avoid stacking up HDD.
- e. HDD is unstable and easy to fall. Do not stand it on its side face.
- f. When handling HDD, hold its side faces to avoid static hazard.
- g. Do not place HDD on its wrapping bag after removal. (Prevention of static hazard)
- h. Use a screwdriver with low impact and anti-static features.

Note:

When replacing HDD, please make the rear jumper slave or cable select configuration.

1. Disconnect the two connectors of WLAN Cable.

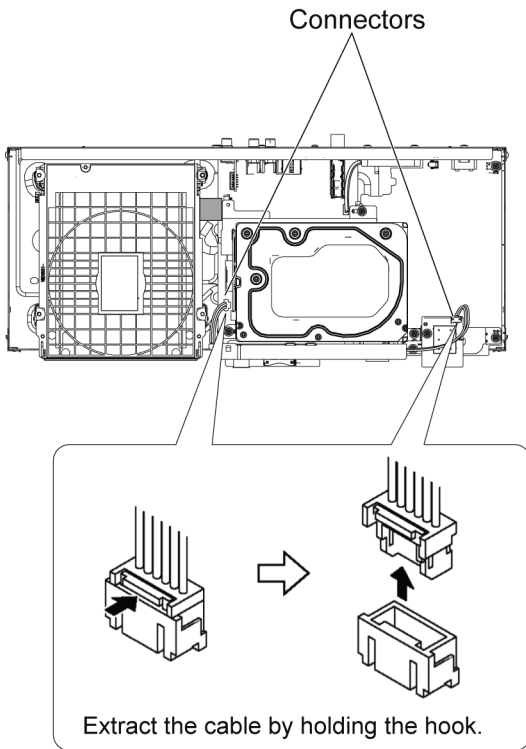

2. Remove 2 Screws (A) to remove Wi-Fi Module and Wi-Fi BRACKET.

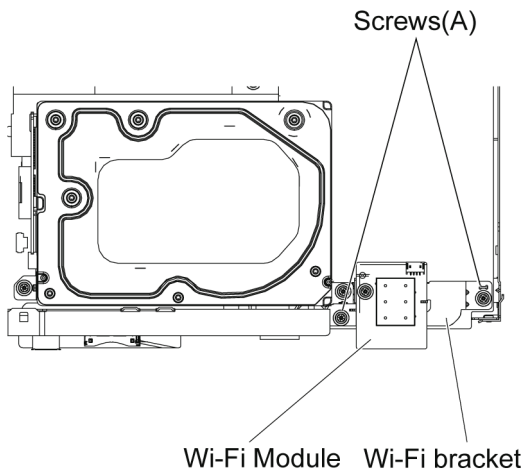

3. Remove 1 Screw (A) to remove Wi-Fi Module.

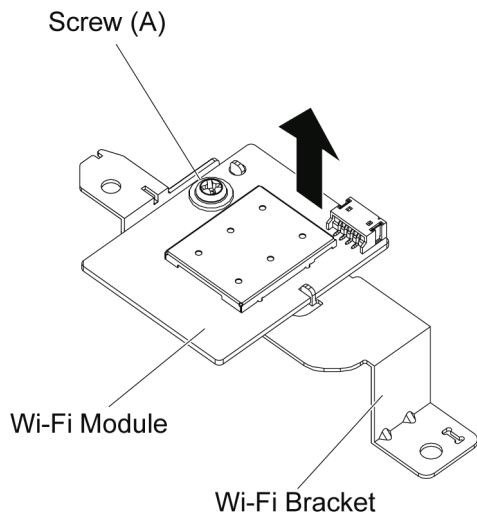

4. Remove 4 Screws (A) and disconnect the connector of HDD BRIDGE P.C.B. to remove HDD ass'y.

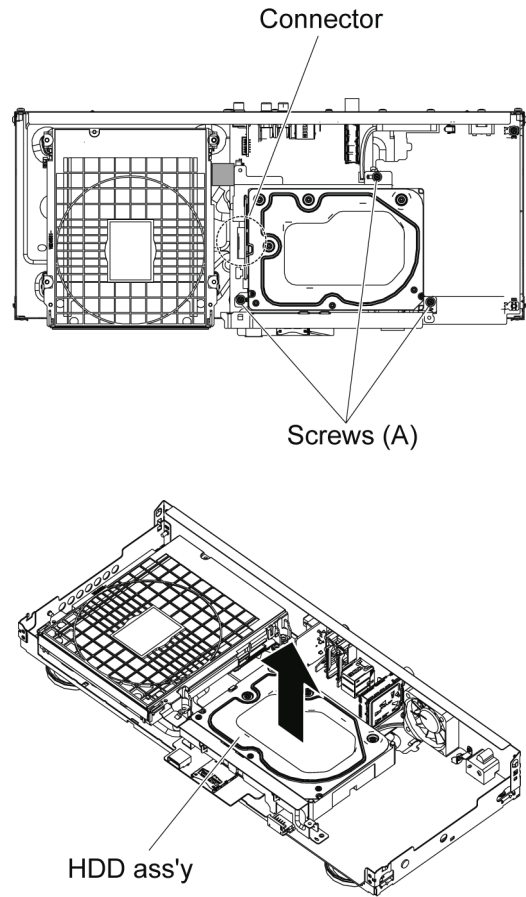

5. Put HDD up and down inversely so as not to give a shock to HDD.

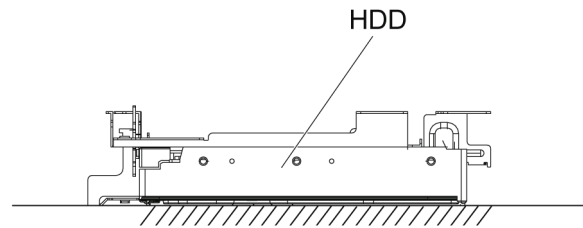

6. Remove 4 Screws (B) to remove HDD from HDD Bracket.

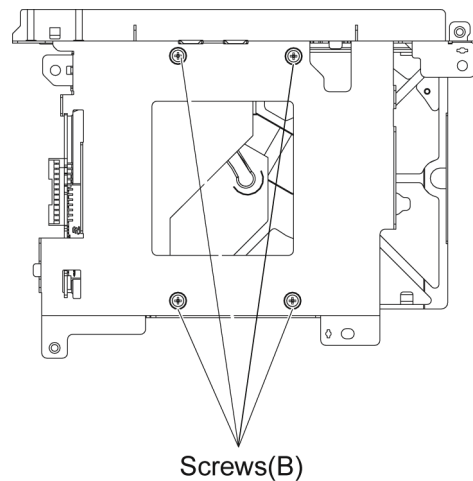

7. Pull up HDD BRIDGE P.C.B. in the direction of the arrow.

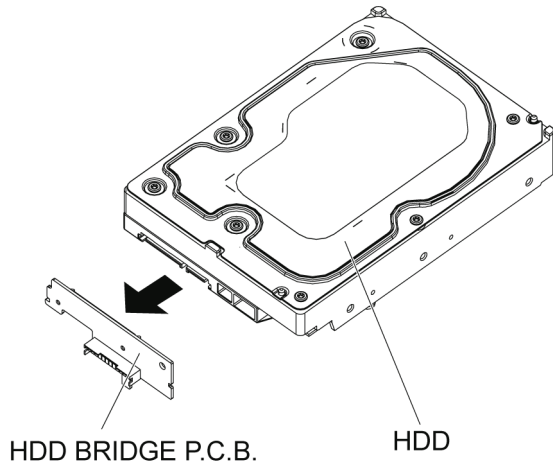

9.7. BD Drive

1. Disconnect the connector of DRIVE FFC .
2. Remove the 4 Screws (A) to remove BD Drive.

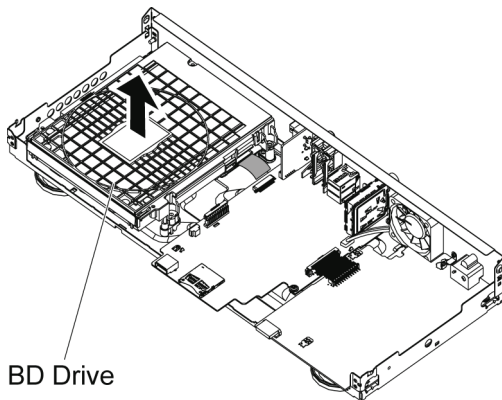
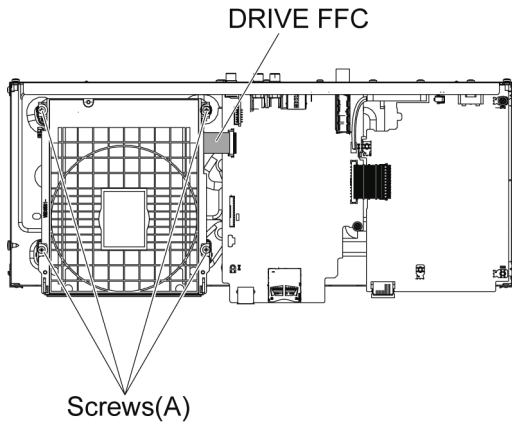

9.8. Rear Panel and Fan Motor

9.8.1. Only Fan Motor

1. Remove 2 Screws (A) and disconnect the Fan connector.

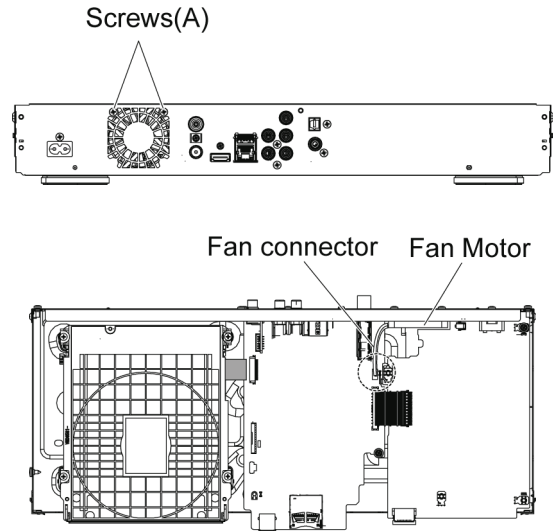

2. Remove the Fan Motor.

9.8.2. Rear Panel with Fan Motor

1. Remove 5 Screws (A) and 2 Screws (B).

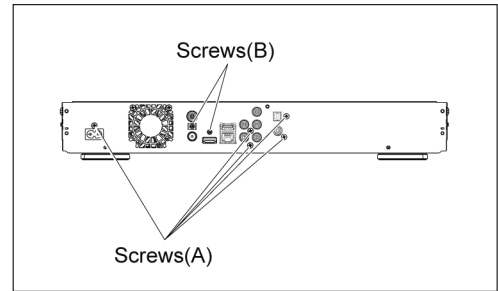

2. Disconnect the Fan connector and unlock 2 locking tabs (C) to remove Rear Panel.

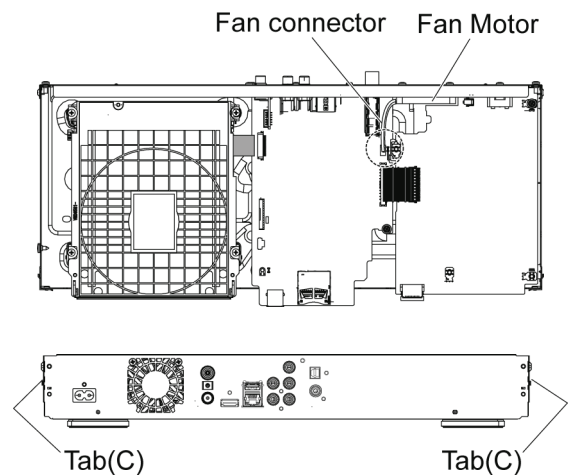

9.9. Main P.C.B.

1. Disconnect 1 connector (A).
2. Remove 1 Screws (A) to remove Main P.C.B.

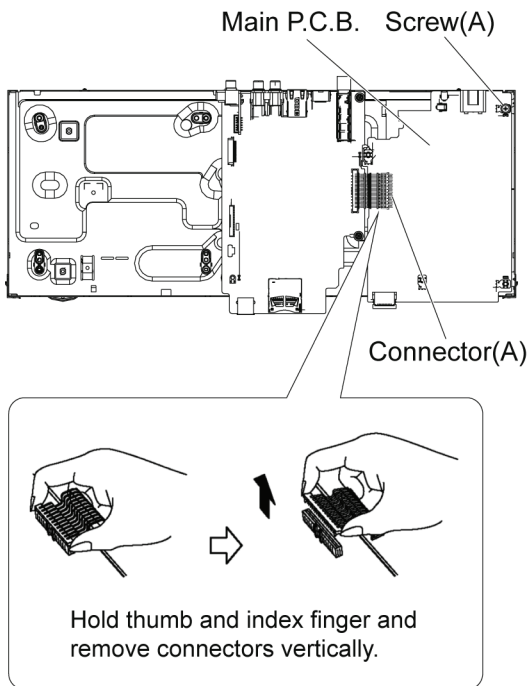

9.11. Digital P.C.B.

1. Disconnect 1 connector(A).
2. Remove 3 Screws(A) to remove Digital P.C.B..

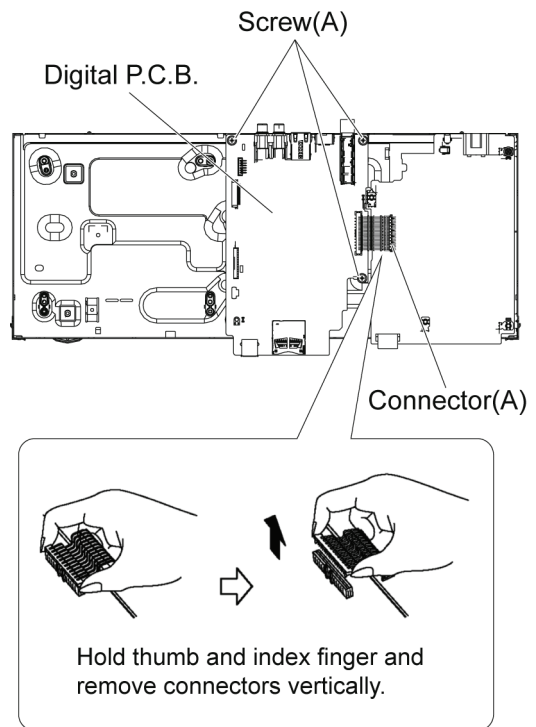

9.10. D-AUDIO P.C.B.

When replacing D-AUDIO P.C.B., "HDD Error" indication is displayed and HDD must be formatted.

*How to format HDD
Please refer to Service Navigation,
and Format HDD.

1. Pull up D-AUDIO P.C.B. in the direction of the arrow.

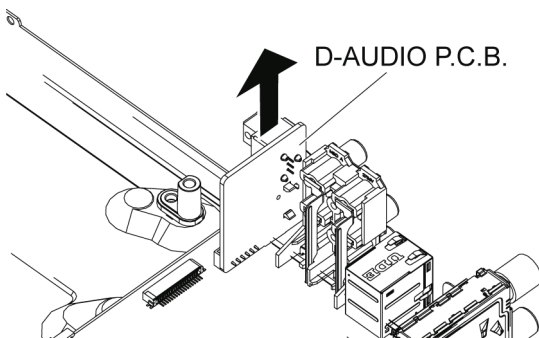

9.12. BD Drive

9.12.1. Upper Base Ass'y

1. Remove 3 Screws(A), and push the 2 Hooks in.

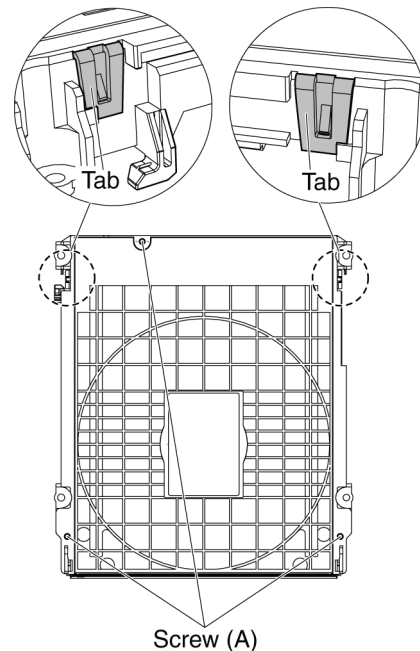

2. Lift up the Upper Base Ass'y, and pull it out to the direction of arrow.

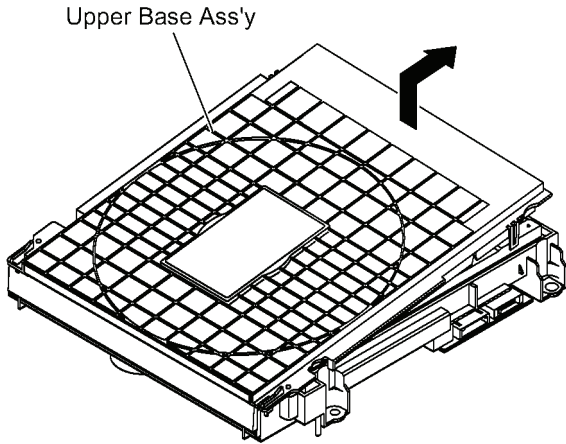

Notes when attaching the tray:

Pull the Slide Cam to the left side and insert the tray when attaching.

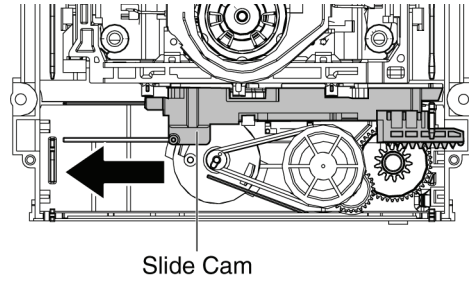

9.12.2. Tray

1. Perform the step "9.12.1.Upper Base Ass'y".
2. Insert the Paper Clip into the hole of the bottom side, and slide it to the direction of arrow until it can be.

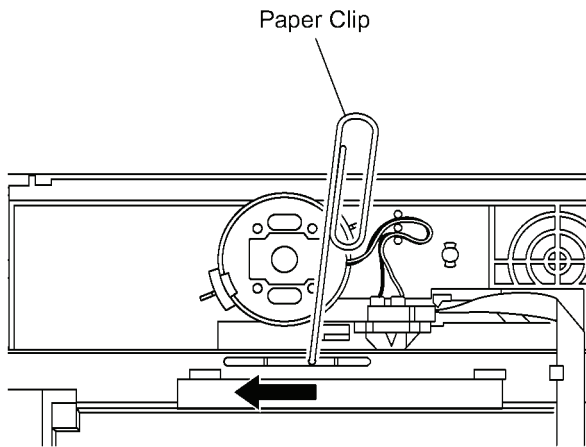

9.12.3. Pulley Gear, Belt and Mid Gear

1. Perform the step "9.12.2.Tray".
2. Push the post to the direction of arrow by using the slotted screwdriver.

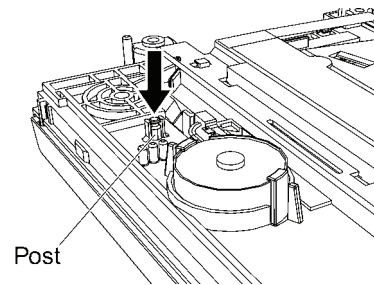

3. Remove the Pulley Gear, Belt and Mid Gear.

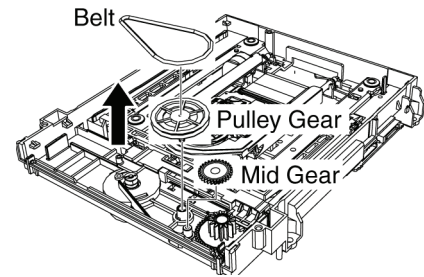

3. Pull the Tray to the direction of arrow.

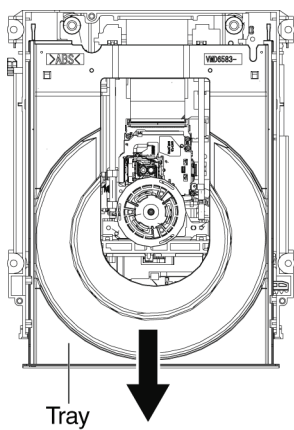

9.12.4. Slide Cam

1. Perform the step "9.12.3.Pulley Gear,Belt and Mid Gear".
2. Remove the sheet.
3. Open the connector lock,and disconnect the 4 FFCs.
4. Remove the Screw (A),Heat Sink and Drive P.C.B..

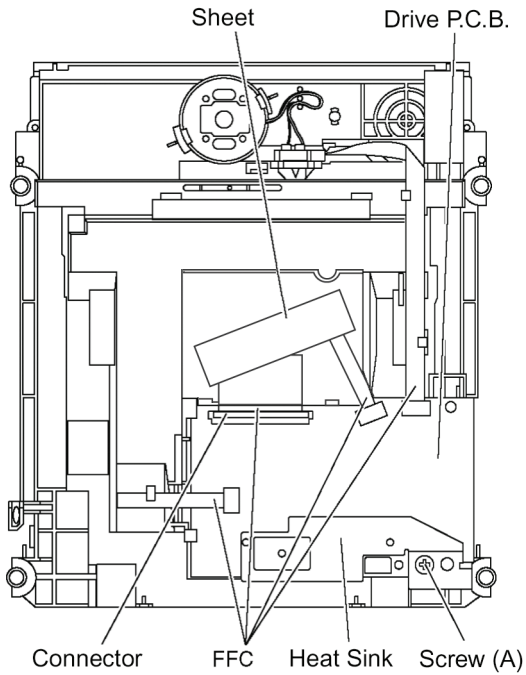

Caution:

Though the Drive P.C.B. is not supplied as replacement parts,it must be removed for after disassembling.

5. Remove the 2 Dampers.

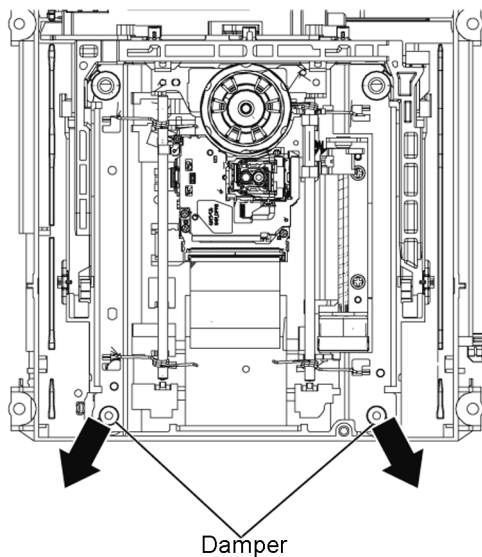

6. Open the connector lock,and disconnect the OPU FFC.
7. Pull the Slide Cam to the right side.

8. Remove the Traverse Base Ass'y with spreading the 2 Hooks to the direction of arrows.

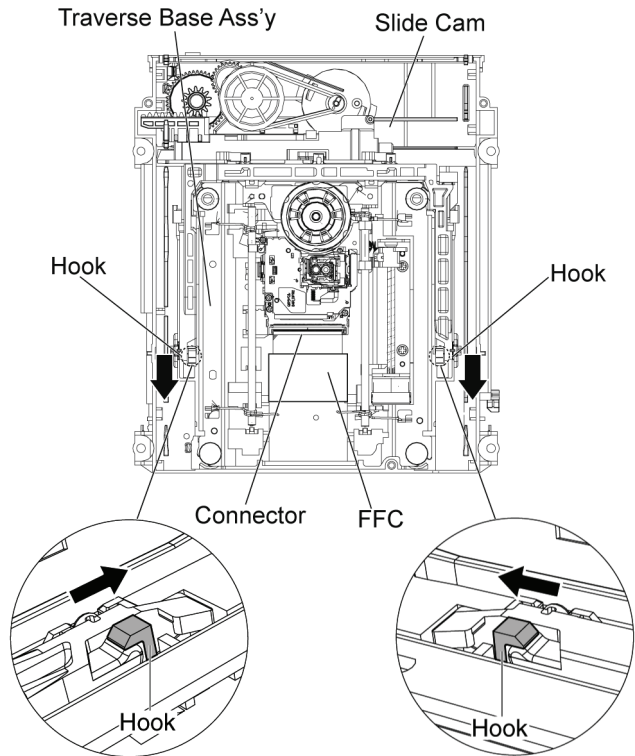

9. Remove the Slide Cam.

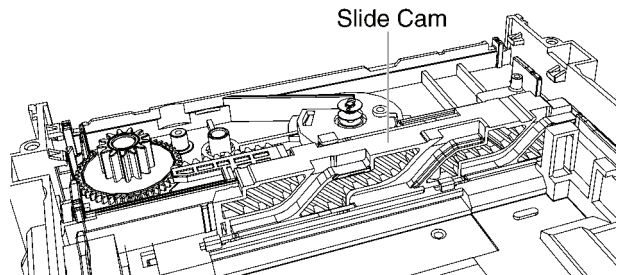

9.12.5. Drive Gear and Loading Motor

1. Perform the step "9.12.4.Slide Cam".
2. Remove the Drive Gear.

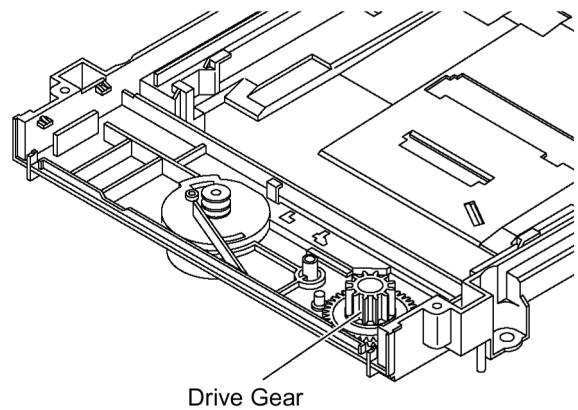

3. Remove the 2 soldering points.

4. Spread the 2 hooks to remove the Loading Motor.

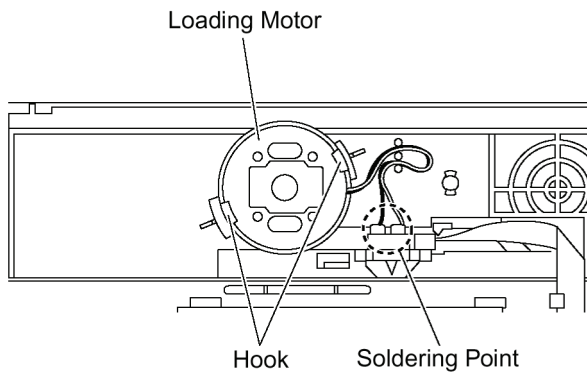

Notes when assembling:

- a. Align the location hole of the loading motor with the base dowel pin.
- b. The fixing style for the wire rod of the loading motor is shown in the figure.
- c. The stationary jaw of FFC is shown in the figure.

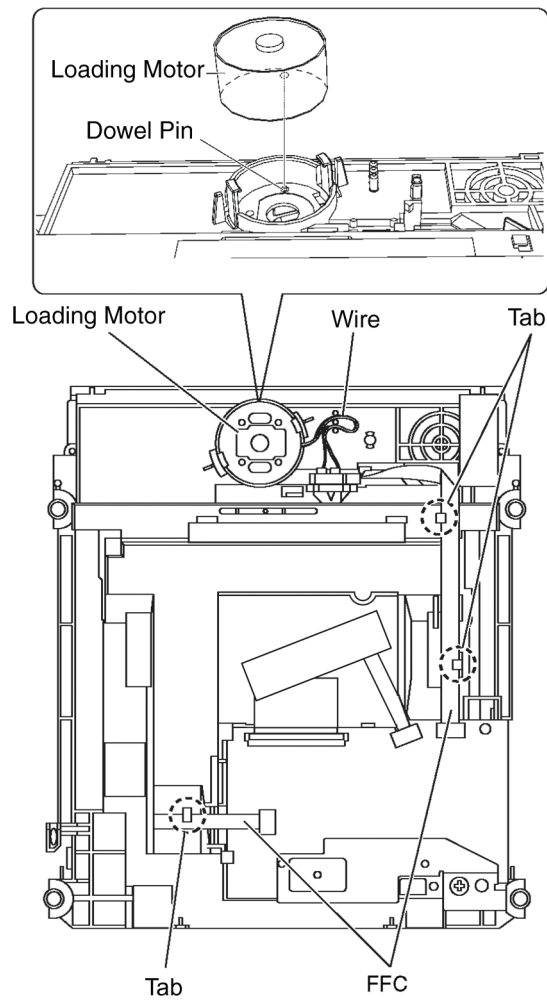

9.12.6. Grease

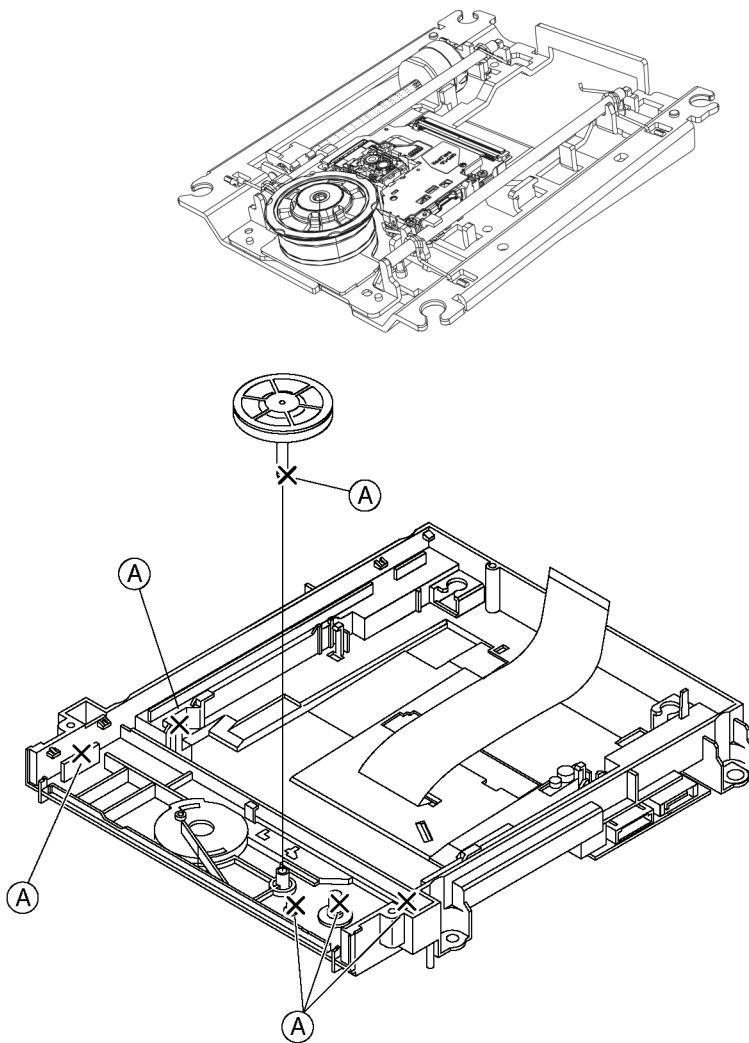
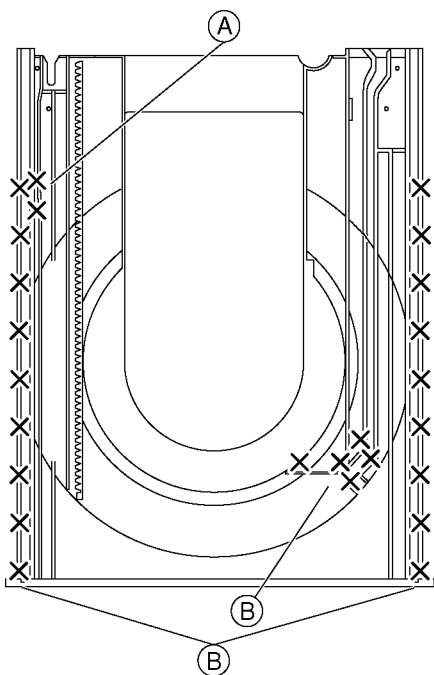
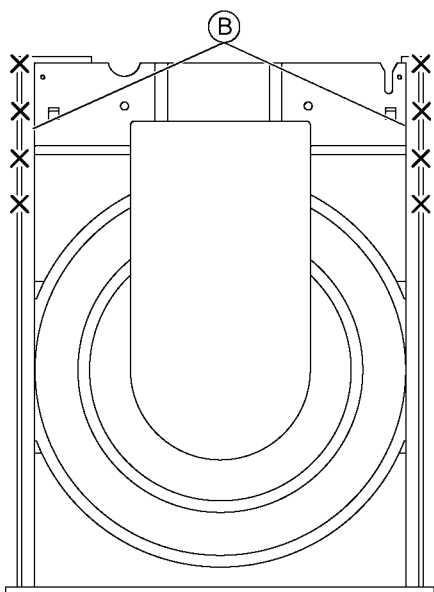
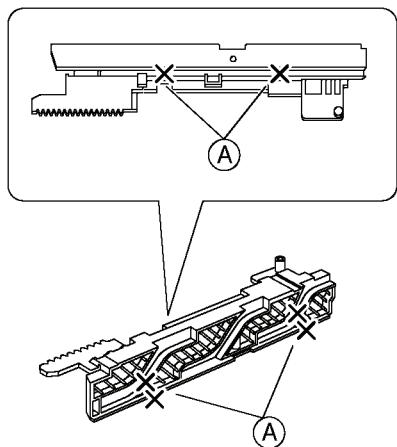

LUBRICATION POINTS

When the above parts are replaced, apply the recommended lubricants or adhesive for better maintenance of the unit.

Mark	Kind of lubricant	Part No.
Ⓐ	Grease	RFKZ0484
Ⓑ	Hanarl	RFKZ0441

9.12.7. How to Clean the Lens of Optical Pick-UP

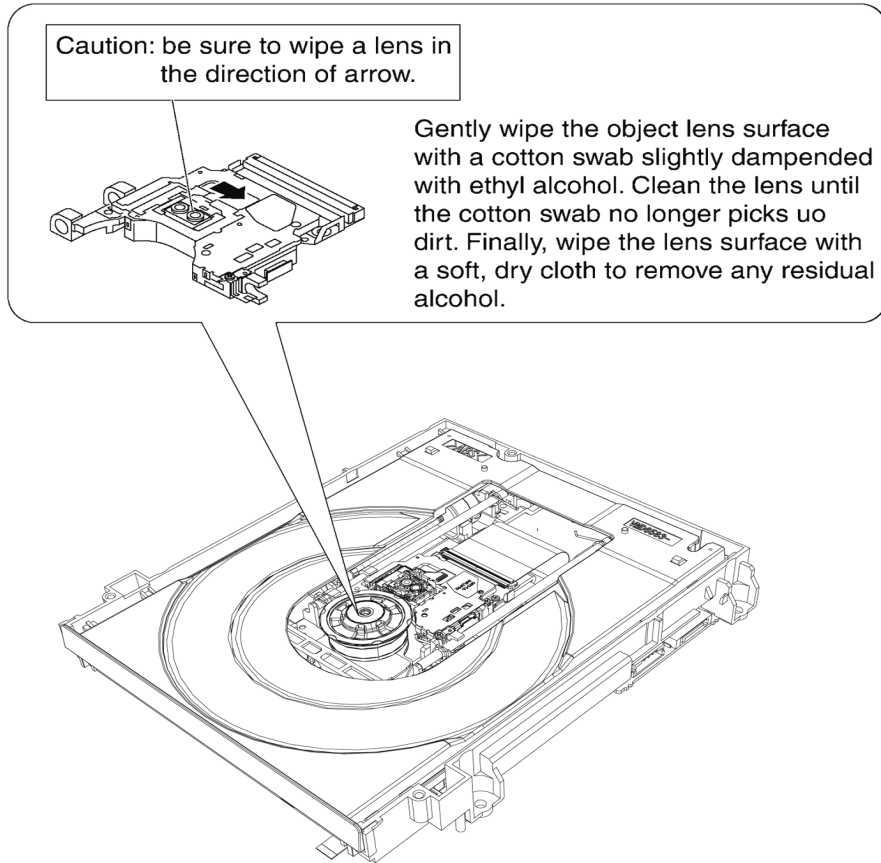

9.12.8. Service hint

If a defective phenomenon is "NO READ", please try to clean TT (turn table) in the drive in according to the following procedure.

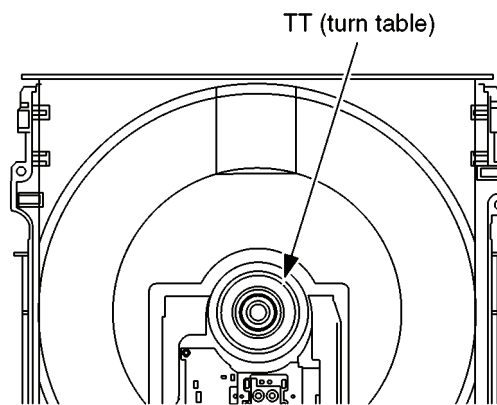

1. Blow off dust on TT by a blower. (Air must not blow to it strongly.)

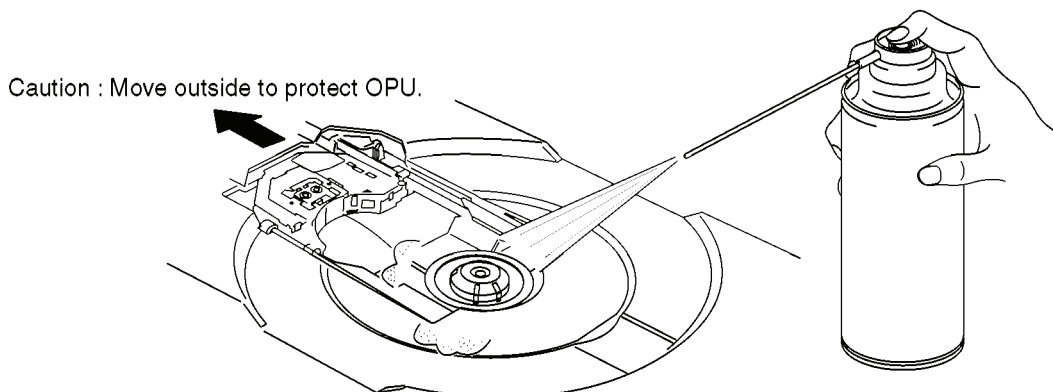

2. Apply one drop of ethyl alcohol or isopropyl alcohol on a clean cotton swab.
(Always use a fresh cotton swab free from any additive or chemical.)

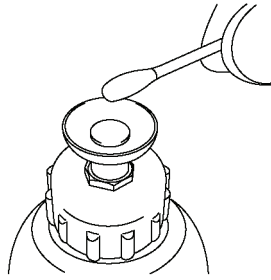

3. Lightly put the cotton swab on TT, and wipe it by turning by your finger.
(Don't touch the surface of TT when you turn it.)

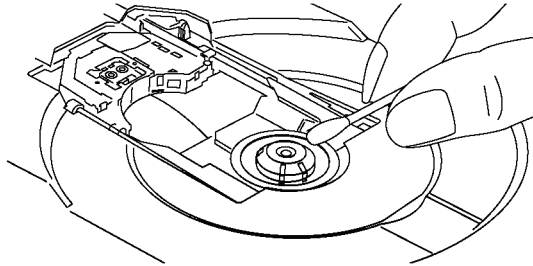

10 Measurements and Adjustments

10.1. Service Positions

NOTE:

For description of the disassembling procedure, see the section 9.

10.1.1. Checking and Repairing of HDD

1. Top Ornament Ass'y
 Remove 3 screws to remove Top Ornament Ass'y.

2. Top Case
 Remove 2 screws on side.
 Remove 2 screws on rear, remove Top Case.

3. Front Panel Ass'y
 Unlock 6 tabs turn and remove Front Panel Ass'y.

4. Wi-Fi Module, HDD and HDD BRIDGE P.C.B.
 Disconnect the two connectors of WLAN Cable.
 Remove 2 Screws to remove Wi-Fi Module and WI-FI BRACKET.
 Remove 1 Screw to remove Wi-Fi Module.
 Remove 3 Screws and disconnect the connector of HDD BRIDGE P.C.B. to remove HDD with HDD bracket.
 Remove 4 Screws to remove HDD from HDD Bracket.
 Pull up HDD BRIDGE P.C.B..
 Connect the Wi-Fi Module to the Digital P.C.B. with WLAN Cable.
 Assemble Front Panel.
 Connect the HDD BRIDGE P.C.B. to the Digital P.C.B..
 Assemble the HDD to the HDD Bracket.

Connect Extension Cables shown below.
 Between HDD and Digital P.C.B. (RFKZ0577) 15 Pin.
 Between HDD and Digital P.C.B. (RFKZ0455) 7 Pin.

Caution :
 1. Red wire should be connected to pin 1.

The diagram illustrates the internal layout of the device's main P.C.B. and the connection of the HDD assembly. Key components labeled include the D-AUDIO P.C.B., DIGITAL P.C.B., and MAIN P.C.B. A WIFI Module is shown on the left, mounted on an INSULATION BOARD. The HDD assembly, consisting of an HDD Bracket and the HDD itself, is shown at the bottom, also on an INSULATION BOARD. Two extension cables are shown connecting the HDD assembly to the DIGITAL P.C.B.: a 7-pin cable (RFKZ0455) and a 15-pin cable (RFKZ0577). A caution note specifies that the red wire of the 15-pin cable must be connected to pin 1.

10.1.2. Checking and Repairing of BD Drive

1. Top Ornament Ass'y

Remove 3 screws to remove Top Ornament Ass'y.

2. Top Case

Remove 2 screws on side.

Remove 2 screws on rear, remove Top Case.

3. BD Drive

Disconnect the connector of DRIVE FFC .

Remove 4 Screws to remove BD Drive.

Connect Extension Cables shown below.

Between BD Drive and Digital P.C.B. (SUKZ000007)18 Pin.

Caution :

1. Red wire should be connected to pin 1.

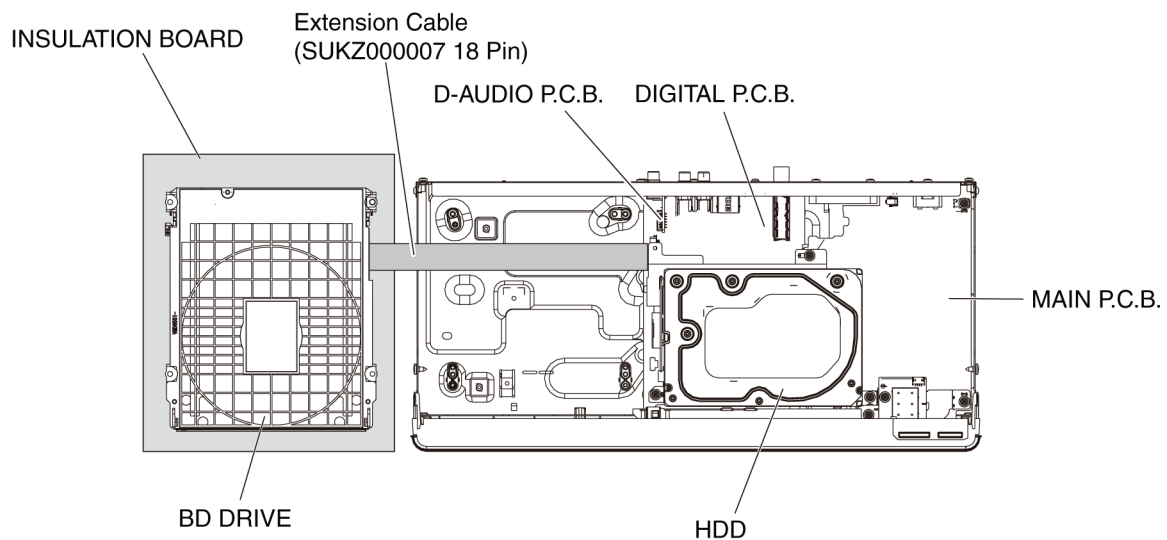

10.1.3. Checking and Repairing of Main P.C.B.

1. Top Ornament Ass'y
 Remove 3 screws to remove Top Ornament Ass'y.
2. Top Case
 Remove 2 screws on side.
 Remove 2 screws on rear, remove Top Case.
3. Front Panel Ass'y
 Unlock 6 tabs turn and remove Front Panel Ass'y.
4. Wi-Fi Module, HDD and HDD BRIDGE P.C.B.
 Disconnect the two connectors of WLAN Cable.
 Remove 2 Screws to remove Wi-Fi Module and WI-FI BRACKET.
 Remove 1 Screw to remove Wi-Fi Module.
 Remove 3 Screws and disconnect the connector of HDD BRIDGE P.C.B. to remove HDD with HDD bracket.
 Remove 4 Screws to remove HDD from HDD Bracket.
 Pull up HDD BRIDGE P.C.B..
5. Rear Panel and Fan Motor
 Disconnect Fan connector
 Remove 7 Screws (two for HDMI and Tuner) to remove the Rear Panel with Fan.
 Remove 2 Screws to remove the Fan.
6. Main P.C.B.
 Disconnect 1 connector.
 Remove 1 Screw to remove Main P.C.B..

Connect the Wi-Fi Module to the Digital P.C.B. with WLAN Cable.
 Connect the Front P.C.B. to the Main P.C.B..
 Connect Fan connector to Digital P.C.B.
 Connect the HDD BRIDGE P.C.B. to the Digital P.C.B..
 Assemble the HDD to the HDD Bracket.

Connect Extension Cables shown below.
 Between Main P.C.B. and Digital P.C.B. (RFKZ0216) 23 Pin.
 Between HDD and Digital P.C.B. (RFKZ0577) 15 Pin.
 Between HDD and Digital P.C.B. (RFKZ0455) 7 Pin.

Caution :
 1. Red wire should be connected to pin 1.

The diagram illustrates the internal layout of the device. Key components and their connections are labeled as follows:

- Extension Cable (RFKZ0577 15Pin):** Connects the Digital P.C.B. to the HDD Bracket.
- Extension Cable (RFKZ0216 23Pin):** Connects the Main P.C.B. to the Digital P.C.B.
- Extension Cable (RFKZ0455 7Pin):** Connects the Digital P.C.B. to the HDD Bracket.
- Other components:** D-AUDIO P.C.B., DIGITAL P.C.B., FAN, BD DRIVE, Wi-Fi Module, INSULATION BOARD, HDD Bracket, HDD, Front P.C.B., and MAIN P.C.B.

10.1.4. Checking and Repairing of Digital P.C.B.

1. Top Ornament Ass'y

Remove 3 screws to remove Top Ornament Ass'y.

2. Top Case

Remove 2 screws on side.

Remove 2 screws on rear, remove Top Case.

3. Front Panel Ass'y

Unlock 6 tabs turn and remove Front Panel Ass'y.

4. Wi-Fi Module, HDD and HDD BRIDGE P.C.B.

Disconnect the two connectors of WLAN Cable.

Remove 2 Screws to remove Wi-Fi Module and WI-FI BRACKET.

Remove 1 Screw to remove Wi-Fi Module.

Remove 3 Screws and disconnect the connector of HDD BRIDGE P.C.B. to remove HDD with HDD bracket.

Remove 4 Screws to remove HDD from HDD Bracket.

Pull up HDD BRIDGE P.C.B..

5. Rear Panel and Fan Motor

Disconnect Fan connector.

Remove 7 Screws (two for HDMI and Tuner) to remove the Rear Panel with Fan.

Remove 2 Screws to remove the Fan.

6. D-AUDIO P.C.B.

Pull up D-AUDIO P.C.B..

7. Digital P.C.B.

Disconnect 1 connector.

Remove 3 Screws to remove Digital P.C.B..

Connect the Wi-Fi Module to the Digital P.C.B. with WLAN Cable.
Assemble Front Panel.
Connect Fan connector to Digital P.C.B.
Connect the HDD BRIDGE P.C.B. to the Digital P.C.B..
Connect the D-AUDIO P.C.B. to the Digital P.C.B..
Assemble the HDD to the HDD Bracket.

Connect Extension Cables shown below.

Between Main P.C.B. and Digital P.C.B. (RFKZ0216) 23 Pin.

Between HDD and Digital P.C.B. (RFKZ0577) 15 Pin.

Between HDD and Digital P.C.B. (RFKZ0455) 7 Pin.

Between Digital P.C.B. and BD Drive (SUKZ000007) 18 Pin.

Caution :

1. Red wire should be connected to pin 1.

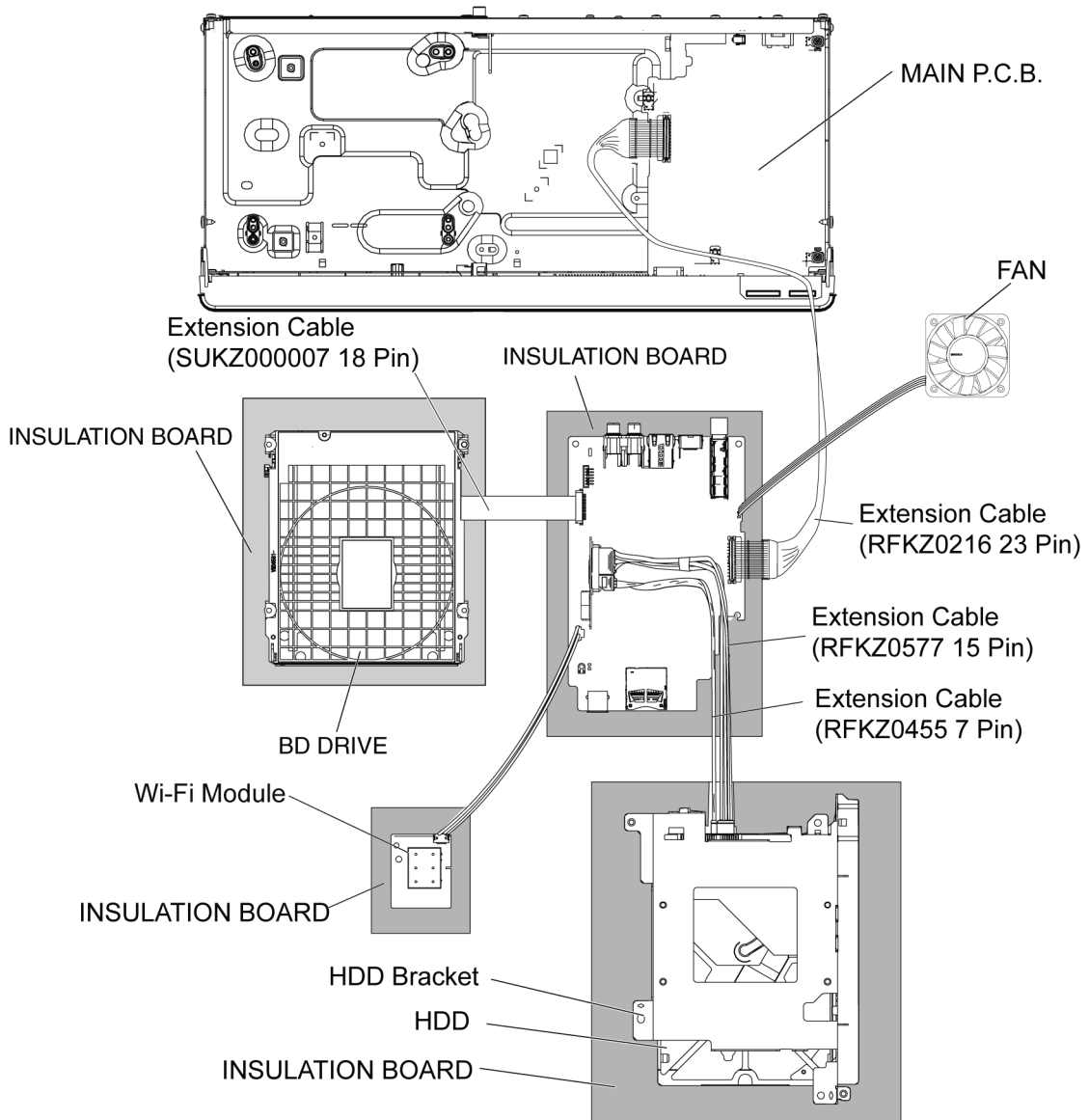

10.2. Caution for Replacing Parts

10.2.1. Items that should be done after replacing parts

✓:Necessary —:Unnecessary

Items that Should be done	Main Firm update	HDD Format
Replacing Parts		
Digital P.C.B.	✓	—
D-Audio P.C.B. (IC9501: EEPROM)	—	✓
HDD	—	✓

10.2.2. Notice after replacing Digital P.C.B. or BD Drive

Formatting the HDD is unnecessary after replacing Digital P.C.B. or BD Drive.

[TM AV1] is displayed, once power OFF, and power ON again.

10.3. Standard Inspection Specifications after Making Repairs

After making repairs, we recommend performing the following inspection, to check normal operation.

No.	Procedure	Item to Check
1	Turn on the power, and confirm items pointed out.	Items pointed out should reappear.
2	Insert RAM disc.	The Panasonic RAM disc should be recognized.
3	Enter the EE (TU IN / AV IN - AV OUT) mode.	No abnormality should be seen in the picture, sound or operation.
4	Model with the HDD: Perform self-recording and playback for one minute using the HDD.	No abnormality should be seen in the picture, sound or operation.
5	Perform copy a program to disc and playback for one minute using the BD-RE (V2.0) and RAM discs.	No abnormality should be seen in the picture, sound or operation. *Panasonic BD-RE (V2.0) and DVD-RAM discs should be used when copying and playback.
6	If a problem is caused by a VCD, DVD-R, DVD-Video, Audio-CD, or MP3, playback the test disc.	No abnormality should be seen in the picture, sound or operation.
7	Models with SD Card Slot or DV Input Jack or USB Input Jack: In case of that the trouble is caused by SD card and/or DV terminal and / or USB terminal.	Models with SD Card or DV Input Jack; 1) SD Card: Check to be able to display and copy the picture. 2) DV terminal: Check to be able to record from DVC. 3) USB terminal: Check to be able to display and copy the picture.
8	After checking and making repairs, upgrade the firmware to the latest version.	Do not turn the power off until writing is complete (The tray automatically opens when writing is complete.). "NoUPDATE" message indicates that updating the version is not necessary since the version is the latest or the same one.
9	Transfer [9][9] in the service mode setting, and initialize the service settings (return various settings and error information to their default values. The laser time is not included in this initialization).	Make sure that [CLR] appears in the LCD display. After checking it, turn the power off.

Use the following checklist to establish the judgement criteria for the picture and sound.

Item	Contents	Check	Item	Contents	Check
Picture	Block noise		Sound	Distorted sound	
	Crosscut noise			Noise (static, background noise, etc.)	
	Dot noise			The sound level is too low.	
	Picture disruption			The sound level is too high.	
	Not bright enough			The sound level changes.	
	Too bright				
	Flickering color				
Color fading					

11 Block Diagram

11.1. Power Supply Block Diagram

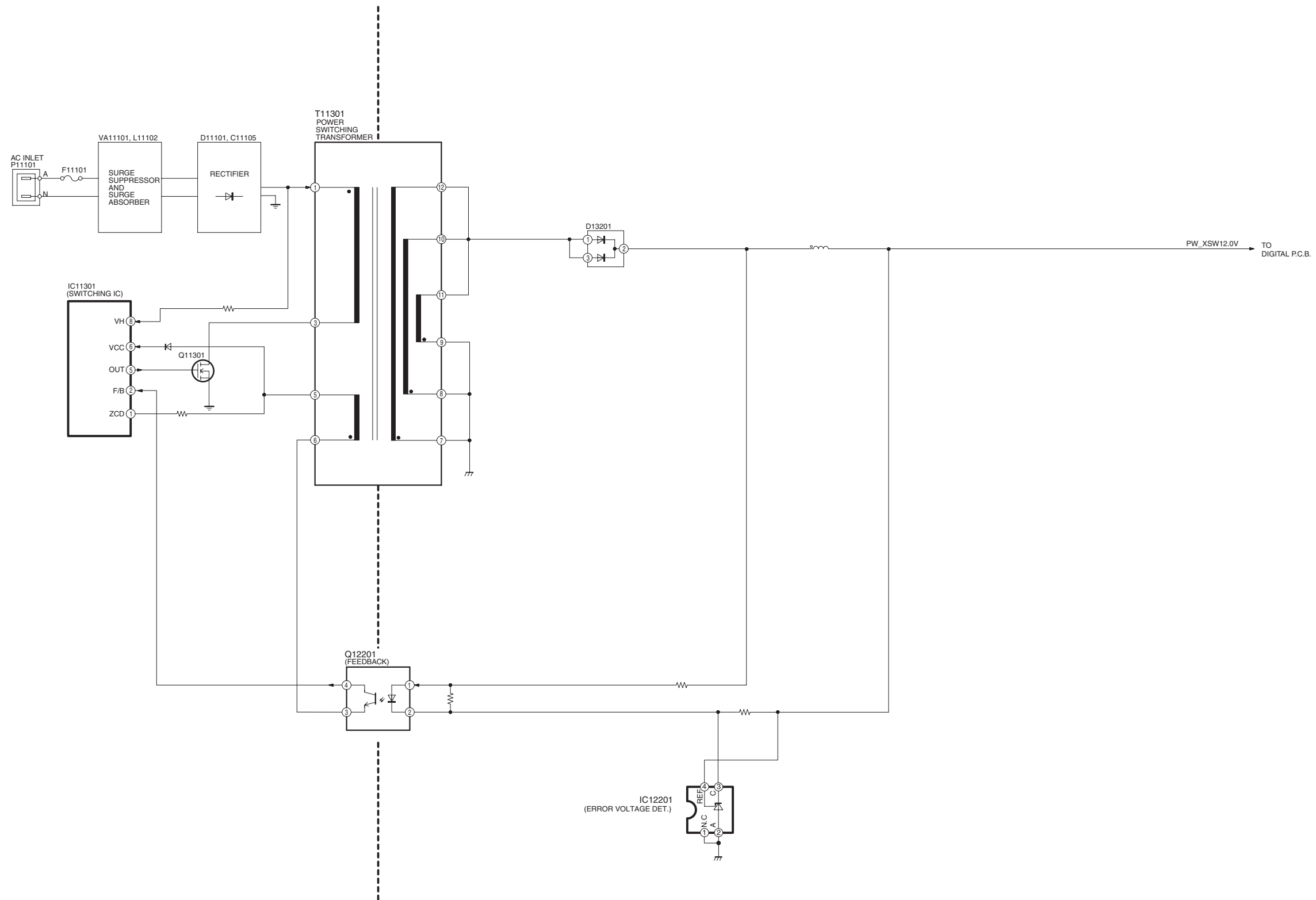

11.2. Analog Audio and Video Block Diagram

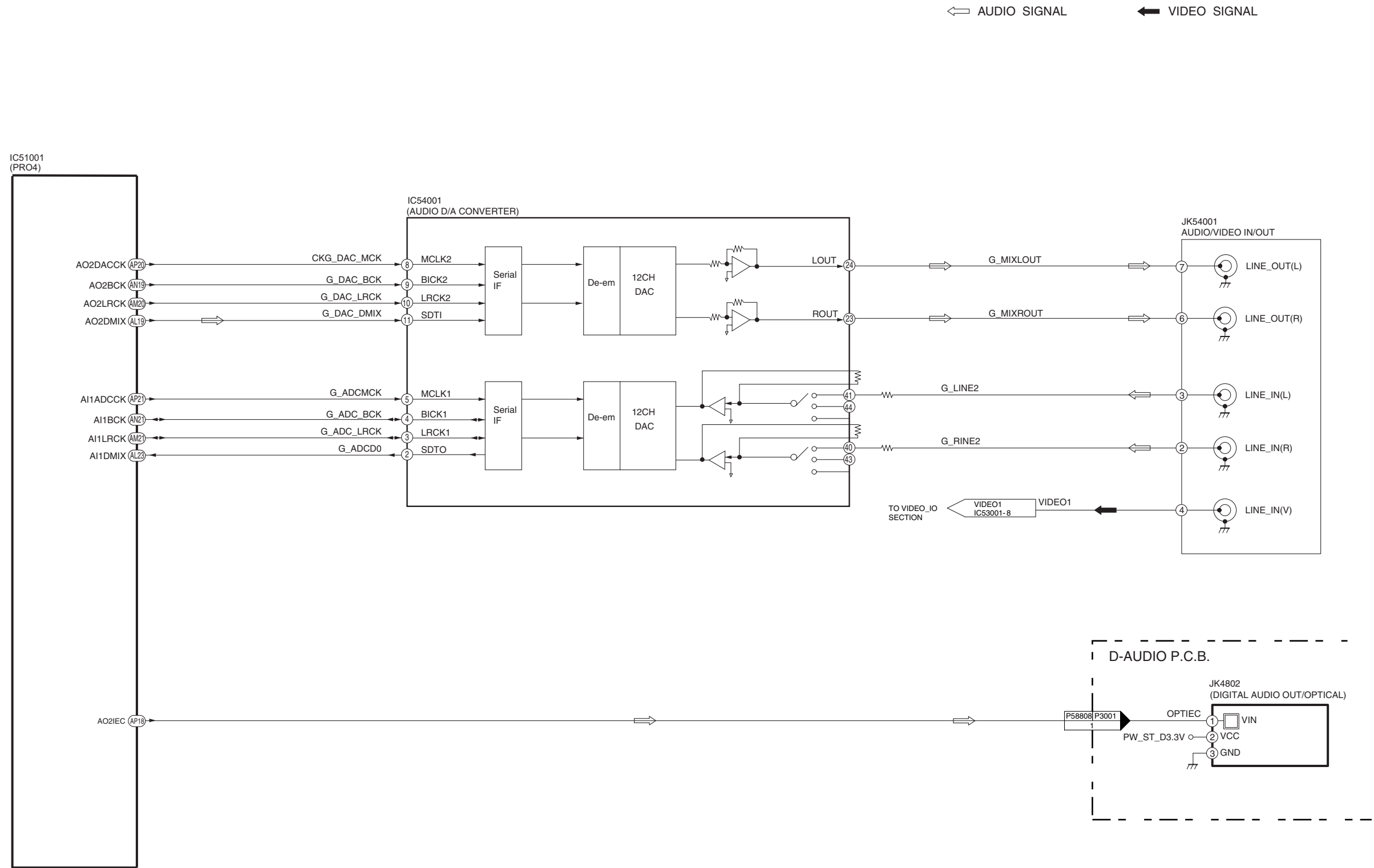

DMR-BWT955GL
AUDIO/VIDEO BLOCK DIAGRAM

11.3. Analog Timer Block Diagram

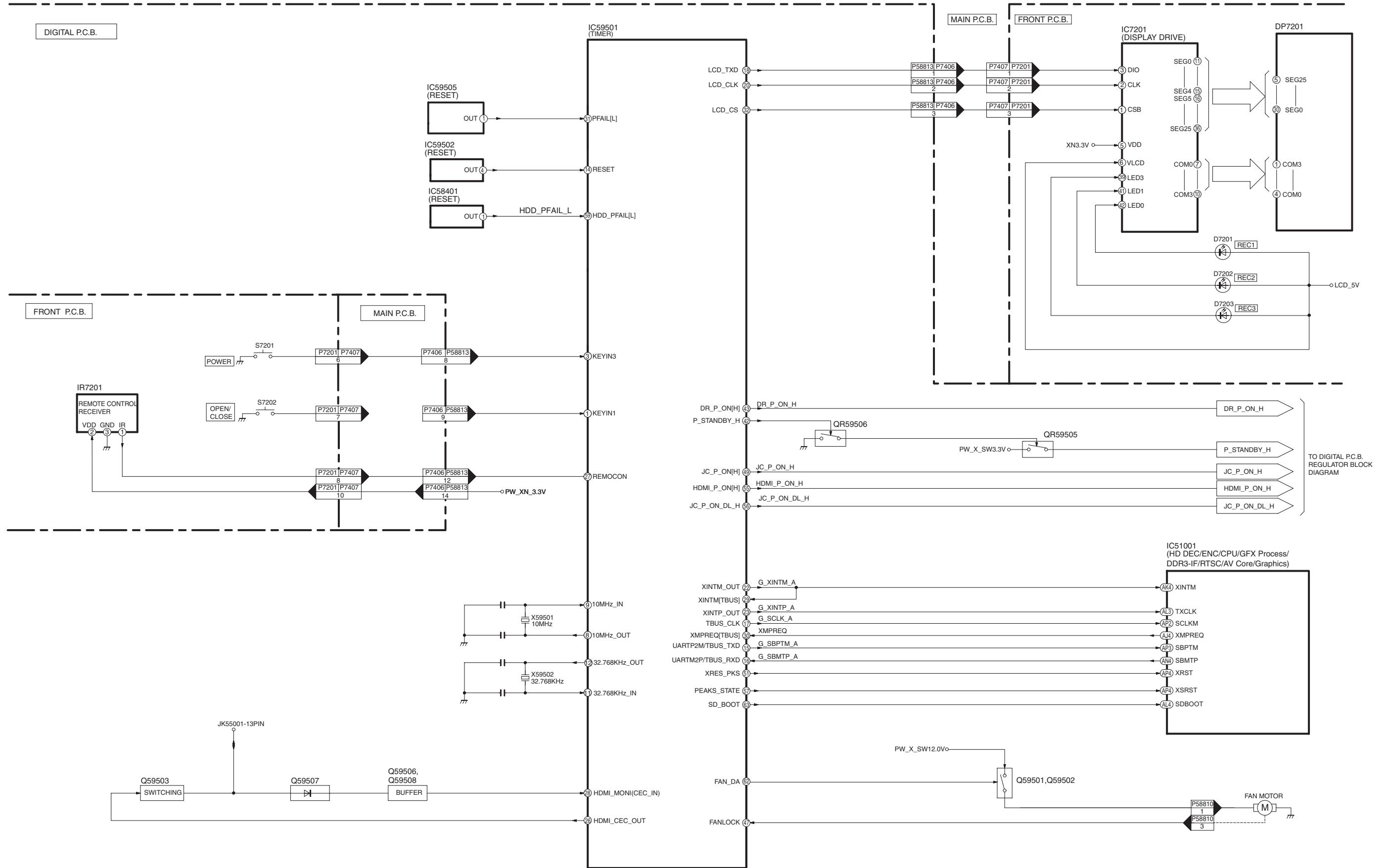

DMR-BWT955GL
Timer Block Diagram

11.4. Digital P.C.B. Block Diagram (1/2)

- VIDEO REC SIGNAL
- VIDEO EE SIGNAL
- VIDEO PB SIGNAL
- AUDIO REC SIGNAL
- AUDIO EE SIGNAL
- AUDIO PB SIGNAL

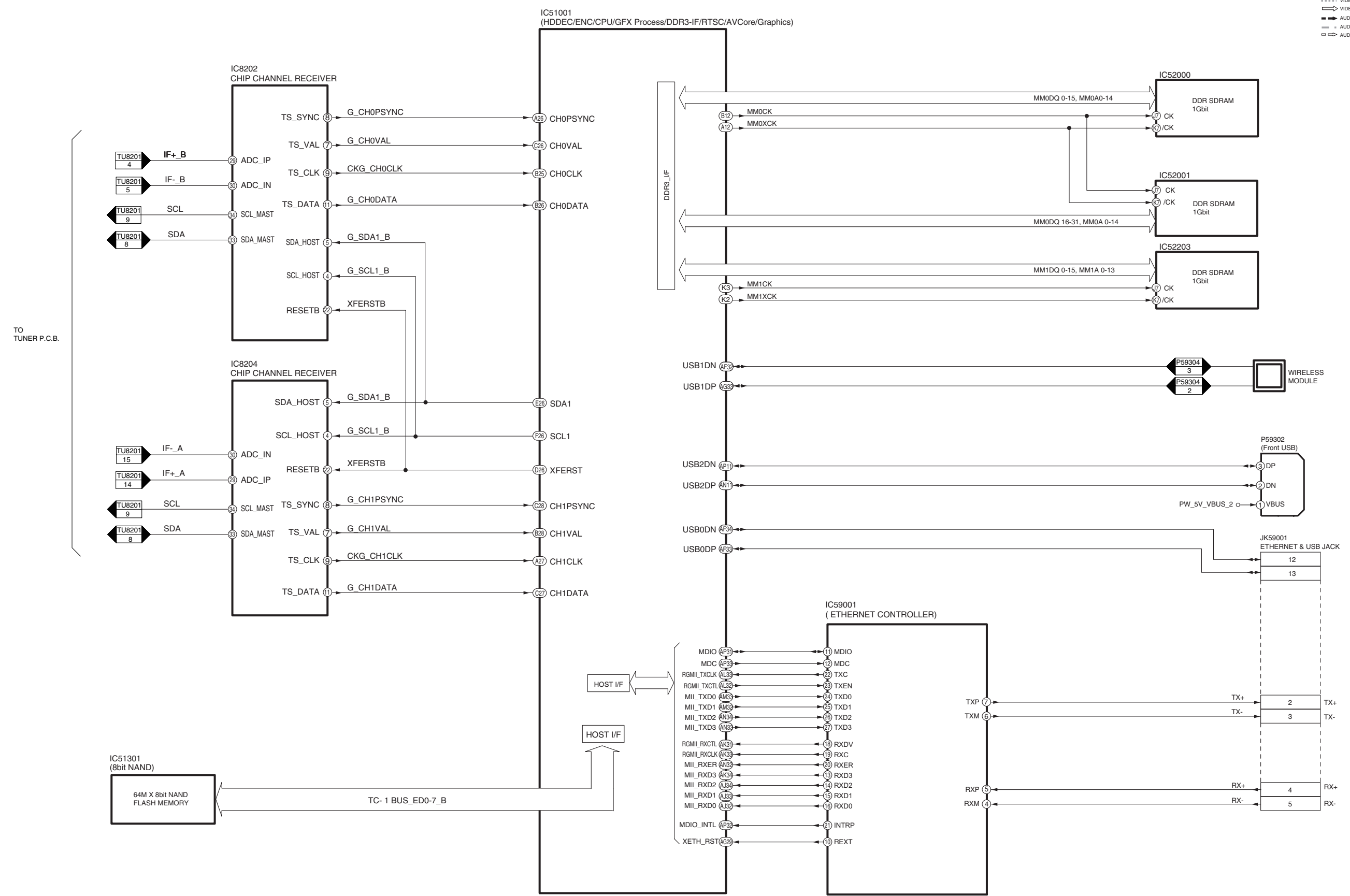

DMR-BWT955GL
DIGITAL BLOCK DIAGRAM(1/2)

11.5. Digital P.C.B. Block Diagram (2/2)

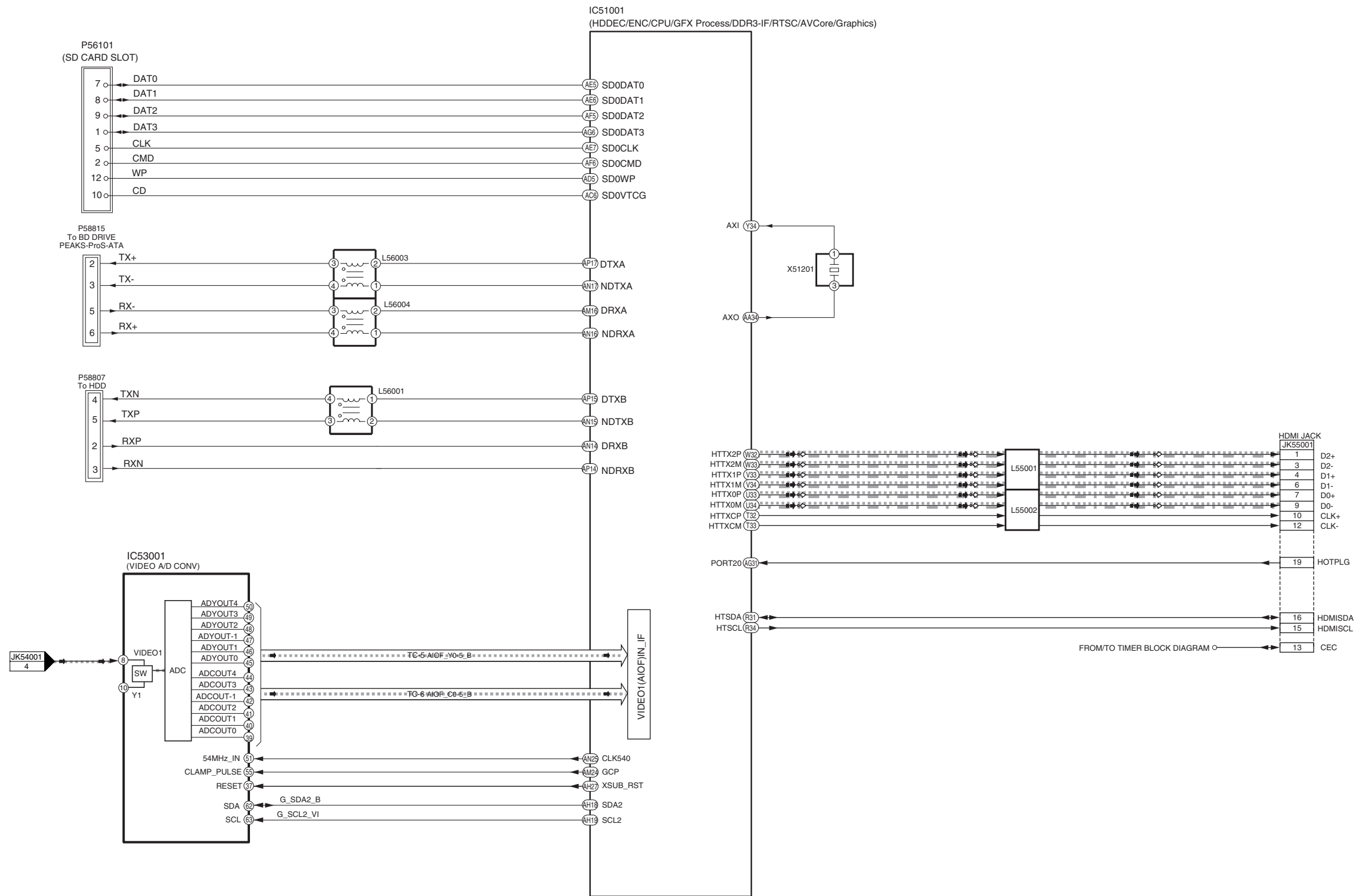

DMR-BWT955GL
DIGITAL BLOCK DIAGRAM(2/2)

11.6. Digital P.C.B. Regulator Block Diagram

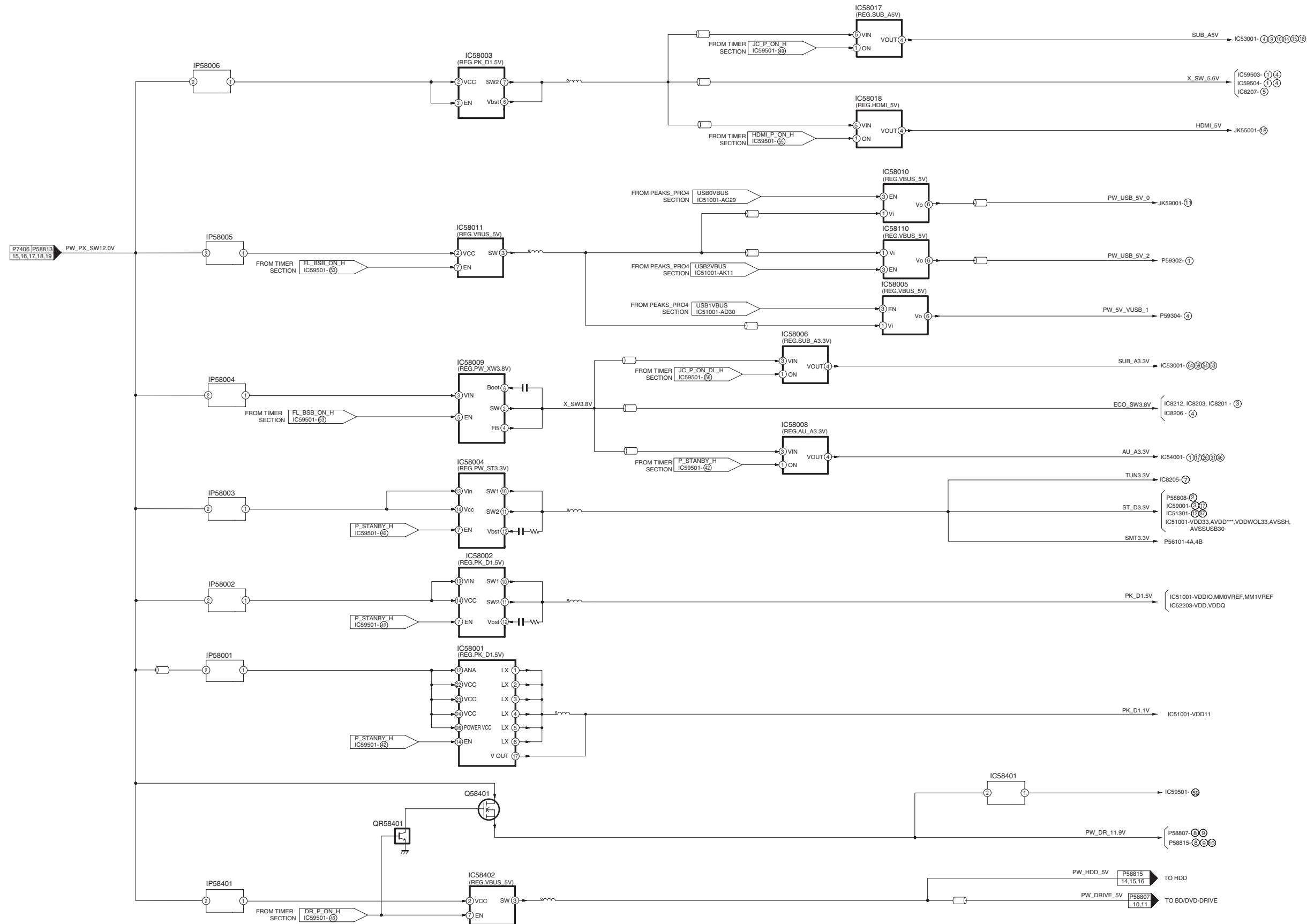

DMR-BWT955GL
Digital P.C.B. Regulator Block Diagram

12 Wiring Connection Diagram

12.1. Interconnection Schematic Diagram

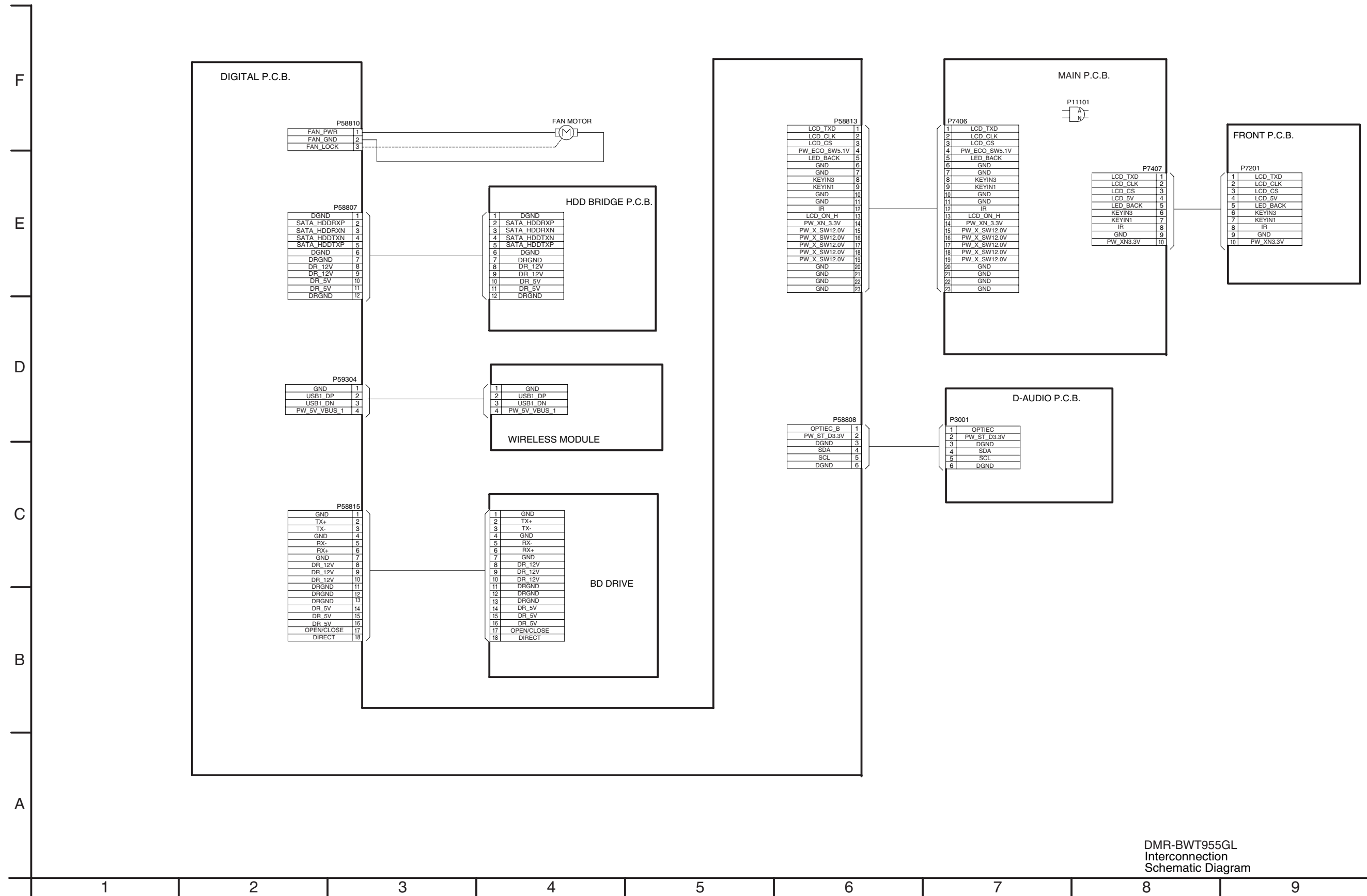

DMR-BWT955GL
Interconnection
Schematic Diagram

IMPORTANT SAFETY NOTICE:

COMPONENTS IDENTIFIED WITH THE MARK ⚠ HAVE THE SPECIAL CHARACTERISTICS FOR SAFETY WHEN REPLACING ANY OF THESE COMPONENTS USE ONLY THE SAME TYPE.

1. Although reference number of the parts is indicated on the P.C.B. drawing and/or schematic diagrams, it is NOT mounted on the P.C.B. when it is displayed with "\$" mark.
2. It is only the "Test Round" and no terminal (Pin) is available on the P.C.B. when the TP (Test Point) indicated as "●" mark.
3. Use the parts number indicated on the Replacement Parts List.
4. Indication on the Schematic diagrams:

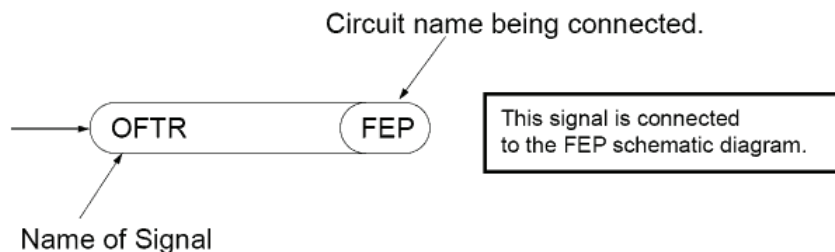

5. It might be taking time for display and/or access of the Schematic Diagrams & P.C.B. having the heavy data volume.
6. The circuit is defined by HOT and COLD indications in the schematic diagram. Please take note to prevent from electric shock.

Model No. : DMR-BWT955GL PART LIST NOTICE

Notes:

*Important safety notice:

Components identified by Δ mark have special characteristics important for safety.

Furthermore, special parts which have purposes of fire-retardant (resistors), high-quality sound (capacitors), low-noise (resistors), etc. are used.

When replacing any of components, be sure to use only manufacture's specified parts shown in the parts list.

*Warning: This product uses a laser diode. Refer to caution statements.

*Capacity values are in microfarads (μ F) unless specified otherwise, P=Pico-farads (pF), F=Farads (F).

*Resistance values are in ohms, unless specified otherwise, 1K=1,000 (OHM), 1M=1,000k (OHM).

*The marking (RTL) indicates the retention time is limited for this item. After the discontinuation of this assembly in production, it will no longer be available.

*"(En)" marks in Remarks indicate languages of instruction manuals. [(En): English]

*All parts are supplied by CHPAVC.

E.S.D. standards for Electrostatically Sensitive Devices, refer to "PREVENTION OF ELECTROSTATIC DISCHARGE (ESD) TO ELECTROSTATICALLY SENSITIVE (ES) DEVICES" section.

Notes:

*Parts indicated with "ADJ" in the Remarks column are necessary to Input Engineering Adjusted Value.

Model No. : DMR-BWT955GL POWER SECTION(MAIN P.C.B.)

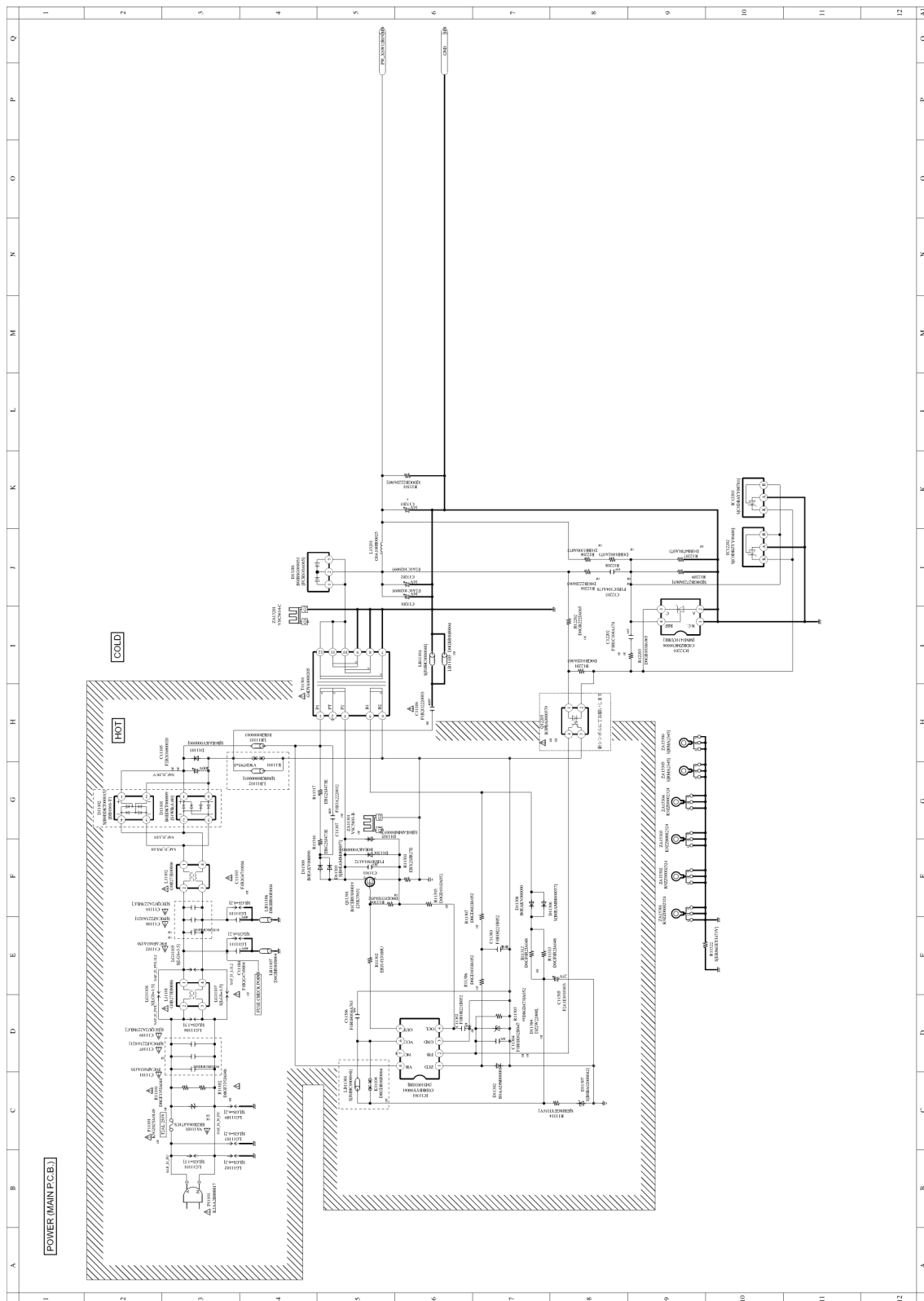

Model No. : DMR-BWT955GL FRONT SECTION(MAIN P.C.B.)

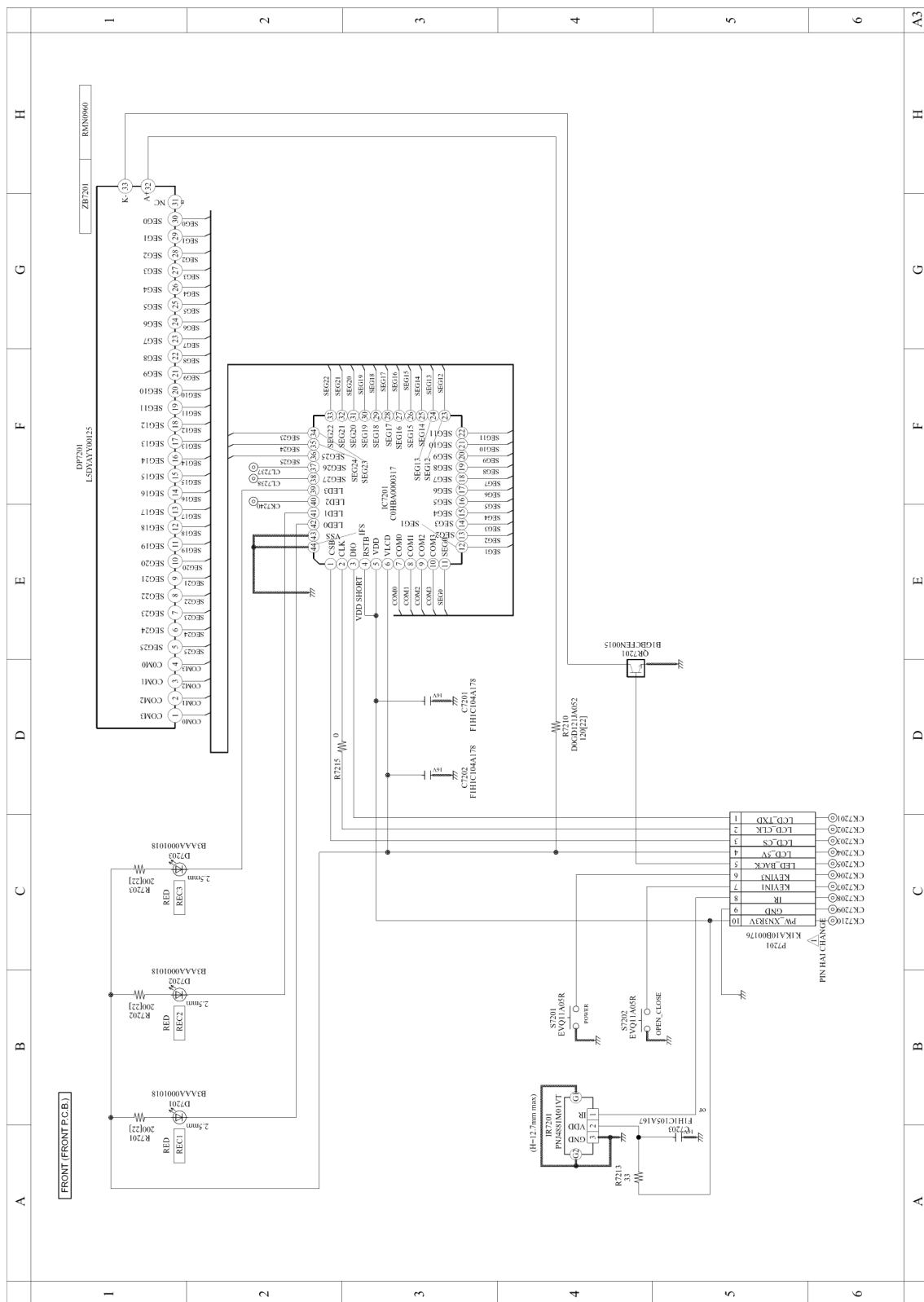

Model No. : DMR-BWT955GL HDD BRIDGE SECTION(HDD BRIDGE P.C.B.)

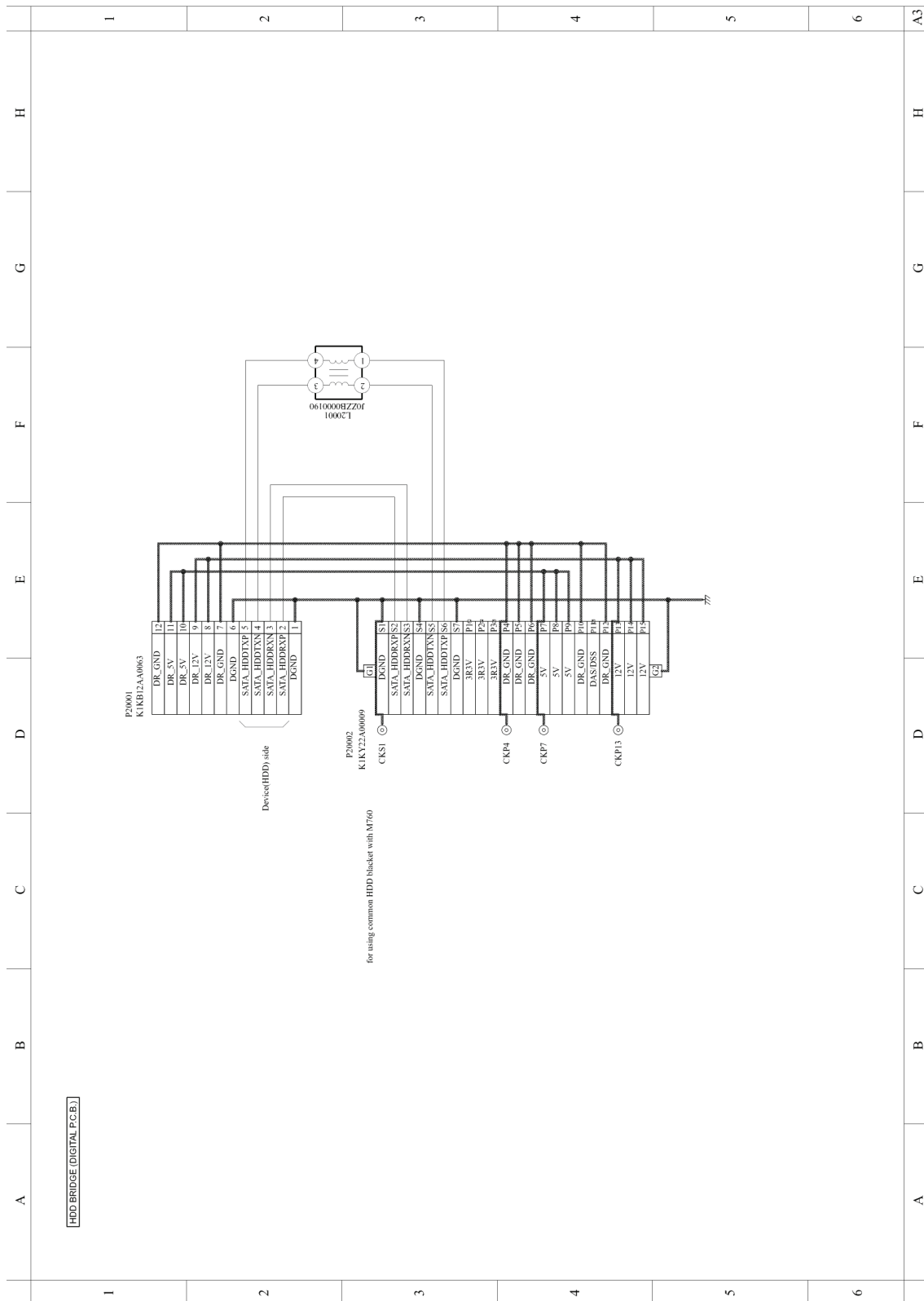

Model No. : DMR-BWT955GL DIGITAL POWER SECTION(DIGITAL P.C.B.)

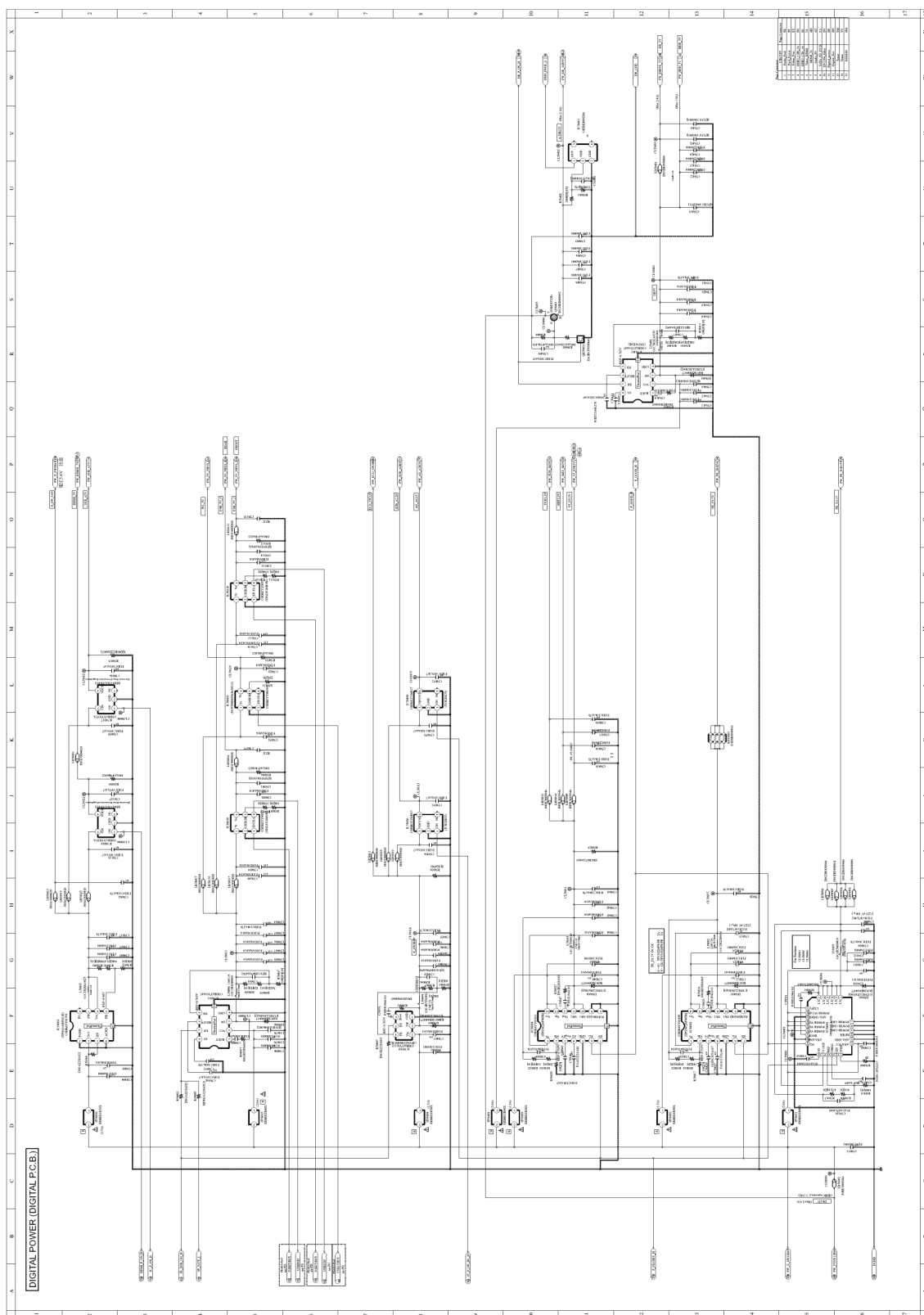

Model No. : DMR-BWT955GL ETHER SECTION(DIGITAL P.C.B.)

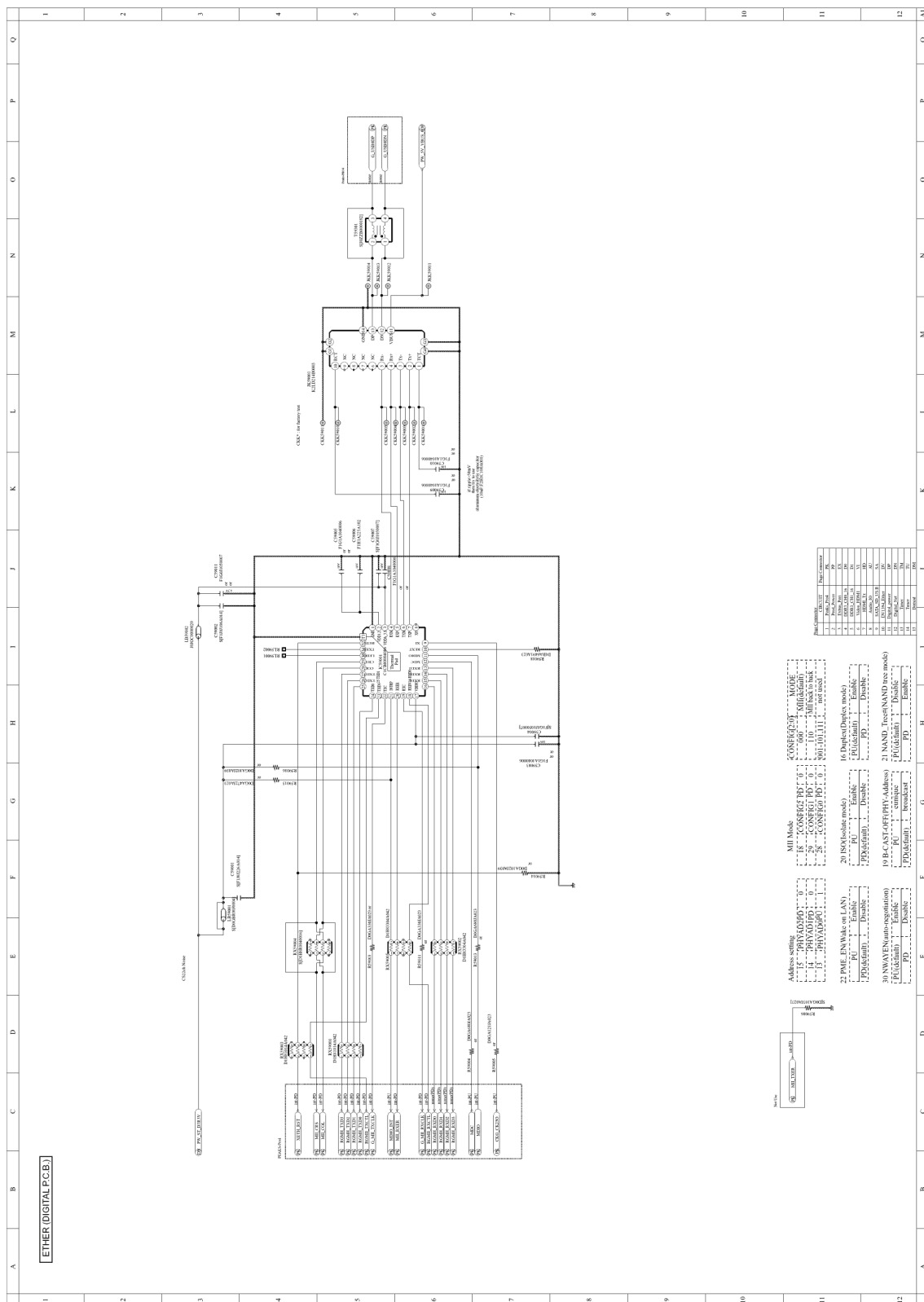

Model No. : DMR-BWT955GL PRO4 POWER SECTION(DIGITAL P.C.B.)

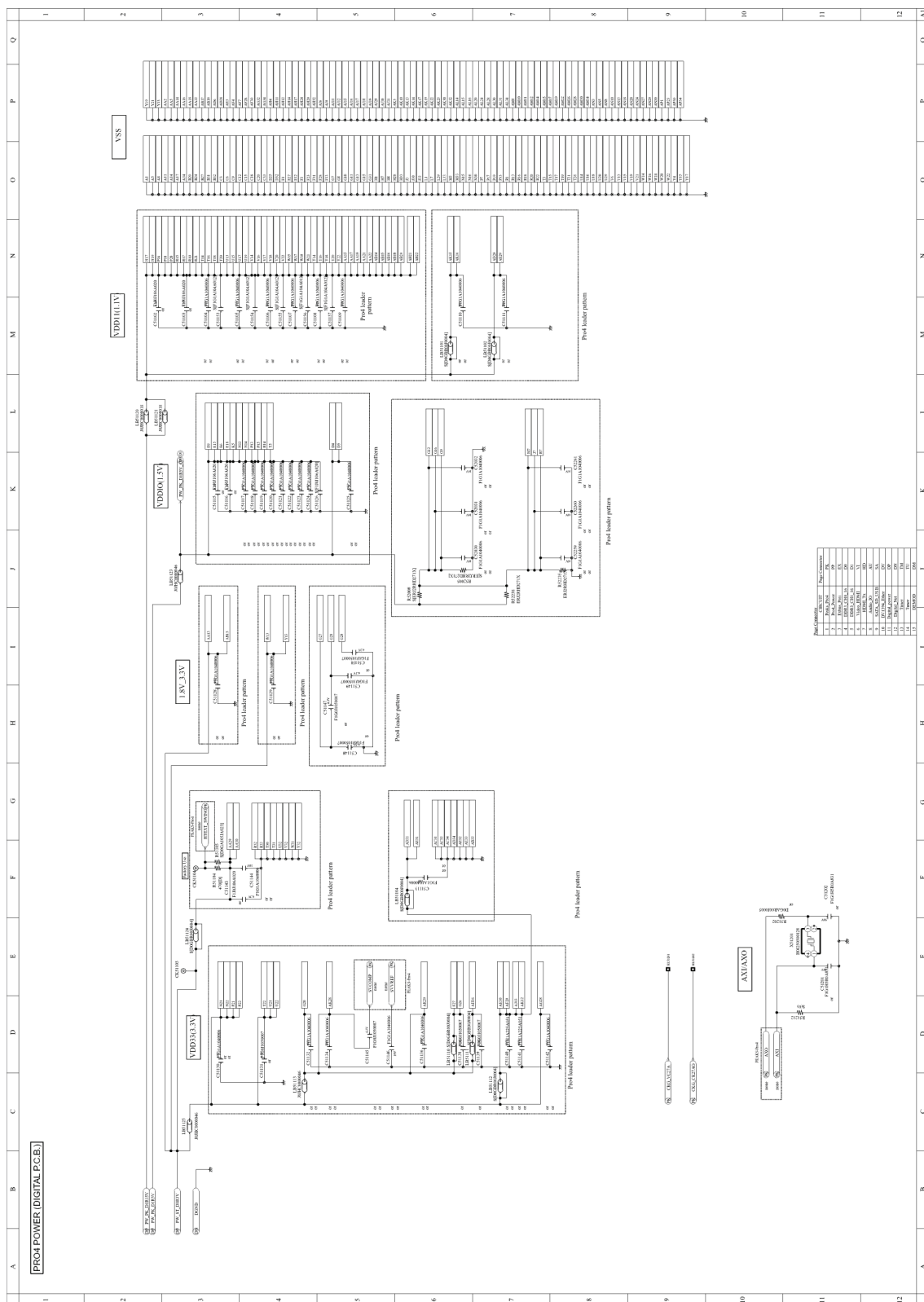

Model No. : DMR-BWT955GL TIMER SECTION(DIGITAL P.C.B.)

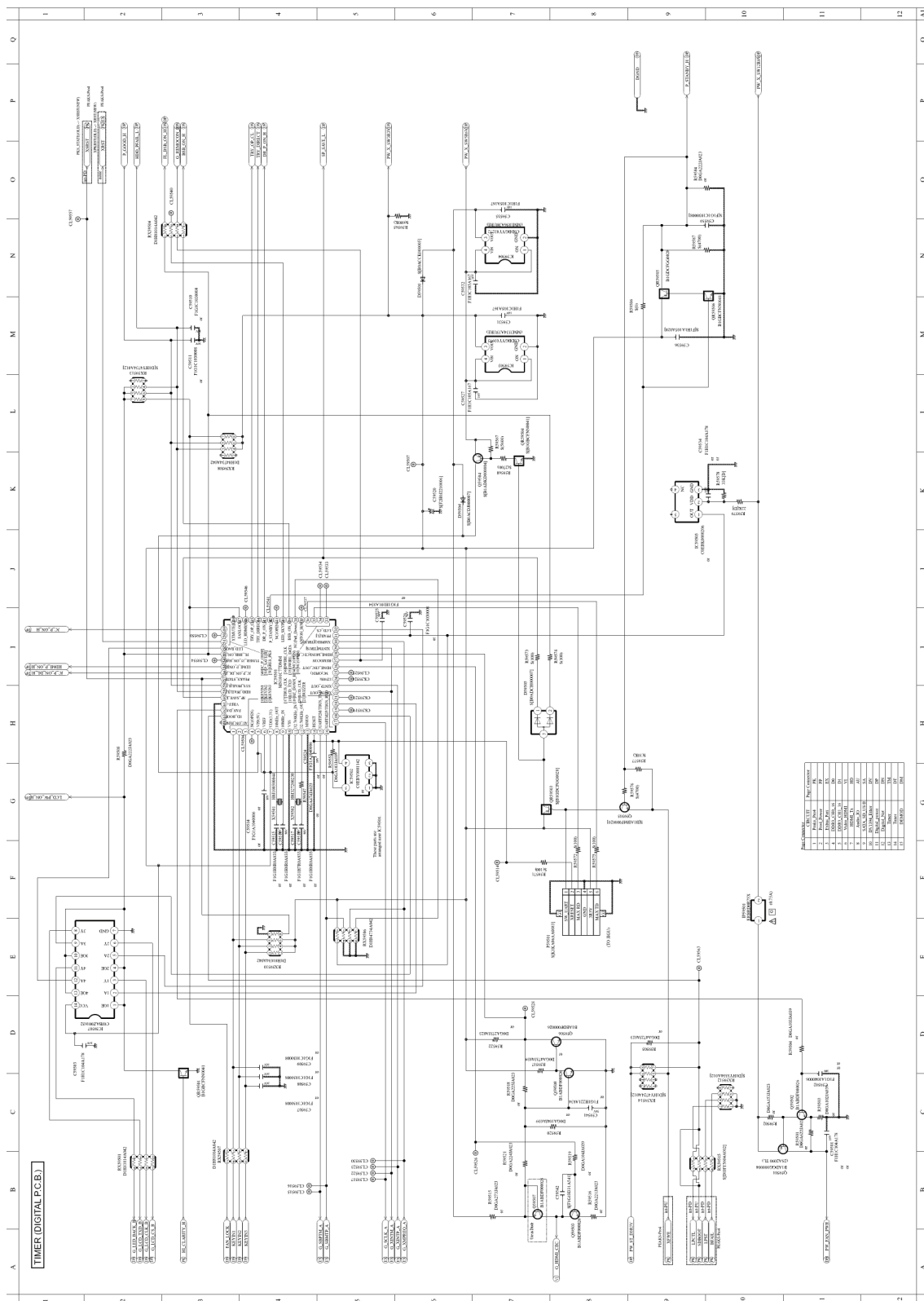

Model No. : DMR-BWT955GL DIGITAL TUNER SECTION(DIGITAL P.C.B.)

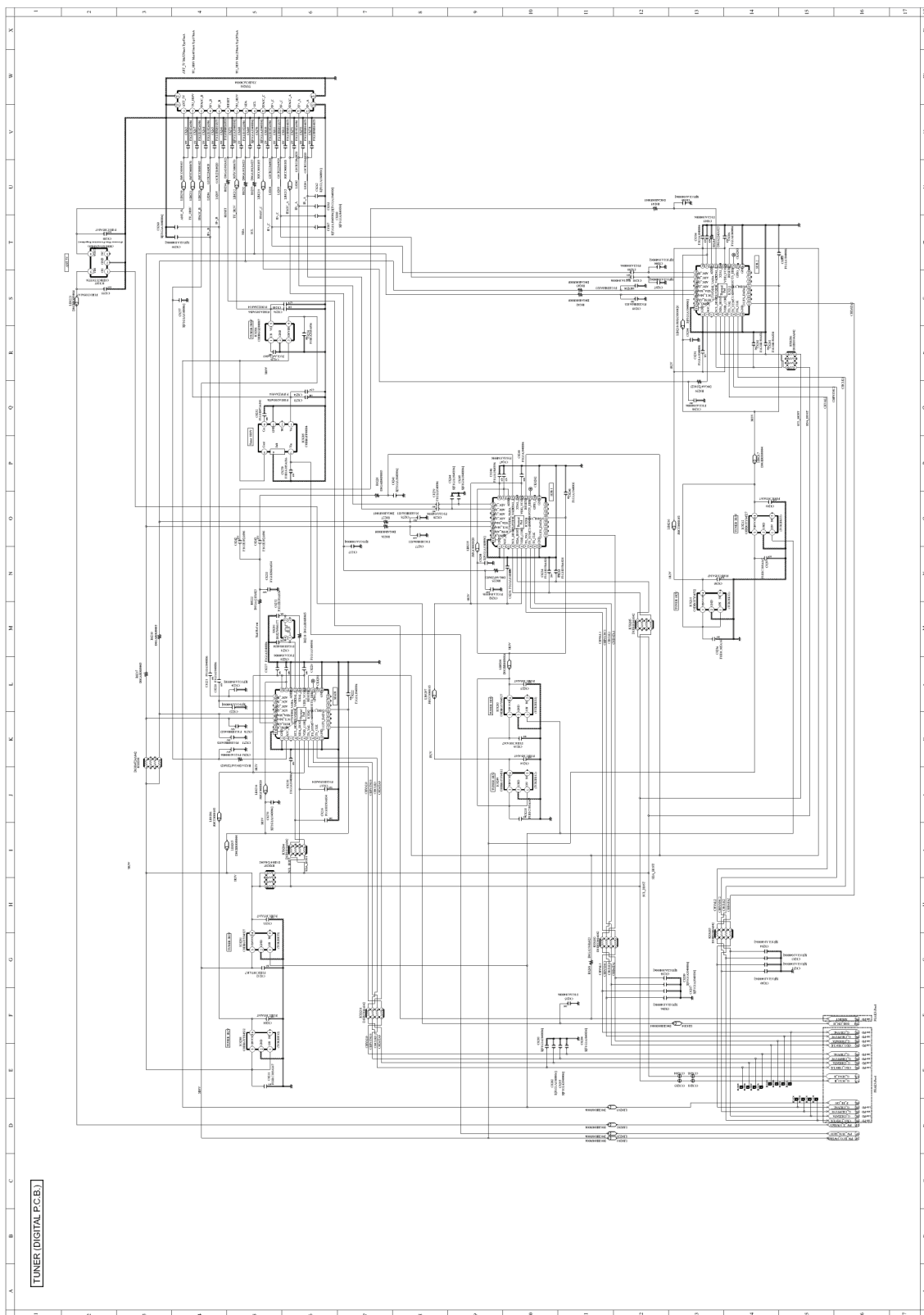

Model No. : DMR-BWT955GL MAIN P.C.B.(COMPONENT SIDE)

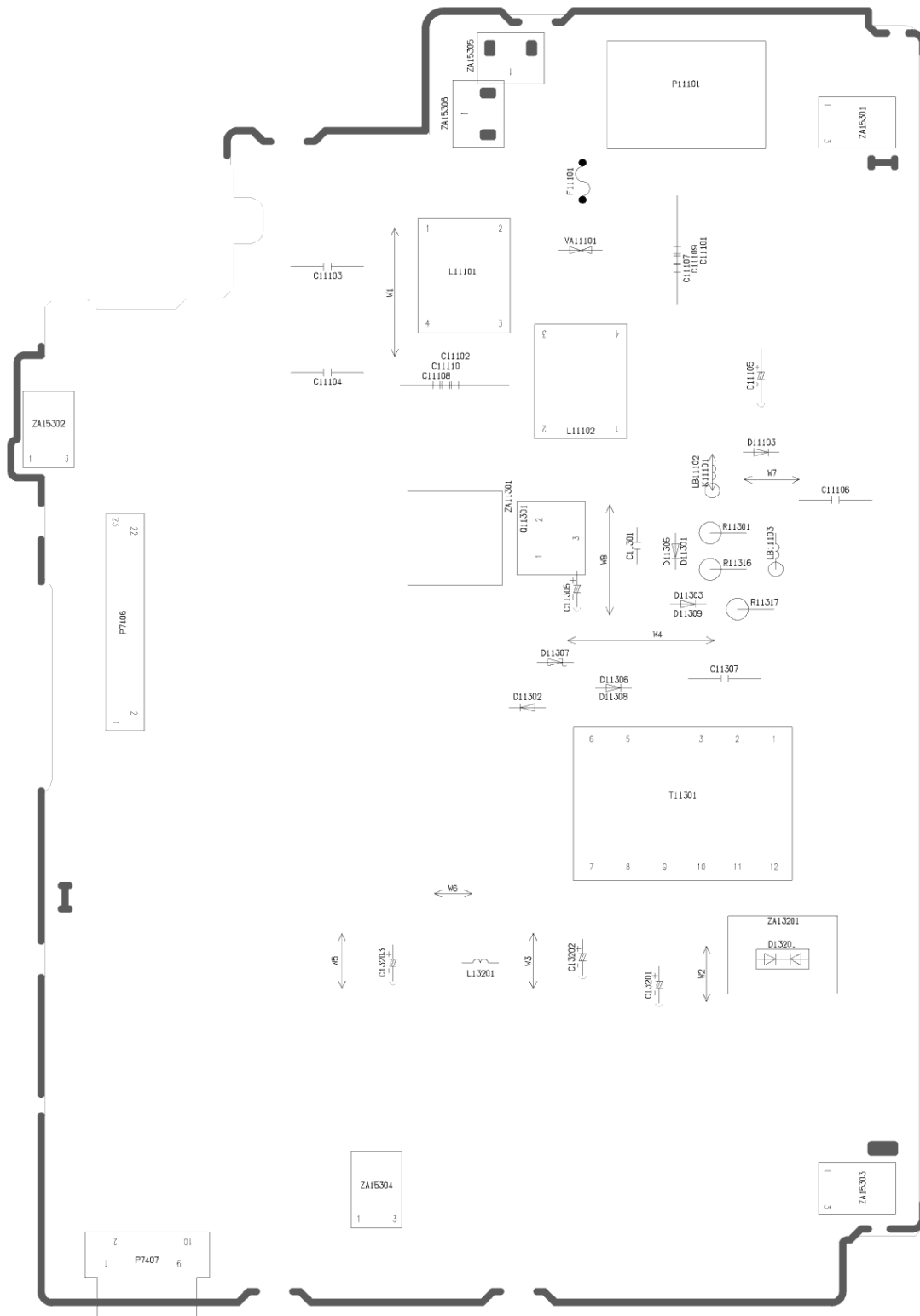

Model No. : DMR-BWT955GL MAIN P.C.B.(FOIL SIDE)

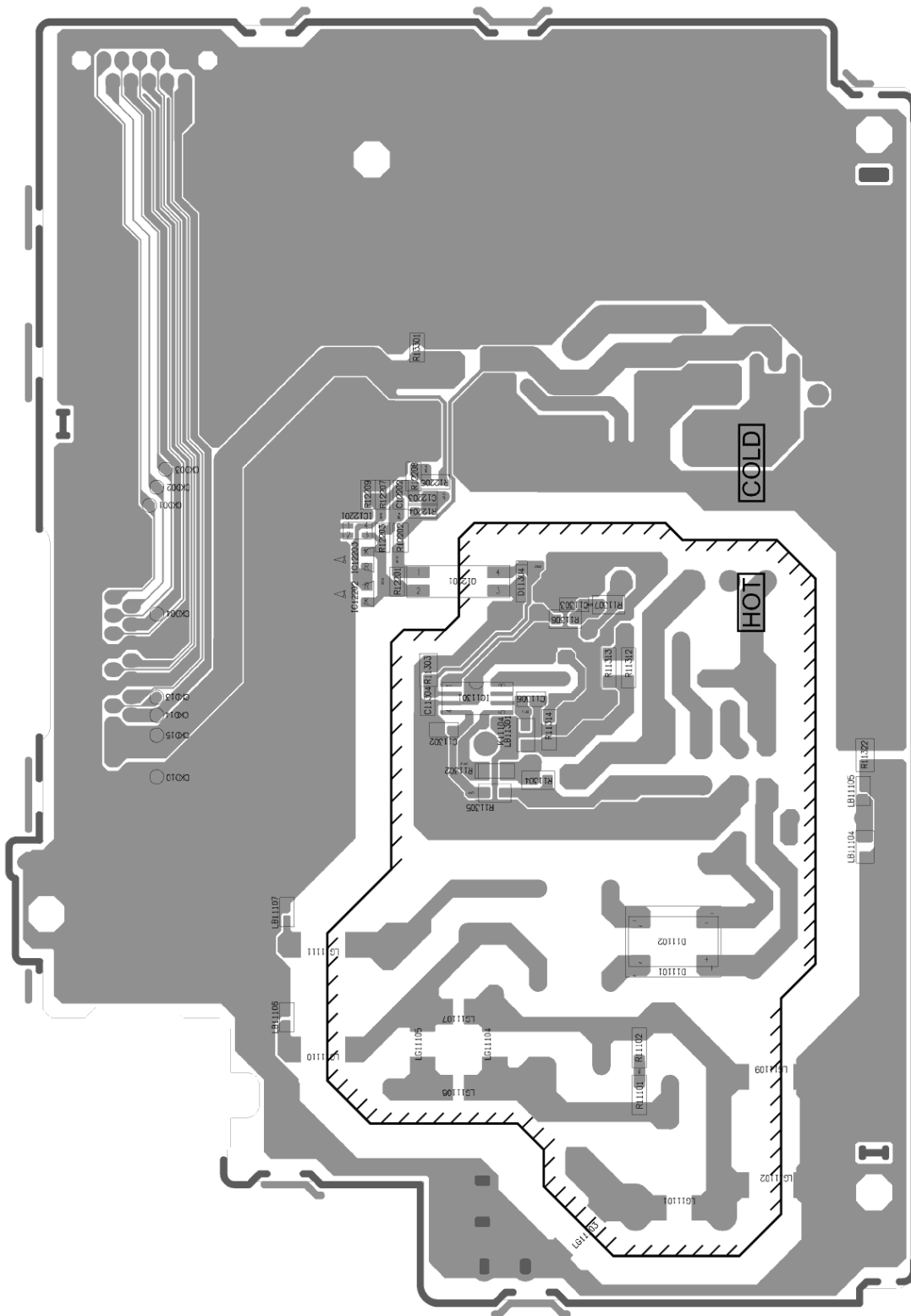

Model No. : DMR-BWT955GL D-AUDIO P.C.B.(COMPONENT SIDE)

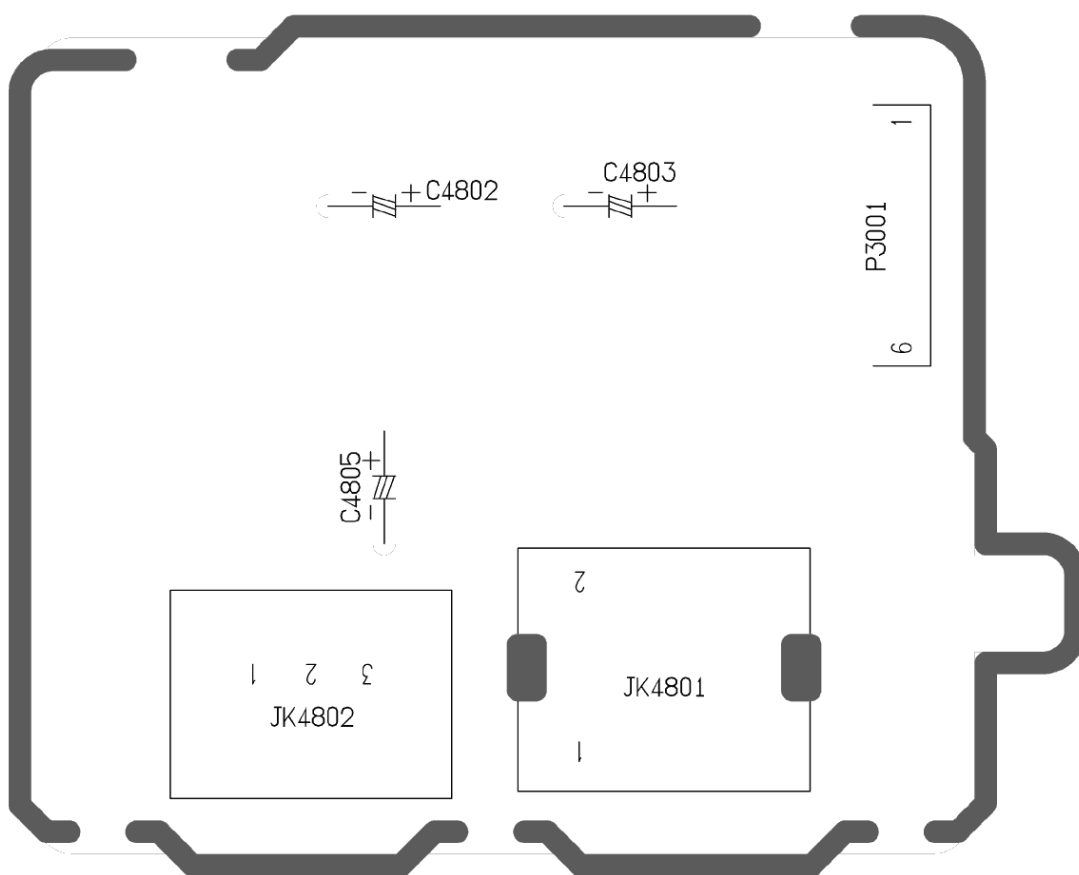

Model No. : DMR-BWT955GL D-AUDIO P.C.B.(FOIL SIDE)

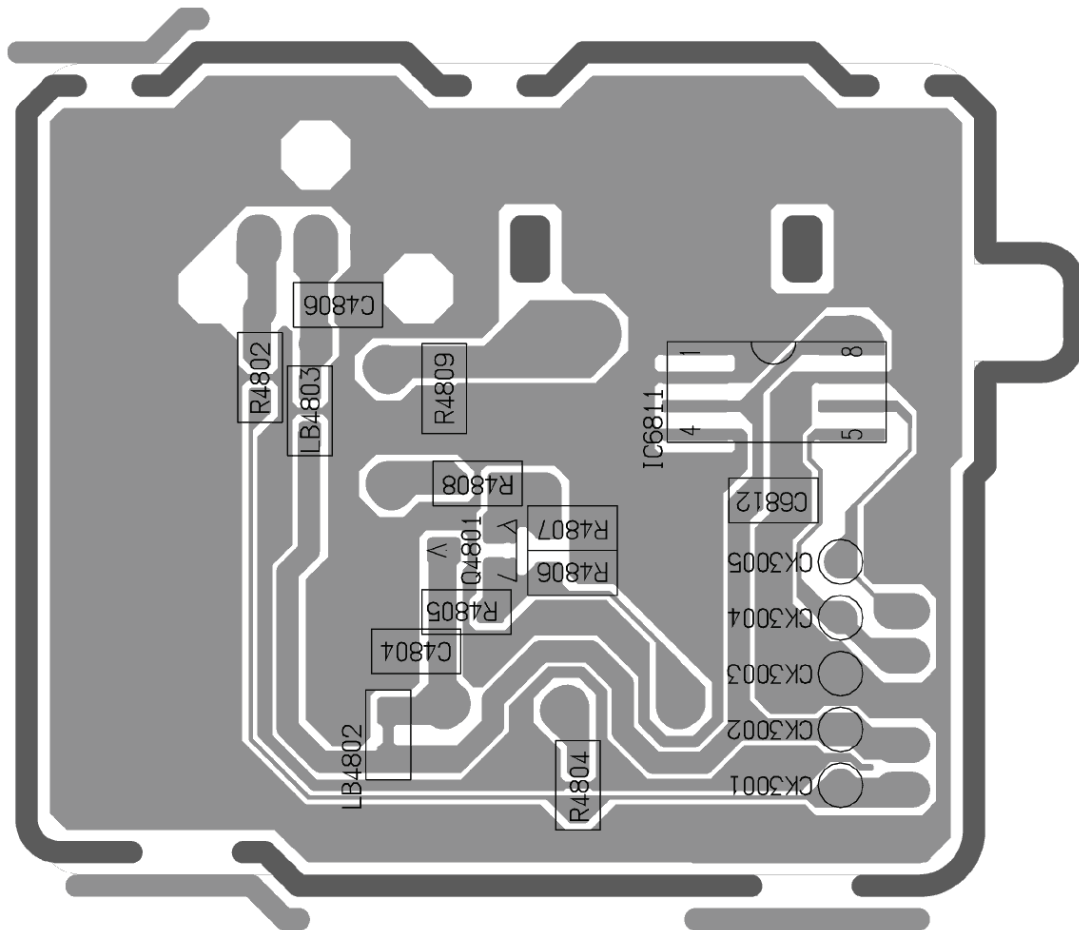

Model No. : DMR-BWT955GL DIGITAL P.C.B.(COMPONENT SIDE)

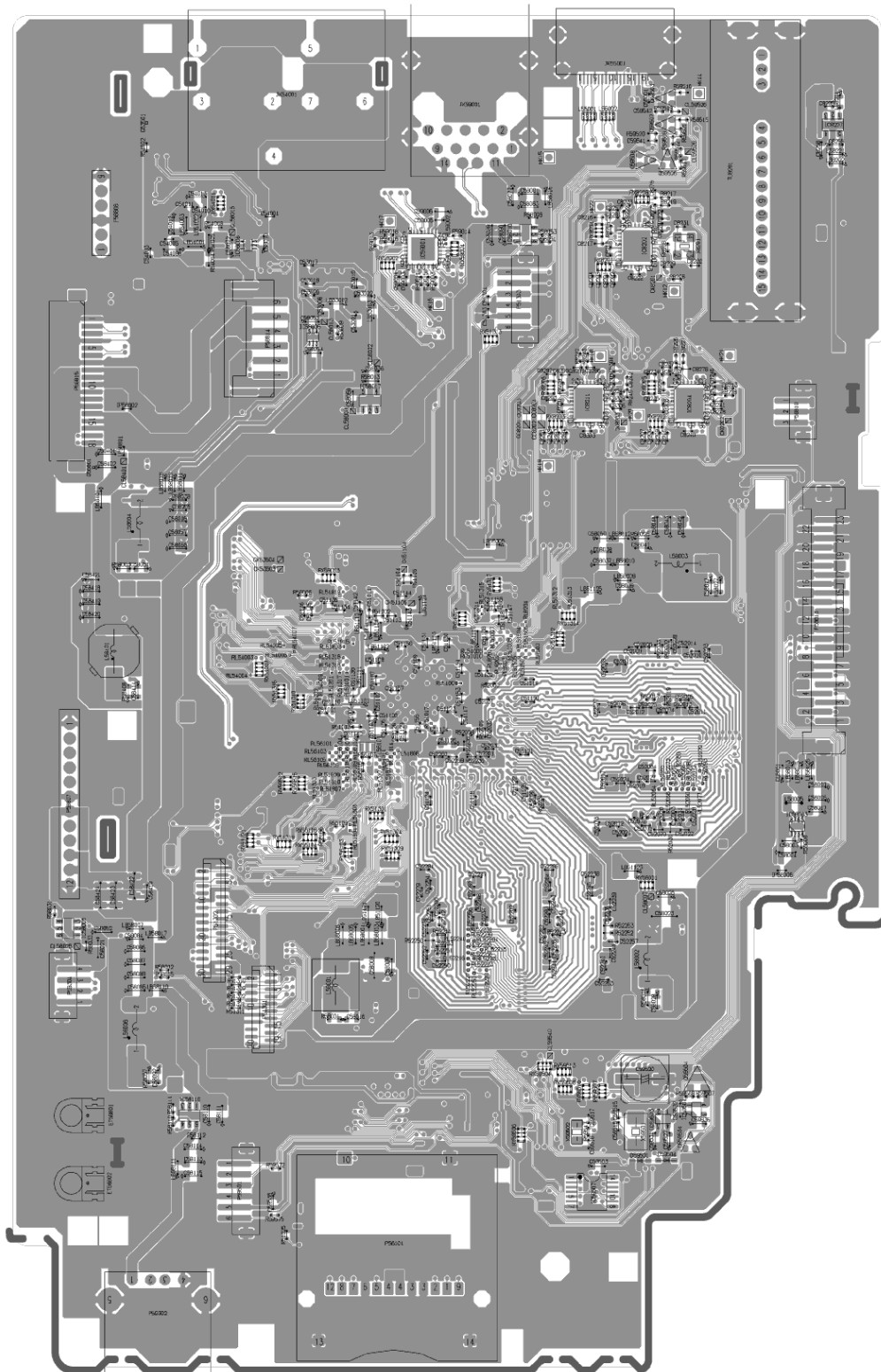

Model No. : DMR-BWT955GL DIGITAL P.C.B.(FOIL SIDE)

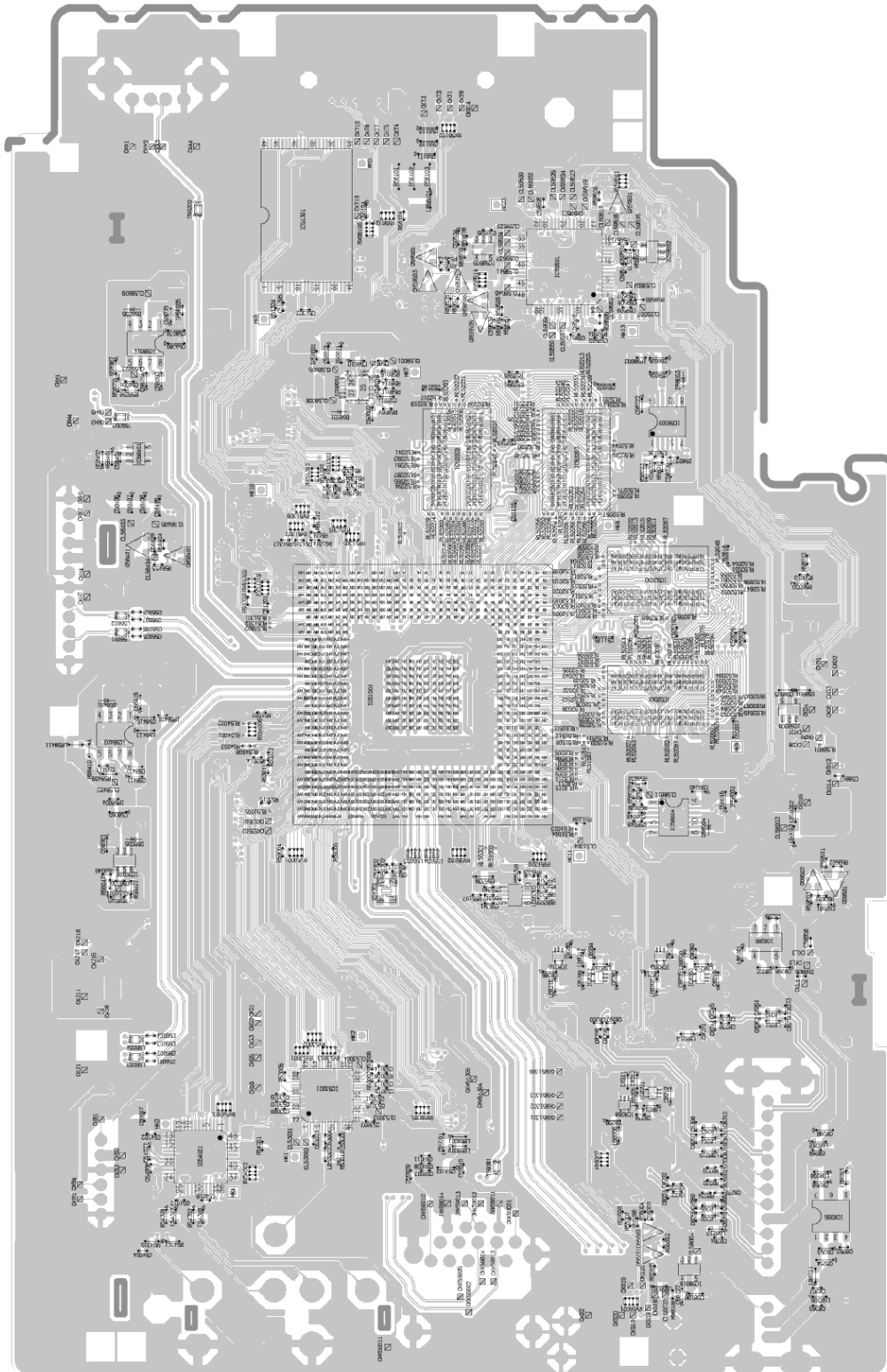

Model No. : DMR-BWT955GL HDD BRIDGE P.C.B.(COMPONENT SIDE)

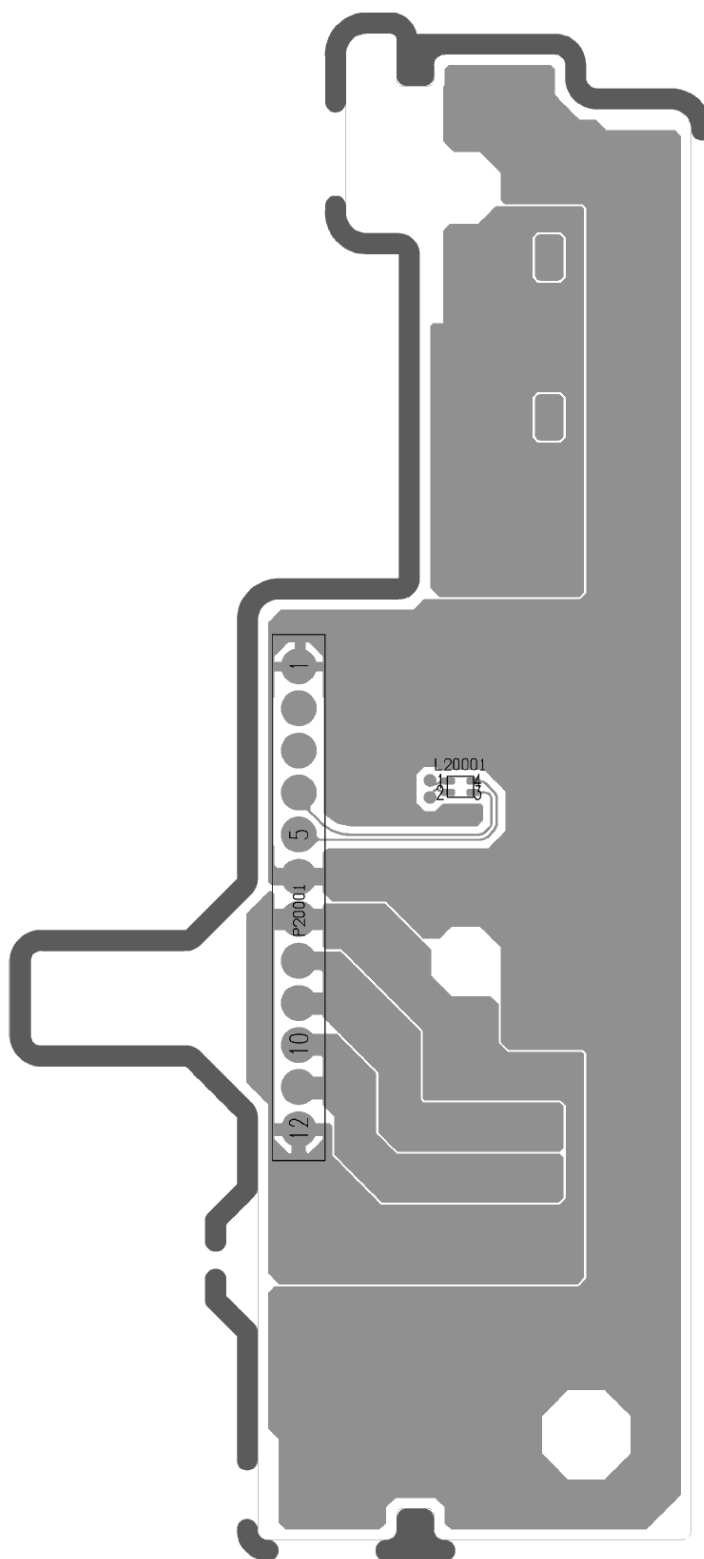

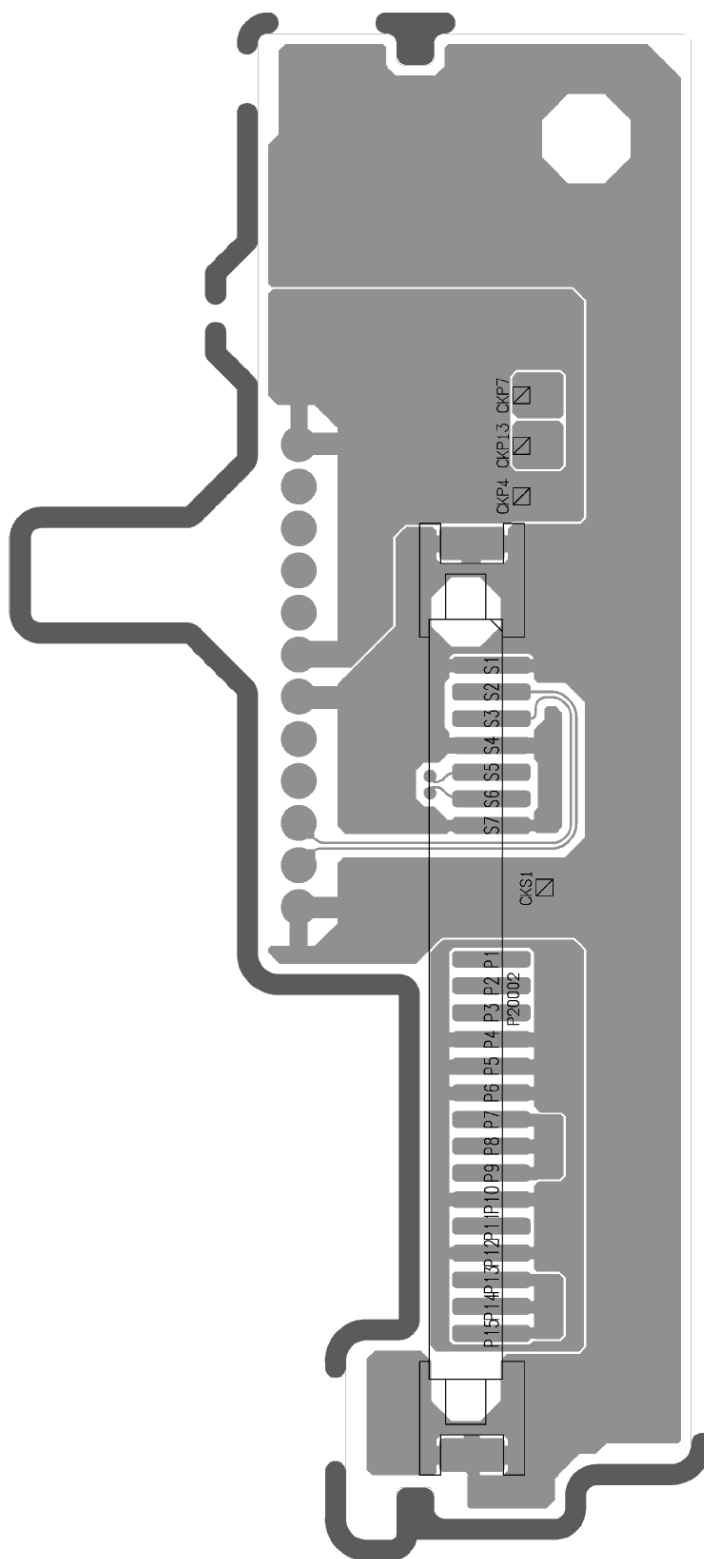

Model No. : DMR-BWT955GL HDD BRIDGE P.C.B.(FOIL SIDE)



Model No. : DMR-BWT955GL Parts List

Change	Safety	Ref. No.	Part No.	Part Name & Description	Q'ty	Remarks
		■	SEP0199AA	MAIN P.C.B.		(RTL) E.S.D.
	⚠	C11101	F0CAF683A150	250V 0.068U	1	
	⚠	C11102	F0CAF683A150	250V 0.068U	1	
	⚠	C11103	F1B2G4710004	400V 470P	1	
	⚠	C11104	F1B2G4710004	400V 470P	1	
		C11105	F2B2G6800020	400V 68U	1	
	⚠	C11106	F1B2G2220003	400V 0.0022U	1	
		C11301	F1B3D561A132	2000V 560P	1	
		C11302	F1H1H221B052	50V 220P	1	
		C11303	F1H1H221B052	50V 220P	1	
		C11304	F1H1H102B047	50V 0.001U	1	
		C11305	F2A1E1010103	25V 100U	1	
		C11306	F1H1H104A783	50V 0.1U	1	
		C11307	F1B3A2220012	1000V 0.0022U	1	
		C12202	F1H1C104A178	16V 0.1U	1	
		C12203	F1H1C104A178	16V 0.1U	1	
		C13201	F2A1C1020095	16V 1NF	1	
		C13202	F2A1C1020095	16V 1NF	1	
		C13203	F2A1C471A938	16V 470U	1	
		D11101	B0EDKT000009	DIODE	1	E.S.D.
		D11301	B0EAKV000090	DIODE	1	E.S.D.
		D11302	B0AADM000005	DIODE	1	E.S.D.
		D11304	DZ2W22000L	DIODE	1	E.S.D.
		D11308	B0EAKV000090	DIODE	1	E.S.D.
		D11309	B0EAKV000090	DIODE	1	E.S.D.
		D13201	B0JBSG000053	DIODE	1	E.S.D.
	⚠	F11101	K5G202YA0149	FUSE	1	
		IC11301	C0DBBY00061	IC	1	E.S.D.
		IC12201	C0DBZMC00006	IC	1	E.S.D.
		K11104	D0GDR00J0004	1/8W 0	1	
	⚠	L11101	G0B273E00006	COIL	1	
	⚠	L11102	G0B273E00006	COIL	1	
		L13201	G0A100H00025	COIL	1	
		LB11103	J0JKB0000003	COIL	1	
		LB11105	D0GBR00J0004	1/16W 0	1	
		LB11106	D0GBR00J0004	1/16W 0	1	
		LB11107	D0GBR00J0004	1/16W 0	1	
	⚠	P11101	K2AA2B000017	AC JACK	1	
		P7406	K1KY23AA1021	CONNECTOR (23P)	1	
		P7407	K1KB10B00045	CONNECTOR (10P)	1	
		Q11301	B1CERU000019	TRANSISTOR	1	E.S.D.
	⚠	Q12201	B3PBA0000579	TRANSISTOR	1	E.S.D.
	⚠	R11101	D0GF335JA048	1/2W 3300K	1	
	⚠	R11102	D0GF335JA048	1/2W 3300K	1	
		R11301	ERX2SJR27E	2W 0.27	1	
		R11302	ERJ14YJ100U	1/4W 10	1	
		R11303	D0GD473JA052	1/8W 47K	1	
		R11304	D0GD333JA052	1/8W 33K	1	
		R11305	D0GD101JA052	1/8W 100	1	
		R11306	D0GD103JA052	1/8W 10K	1	
		R11307	D0GD682JA052	1/8W 6.8K	1	
		R11312	D0GF8R2JA048	1/2W 8.2	1	
		R11313	D0GF8R2JA048	1/2W 8.2	1	
		R11316	ERG2SJ473E	2W 47K	1	
		R11317	ERG2SJ473E	2W 47K	1	
		R12201	D0GB102JA065	1/16W 1K	1	
		R12202	D0GB222JA065	1/16W 2.2K	1	
		R12203	D0GB103JA065	1/16W 10K	1	
		R12204	D0GB222JA065	1/16W 2.2K	1	
		R12206	D1BB3300A073	1/16W 33	1	
		R12207	D1BB4701A073	1/16W 47	1	
		R12208	D1BB1802A073	1/16W 18	1	

Model No. : DMR-BWT955GL Parts List

Change	Safety	Ref. No.	Part No.	Part Name & Description	Q'ty	Remarks
		T11301	G4DYA0000205	TRANSFORMER	1	
		VA11101	ERZE08A471CS	VARISTOR	1	
		ZA15301	K9ZZ00002324	EARTH PLATE	1	
		ZA15302	K9ZZ00002324	EARTH PLATE	1	
		ZA15303	K9ZZ00002324	EARTH PLATE	1	
		ZA15304	K9ZZ00002324	EARTH PLATE	1	
		■	SUKB0200AB	D-AUDIO P P.C.B.		(RTL) E.S.D.
		C4802	F2A0J470A599	6.3V 47U	1	
		C4803	F2A1E470A205	25V 47U	1	
		C4804	F1H1C104A041	16V 0.1U	1	
		C4805	F2A1E470A205	25V 47U	1	
		C4806	F1H1C105A167	16V 1U	1	
		C6812	F1H1C104A178	16V 0.1U	1	
		IC6811	SUCFT955GLE	IC	1	E.S.D.
		JK4801	K2HA102B0094	JACK	1	
		JK4802	B3ZAZ0000023	JACK,OPTICAL	1	
		LB4803	J0JYC0000070	COIL	1	
		P3001	K1KB06B00024	CONNECTOR(6P)	1	
		Q4801	B1ABDF000026	TRANSISTOR	1	E.S.D.
		R4802	D0GB101JA065	1/16W 100	1	
		R4804	D0GB102JA065	1/16W 1K	1	
		R4805	D0GB102JA065	1/16W 1K	1	
		R4806	D0GB152JA065	1/16W 1.5K	1	
		R4807	D0GB221JA065	1/16W 220	1	
		R4808	D0GB750JA065	1/16W 75	1	
		R4809	D0GB103JA065	1/16W 10K	1	
		■	SUKB0226AB	DIGITAL P.C.B.		E.S.D.
		C51001	F1G0J1050007	6.3V 1U	1	
		C51102	F1J0J106A020	6.3V 10U	1	
		C51103	F1J0J106A020	6.3V 10U	1	
		C51104	F1G1A1040006	10V 0.1U	1	
		C51105	F1G1A1040006	10V 0.1U	1	
		C51106	F1G1A1040006	10V 0.1U	1	
		C51107	F1G1A1040006	10V 0.1U	1	
		C51108	F1G1A1040006	10V 0.1U	1	
		C51109	F1G1A1040006	10V 0.1U	1	
		C51110	F1G1A1040006	10V 0.1U	1	
		C51111	F1G1A1040006	10V 0.1U	1	
		C51113	F1G1A1040006	10V 0.1U	1	
		C51115	F1J0J106A020	6.3V 10U	1	
		C51116	F1J0J106A020	6.3V 10U	1	
		C51117	F1G1A1040006	10V 0.1U	1	
		C51118	F1G1A1040006	10V 0.1U	1	
		C51119	F1G1A1040006	10V 0.1U	1	
		C51120	F1G1A1040006	10V 0.1U	1	
		C51121	F1G1A1040006	10V 0.1U	1	
		C51122	F1G1A1040006	10V 0.1U	1	
		C51123	F1G1A1040006	10V 0.1U	1	
		C51124	F1G1A1040006	10V 0.1U	1	
		C51125	F1G1A1040006	10V 0.1U	1	
		C51128	F1G1A1040006	10V 0.1U	1	
		C51129	F1G1A1040006	10V 0.1U	1	
		C51130	F1G1A1040006	10V 0.1U	1	
		C51131	F1G0J1050007	6.3V 1U	1	
		C51132	F1G1A1040006	10V 0.1U	1	
		C51134	F1G1A1040006	10V 0.1U	1	
		C51136	F1G1A1040006	10V 0.1U	1	
		C51138	F1G0J1050007	6.3V 1U	1	
		C51139	F1G0J1050007	6.3V 1U	1	
		C51140	F1H1A225A051	10V 2.2U	1	
		C51141	F1H1A225A051	10V 2.2U	1	
		C51142	F1G1A1040006	10V 0.1U	1	

Model No. : DMR-BWT955GL Parts List

Change	Safety	Ref. No.	Part No.	Part Name & Description	Q'ty	Remarks
		C51143	F1J0J106A020	6.3V 10U	1	
		C51144	F1G1A1040006	10V 0.1U	1	
		C51145	F1G0J1050007	6.3V 1U	1	
		C51146	F1G1A1040006	10V 0.1U	1	
		C51147	F1G0J1050007	6.3V 1U	1	
		C51148	F1G0J1050007	6.3V 1U	1	
		C51149	F1G0J1050007	6.3V 1U	1	
		C51158	F1G0J1050007	6.3V 1U	1	
		C51201	F1G1H5R0A831	50V 5P	1	
		C51202	F1G1H5R0A831	50V 5P	1	
		C51301	F1G1C1030008	16V 0.01U	1	
		C51302	F1G0J1050007	6.3V 1U	1	
		C51305	F1G1H470A834	50V 47P	1	
		C52001	F1G1A1040006	10V 0.1U	1	
		C52003	F1G1A1040006	10V 0.1U	1	
		C52004	F1G1A1040006	10V 0.1U	1	
		C52005	F1G1A1040006	10V 0.1U	1	
		C52006	F1G1A1040006	10V 0.1U	1	
		C52007	F1J0J106A020	6.3V 10U	1	
		C52008	F1G1A1040006	10V 0.1U	1	
		C52009	F1G1A1040006	10V 0.1U	1	
		C52010	F1G1A1040006	10V 0.1U	1	
		C52011	F1G1A1040006	10V 0.1U	1	
		C52016	F1J0J106A020	6.3V 10U	1	
		C52017	F1G1A1040006	10V 0.1U	1	
		C52018	F1G1A1040006	10V 0.1U	1	
		C52019	F1G1A1040006	10V 0.1U	1	
		C52020	F1G1A1040006	10V 0.1U	1	
		C52029	F1G0J1050007	6.3V 1U	1	
		C52030	F1G1A1040006	10V 0.1U	1	
		C52031	F1G1A1040006	10V 0.1U	1	
		C52032	F1G1A1040006	10V 0.1U	1	
		C52070	F1G1A1040006	10V 0.1U	1	
		C52071	F1G1A1040006	10V 0.1U	1	
		C52072	F1G1A1040006	10V 0.1U	1	
		C52073	F1G1A1040006	10V 0.1U	1	
		C52074	F1G1A1040006	10V 0.1U	1	
		C52075	F1G1A1040006	10V 0.1U	1	
		C52076	F1G1A1040006	10V 0.1U	1	
		C52077	F1G1A1040006	10V 0.1U	1	
		C52202	F1G1A1040006	10V 0.1U	1	
		C52233	F1G1A1040006	10V 0.1U	1	
		C52234	F1G1A1040006	10V 0.1U	1	
		C52235	F1G1A1040006	10V 0.1U	1	
		C52236	F1G1A1040006	10V 0.1U	1	
		C52237	F1J0J106A020	6.3V 10U	1	
		C52238	F1G1A1040006	10V 0.1U	1	
		C52239	F1G1A1040006	10V 0.1U	1	
		C52240	F1G1A1040006	10V 0.1U	1	
		C52241	F1G1A1040006	10V 0.1U	1	
		C52243	F1G1A1040006	10V 0.1U	1	
		C52246	F1J0J106A020	6.3V 10U	1	
		C52247	F1G1A1040006	10V 0.1U	1	
		C52248	F1G1A1040006	10V 0.1U	1	
		C52249	F1G1A1040006	10V 0.1U	1	
		C52250	F1G1A1040006	10V 0.1U	1	
		C52251	F1G1A1040006	10V 0.1U	1	
		C52254	F1G1A1040006	10V 0.1U	1	
		C52259	F1G1A1040006	10V 0.1U	1	
		C52260	F1G1A1040006	10V 0.1U	1	
		C52261	F1G1A1040006	10V 0.1U	1	
		C52278	F1G1A1040006	10V 0.1U	1	

Model No. : DMR-BWT955GL Parts List

Change	Safety	Ref. No.	Part No.	Part Name & Description	Q'ty	Remarks
		C52281	F1G1A1040006	10V 0.1U	1	
		C52284	F1G1A1040006	10V 0.1U	1	
		C53001	F1J0J106A020	6.3V 10U	1	
		C53002	F1J0J106A020	6.3V 10U	1	
		C53003	F1G1A1040006	10V 0.1U	1	
		C53004	F1G1A1040006	10V 0.1U	1	
		C53006	F1G1C1030008	16V 0.01U	1	
		C53008	F1G1A1040006	10V 0.1U	1	
		C53009	F1G0J1050007	6.3V 1U	1	
		C53010	F1G1A1040006	10V 0.1U	1	
		C53011	F1G1A1040006	10V 0.1U	1	
		C53012	F1G1A1040006	10V 0.1U	1	
		C53013	F1G1A1040006	10V 0.1U	1	
		C53014	F1G1A1040006	10V 0.1U	1	
		C53015	F1G1A1040006	10V 0.1U	1	
		C53016	F1G1A1040006	10V 0.1U	1	
		C53017	F1G1A1040006	10V 0.1U	1	
		C53018	F1G1A1040006	10V 0.1U	1	
		C53019	F1G1A1040006	10V 0.1U	1	
		C53020	F1G1A1040006	10V 0.1U	1	
		C54005	F1G1A1040006	10V 0.1U	1	
		C54006	F1J0J106A020	6.3V 10U	1	
		C54007	F1H1C105A167	16V 1U	1	
		C54008	F1G0J1050007	6.3V 1U	1	
		C54010	F1G1A1040006	10V 0.1U	1	
		C54012	F1J0J106A020	6.3V 10U	1	
		C54016	F1G0J1050007	6.3V 1U	1	
		C54017	F1G0J1050007	6.3V 1U	1	
		C54317	F1H1H102A831	50V 0.001U	1	
		C54318	F1H1H102A831	50V 0.001U	1	
		C55001	F1G1A1040006	10V 0.1U	1	
		C56001	F1G1C1030008	16V 0.01U	1	
		C56002	F1G1C1030008	16V 0.01U	1	
		C56003	F1G1C1030008	16V 0.01U	1	
		C56004	F1G1C1030008	16V 0.01U	1	
		C56005	F1G1C1030008	16V 0.01U	1	
		C56006	F1G1C1030008	16V 0.01U	1	
		C56007	F1G1C1030008	16V 0.01U	1	
		C56008	F1G1C1030008	16V 0.01U	1	
		C56102	F1J0J2260004	6.3V 22U	1	
		C56103	F1J0J106A014	6.3V 10U	1	
		C56104	F1H1H103B047	50V 0.01U	1	
		C58002	F1H1E104A161	25V 0.1U	1	
		C58003	F1H1E104A161	25V 0.1U	1	
		C58004	F1J1C1060001	16V 10U	1	
		C58005	F1J1C1060001	16V 10U	1	
		C58006	F1J0J106A014	6.3V 10U	1	
		C58007	F1J1C1060001	16V 10U	1	
		C58008	F1LOG107A002	4V 100U	1	
		C58009	F1H1C104A178	16V 0.1U	1	
		C58010	F1H1E104A161	25V 0.1U	1	
		C58011	F1J1C1060001	16V 10U	1	
		C58012	F1J1C1060001	16V 10U	1	
		C58013	F1J1C1060001	16V 10U	1	
		C58014	F1H1C105A167	16V 1U	1	
		C58015	F1G1C822A081	16V 8200P	1	
		C58016	F1H1E104A161	25V 0.1U	1	
		C58017	F1H1C104A178	16V 0.1U	1	
		C58018	F1G1A473A069	10V 0.047U	1	
		C58021	F1J0J106A014	6.3V 10U	1	
		C58022	F1H1E104A161	25V 0.1U	1	
		C58023	F1LOG107A002	6.3V 22U	1	

Model No. : DMR-BWT955GL Parts List

Change	Safety	Ref. No.	Part No.	Part Name & Description	Q'ty	Remarks
		C58024	F1J1C1060001	16V 10U	1	
		C58025	F1J1C1060001	16V 10U	1	
		C58026	F1H1C104A178	16V 0.1U	1	
		C58027	F1G1C153A146	16V 0.015U	1	
		C58028	F1H1E104A161	25V 0.1U	1	
		C58029	F1H1C105A167	16V 1U	1	
		C58035	F1G1H470A834	50V 47P	1	
		C58036	F1H1C105A167	16V 1U	1	
		C58037	F1J0J2260004	6.3V 22U	1	
		C58038	F1J0J2260004	6.3V 22U	1	
		C58039	F1H1C104A178	16V 0.1U	1	
		C58040	F1H1E104A161	25V 0.1U	1	
		C58041	F1H1C104A178	16V 0.1U	1	
		C58042	F1J0J106A014	6.3V 10U	1	
		C58043	F1J0J106A014	6.3V 10U	1	
		C58044	F1J0J106A014	6.3V 10U	1	
		C58045	F1J1C1060001	16V 10U	1	
		C58046	F1G1E222A144	25V 0.0022U	1	
		C58047	F1H1E104A161	25V 0.1U	1	
		C58048	F1H1C105A167	16V 1U	1	
		C58049	F1G1H470A834	50V 47P	1	
		C58050	F1H1C104A178	16V 0.1U	1	
		C58051	F1H1E104A161	25V 0.1U	1	
		C58052	F1J0J106A014	6.3V 10U	1	
		C58053	F1H1C105A167	16V 1U	1	
		C58054	F1H1C105A167	16V 1U	1	
		C58055	F1H1C104A178	16V 0.1U	1	
		C58056	F1J0J106A014	6.3V 10U	1	
		C58057	F1J0J106A014	6.3V 10U	1	
		C58059	F1H1C105A167	16V 1U	1	
		C58061	F1H1C104A178	16V 0.1U	1	
		C58062	F1J1C1060001	16V 10U	1	
		C58063	F1H1E104A161	25V 0.1U	1	
		C58070	F1H1C105A167	16V 1U	1	
		C58072	F1H1C105A167	16V 1U	1	
		C58079	F1J1C1060001	16V 10U	1	
		C58080	F1J1C1060001	16V 10U	1	
		C58083	F1J0J106A014	6.3V 10U	1	
		C58084	F1H1C104A178	16V 0.1U	1	
		C58085	F1J0J106A014	6.3V 10U	1	
		C58086	F1J0J106A014	6.3V 10U	1	
		C58087	F1J0J106A014	6.3V 10U	1	
		C58088	F1J0J106A014	6.3V 10U	1	
		C58089	F1J0J106A014	6.3V 10U	1	
		C58090	F1J0J106A014	6.3V 10U	1	
		C58092	F1H1E104A161	25V 0.1U	1	
		C58093	F1H1C104A178	16V 0.1U	1	
		C58094	F1H1C105A167	16V 1U	1	
		C58110	F1J0J106A014	6.3V 10U	1	
		C58111	F1J0J106A014	6.3V 10U	1	
		C58113	F1J0J106A014	6.3V 10U	1	
		C58127	F1H1C105A167	6.3V 10U	1	
		C58128	F1H1C105A167	6.3V 10U	1	
		C58405	F1J1C1060001	16V 10U	1	
		C58406	F1J1C1060001	16V 10U	1	
		C58407	F1J1C1060001	16V 10U	1	
		C58408	F1J1C1060001	16V 10U	1	
		C58409	F1H1C105A167	16V 1U	1	
		C58411	F1H1C105A167	16V 1U	1	
		C58412	F1H1C104A178	16V 0.1U	1	
		C58413	F1J1C1060001	16V 10U	1	
		C58414	F1H1E104A161	25V 0.1U	1	

Model No. : DMR-BWT955GL Parts List

Change	Safety	Ref. No.	Part No.	Part Name & Description	Q'ty	Remarks
		C58415	F1J1C1060001	16V 10U	1	
		C58418	F1J0J106A014	6.3V 10U	1	
		C58419	F1J0J106A014	6.3V 10U	1	
		C58420	F1J0J106A014	6.3V 10U	1	
		C58421	F1H1C104A178	16V 0.1U	1	
		C58422	F1K0J2260004	6.3V 22U	1	
		C58423	F1K0J2260004	6.3V 22U	1	
		C58424	F1K0J2260004	6.3V 22U	1	
		C58801	F1H1C105A167	16V 1U	1	
		C58805	F1H1C105A167	16V 1U	1	
		C58806	F1G1C1030008	16V 0.01U	1	
		C58807	F1G1E102A086	25V 1000P	1	
		C58808	F1G1H101A834	50V 100P	1	
		C58817	F1G1E102A086	25V 1000P	1	
		C59003	F1G1A1040006	10V 0.1U	1	
		C59005	F1G1A1040006	10V 0.1U	1	
		C59006	F1H1A225A102	10V 2.2U	1	
		C59008	F1G1A1040006	10V 0.1U	1	
		C59009	F1G1A1040006	10V 0.1U	1	
		C59010	F1G1A1040006	10V 0.1U	1	
		C59011	F1G0J1050007	6.3V 1U	1	
		C59501	F1H1C104A178	16V 0.1U	1	
		C59502	F1G1A1040006	10V 0.1U	1	
		C59503	F1H1C104A178	16V 0.1U	1	
		C59507	F1G1C1030008	16V 0.01U	1	
		C59508	F1G1C1030008	16V 0.01U	1	
		C59509	F1G1C1030008	16V 0.01U	1	
		C59510	F1G1C1030008	16V 0.01U	1	
		C59511	F1G1C1030008	16V 0.01U	1	
		C59514	F1G1A1040006	10V 0.1U	1	
		C59515	F1G1H8R0A833	50V 8P	1	
		C59516	F1G1H8R0A833	50V 8P	1	
		C59517	F1G1H7R0A833	50V 12P	1	
		C59518	F1G1H8R0A833	50V 12P	1	
		C59524	F1G1A1040006	10V 0.1U	1	
		C59525	F1G1H101A834	50V 100P	1	
		C59526	F1G1C1030008	16V 0.01U	1	
		C59527	F1H1C105A167	16V 1U	1	
		C59531	F1H1C105A167	16V 1U	1	
		C59532	F1H1C105A167	16V 1U	1	
		C59534	F1H1C104A178	16V 0.1U	1	
		C59535	F1H1C105A167	16V 1U	1	
		C59541	F1G1H221A834	50V 220P	1	
		C8205	F1G1A1040006	16V 0.1U	1	
		C8208	F1H1C105A167	6.3V 1U	1	
		C8211	F1H1C105A167	6.3V 1U	1	
		C8212	F1H1C105A167	16V 1U	1	
		C8213	F1H1C105A167	16V 1U	1	
		C8214	F1H1C105A167	6.3V 1U	1	
		C8215	F1H1C105A167	6.3V 1U	1	
		C8216	F1G1H150A834	50V 15P	1	
		C8217	F1G1H150A834	50V 15P	1	
		C8218	F1G1A1040006	10V 0.1U	1	
		C8219	F1H1C105A167	16V 1U	1	
		C8220	F1G1A1040006	50V 8P	1	
		C8221	F1G1A1040006	50V 8P	1	
		C8222	F1G1A1040006	10V 0.1U	1	
		C8225	F1H1C105A167	16V 1U	1	
		C8226	F1G1A473A069	50V 8P	1	
		C8227	F1G1A1040006	10V 0.1U	1	
		C8228	F1G1A1040006	10V 0.1U	1	
		C8229	F1G1A1040006	10V 0.1U	1	

Model No. : DMR-BWT955GL Parts List

Change	Safety	Ref. No.	Part No.	Part Name & Description	Q'ty	Remarks
		C8230	F1H1A105A036	50V 8P	1	
		C8231	F1G1H100A834	50V 10P	1	
		C8232	F1G1H120A834	50V 10P	1	
		C8233	F1G1H560A834	50V 56P	1	
		C8234	F1G1H150A834	50V 15P	1	
		C8235	F1G1H150A834	50V 15P	1	
		C8236	F1G1A1040006	10V 0.1U	1	
		C8238	F1G1A1040006	10V 0.1U	1	
		C8239	F1G1A1040006	10V 0.1U	1	
		C8240	F1G1A1040006	10V 0.1U	1	
		C8242	F1G1E102A086	50V 8P	1	
		C8243	F1G1E102A086	50V 8P	1	
		C8246	F1G1A1040006	10V 0.1U	1	
		C8247	F1G1A1040006	10V 0.1U	1	
		C8248	F1G1A1040006	10V 0.1U	1	
		C8250	F1H1A105A036	50V 8P	1	
		C8252	F1G1H471A541	16V 1U	1	
		C8253	F1H0J4750004	16V 1U	1	
		C8255	F1H1C105A167	10V 0.1U	1	
		C8256	F1H0J4750004	6.3V 10U	1	
		C8258	F1H1C105A167	16V 1U	1	
		C8263	F1G1E102A086	25V 1000P	1	
		C8264	F1G1E102A086	25V 1000P	1	
		C8265	F1G1H8R0A833	50V 8P	1	
		C8266	F1G1H8R0A833	50V 8P	1	
		C8267	F1G0J1050007	6.3V 1U	1	
		C8268	F1G0J1050007	6.3V 1U	1	
		C8271	F1G1E102A086	25V 1000P	1	
		C8273	F1G1H8R0A833	50V 8P	1	
		C8274	F1G1H8R0A833	50V 8P	1	
		C8275	F1G1H8R0A833	50V 8P	1	
		C8276	F1G1H8R0A833	50V 8P	1	
		C8277	F1G1H8R0A833	50V 8P	1	
		C8278	F1G1H8R0A833	50V 8P	1	
		C8281	F1G1A1040006	10V 0.1U	1	
		C8282	F1G1A1040006	10V 0.1U	1	
		C8285	F1H1C105A167	16V 1U	1	
		C8286	F1H1C105A167	16V 1U	1	
		C8287	F1H1C105A167	16V 1U	1	
		C8289	F1H1C105A167	16V 1U	1	
		C8290	F1G1A1040006	10V 0.1U	1	
		C8291	F1G1A1040006	10V 0.1U	1	
		C8292	F1G1H150A834	50V 15P	1	
		C8293	F1G1H150A834	50V 15P	1	
		C8295	F1G1H8R0A833	50V 8P	1	
		C8296	F1G1H8R0A833	50V 8P	1	
		C8298	F1G1A1040006	10V 0.1U	1	
		C8299	F1G1A1040006	10V 0.1U	1	
		C8303	F1G1A1040006	10V 0.1U	1	
		C8304	F1G1A1040006	10V 0.1U	1	
		C8305	F1G1A1040006	10V 0.1U	1	
		C8306	F1G1A1040006	10V 0.1U	1	
		C8310	F1G1E102A086	25V 1000P	1	
		C8311	F1G1H8R0A833	50V 8P	1	
		C8312	F1G1H8R0A833	50V 8P	1	
		D58001	B0JCMD000077	DIODE	1	E.S.D.
		D58003	B0JCMD000077	DIODE	1	E.S.D.
		D58004	B0JCMD000077	DIODE	1	E.S.D.
		D58006	B0JCMD000077	DIODE	1	E.S.D.
		D58401	B0JCMD000077	DIODE	1	E.S.D.
		ET58801	K4AD01D00006	EARTH PLATE	1	
		ET58802	K4AD01D00006	EARTH PLATE	1	

Model No. : DMR-BWT955GL Parts List

Change	Safety	Ref. No.	Part No.	Part Name & Description	Q'ty	Remarks
		IC51001	SUKB0226AB	IC	1	E.S.D.
		IC51301	SUKB0226AB	IC	1	E.S.D.
		IC52000	C3ABUY000051	IC	1	E.S.D.
		IC52001	C3ABUY000051	IC	1	E.S.D.
		IC52202	C3ABUY000051	IC	1	E.S.D.
		IC52203	C3ABUY000051	IC	1	E.S.D.
		IC53001	AN13351A-VTR	IC	1	E.S.D. SPC
		IC54001	C1AB00003695	IC	1	E.S.D.
		IC58001	VUEALLPT061	IC	1	E.S.D. .SPC
		IC58002	C0DBAYY01499	IC	1	E.S.D.
		IC58003	C0DBAYY01798	IC	1	E.S.D.
		IC58004	C0DBAYY01361	IC	1	E.S.D.
		IC58005	C0DBZYY00541	IC	1	E.S.D.
		IC58006	C0DBGYY04527	IC	1	E.S.D.
		IC58008	C0DBGYY04527	IC	1	E.S.D.
		IC58009	C0DBAYY02112	IC	1	E.S.D.
		IC58010	C0DBZYY00577	IC	1	E.S.D.
		IC58011	C0DBAYY01445	IC	1	E.S.D.
		IC58017	C0DBGYY03536	IC	1	E.S.D.
		IC58018	C0DBGYY03536	IC	1	E.S.D.
		IC58099	C0DBGYY03536	IC	1	E.S.D.
		IC58110	C0DBZYY00577	IC	1	E.S.D.
		IC58401	C0EBK0000206	IC	1	E.S.D.
		IC58402	C0DBAYY01445	IC	1	E.S.D.
		IC59001	VUEALLPT085	IC	1	E.S.D. SPC
		IC59501	MN101C77DMM	IC	1	E.S.D.
		IC59502	COEBY0001142	IC	1	E.S.D.
		IC59503	C0DBGYY03975	IC	1	E.S.D.
		IC59504	C0DBGYY03272	IC	1	E.S.D.
		IC59505	C0EBK0000206	IC	1	E.S.D.
		IC59507	C0JBAZ001652	IC	1	E.S.D.
		IC8201	C0DBGYY04527	IC	1	E.S.D.
		IC8202	SUBF000008	IC	1	E.S.D.
		IC8203	C0DBGYY04527	IC	1	E.S.D.
		IC8204	SUBF000008	IC	1	E.S.D.
		IC8205	C0DBGFF00004	IC	1	E.S.D.
		IC8206	C0DBGGD00087	IC	1	E.S.D.
		IC8207	C0DBGYY03536	IC	1	E.S.D.
		IC8208	C0DBGYY04532	IC	1	E.S.D.
		IC8209	C0DBGYY04532	IC	1	E.S.D.
		IC8210	C0DBGYY04532	IC	1	E.S.D.
		IC8211	SUBF000008	IC	1	E.S.D.
		IC8212	C0DBGYY04527	IC	1	E.S.D.
	⚠	IP58001	ERBRD2R00X	IC PROTECTOR	1	
	⚠	IP58002	ERBRD1R50X	IC PROTECTOR	1	
	⚠	IP58003	ERBRD1R50X	IC PROTECTOR	1	
	⚠	IP58004	ERBRD1R50X	IC PROTECTOR	1	
	⚠	IP58005	ERBRD2R00X	IC PROTECTOR	1	
	⚠	IP58006	ERBRD1R50X	IC PROTECTOR	1	
	⚠	IP58401	ERBRD2R00X	IC PROTECTOR	1	
	⚠	IP58801	ERBRD2R50X	IC PROTECTOR	1	
	⚠	IP58802	ERBRD2R50X	IC PROTECTOR	1	
	⚠	IP59501	ERBRD0R75X	IC PROTECTOR	1	
		JK54001	K2HA3YYA0007	JACK AV	1	
		JK55001	K1FY119E0079	JACK HDMI	1	
		JK59001	K2LD214B0003	JACK LAN	1	
		L55001	EXC28CH900U	FILTER	1	
		L55002	EXC28CH900U	FILTER	1	
		L56001	J0ZZB0000190	COIL	1	
		L56003	J0ZZB0000190	COIL	1	
		L56004	J0ZZB0000190	COIL	1	
		L58001	G1C1R5M00010	COIL	1	

Model No. : DMR-BWT955GL Parts List

Change	Safety	Ref. No.	Part No.	Part Name & Description	Q'ty	Remarks
		L58002	G1C2R2Z00006	COIL	1	
		L58003	G1C4R7Z00014	COIL	1	
		L58004	G1C4R7Z00014	COIL	1	
		L58005	G1C2R2MA0625	COIL	1	
		L58006	G1C3R3Z00005	COIL	1	
		L58401	G1C3R3ZA0350	COIL	1	
		L8201	G1CR22JA0020	COIL	1	
		L8202	G1CR22JA0020	COIL	1	
		L8203	G1CR22JA0020	COIL	1	
		L8204	G1CR22JA0020	COIL	1	
		L8205	G1CR22JA0020	COIL	1	
		L8206	G1CR22JA0020	COIL	1	
		LB51113	J0JHC0000046	COIL	1	
		LB51120	J0JHC0000018	COIL	1	
		LB51121	J0JHC0000018	COIL	1	
		LB51123	J0JHC0000046	COIL	1	
		LB51125	J0JHC0000046	COIL	1	
		LB53001	J0JYC0000024	COIL	1	
		LB53002	J0JYC0000070	COIL	1	
		LB53003	J0JYC0000070	COIL	1	
		LB58001	J0JGC0000020	COIL	1	
		LB58002	J0JHC0000046	COIL	1	
		LB58003	D0GDR00J0004	1/8W 0	1	
		LB58004	D0GDR00J0004	1/8W 0	1	
		LB58005	D0GDR00J0004	1/8W 0	1	
		LB58006	D0GDR00J0004	1/8W 0	1	
		LB58007	J0JGC0000020	COIL	1	
		LB58008	J0JHC0000046	COIL	1	
		LB58010	J0JHC0000046	COIL	1	
		LB58011	J0JHC0000046	COIL	1	
		LB58012	J0JHC0000046	COIL	1	
		LB58013	J0JGC0000020	COIL	1	
		LB58015	J0JGC0000020	COIL	1	
		LB58016	J0JGC0000020	COIL	1	
		LB58017	J0JGC0000020	COIL	1	
		LB58018	J0JGC0000020	COIL	1	
		LB58019	J0JGC0000020	COIL	1	
		LB58025	J0JGC0000020	COIL	1	
		LB58110	J0JGC0000020	COIL	1	
		LB58111	J0JGC0000020	COIL	1	
		LB58401	D0GDR00J0004	1/8W 0	1	
		LB59002	J0JGC0000020	COIL	1	
		LB8201	D0GBR00J0004	1/16W 0	1	
		LB8202	D0GBR00J0004	1/16W 0	1	
		LB8203	D0GBR00J0004	1/16W 0	1	
		LB8204	D0GBR00J0004	1/16W 0	1	
		LB8205	D0GBR00J0004	1/16W 0	1	
		LB8206	J0JCC0000103	COIL	1	
		LB8207	J0JCC0000103	COIL	1	
		LB8208	D0GBR00J0004	1/16W 0	1	
		LB8209	J0JCC0000103	COIL	1	
		LB8210	J0JCC0000103	COIL	1	
		LB8211	D0GBR00J0004	1/16W 0	1	
		LB8212	D0GBR00J0004	1/16W 0	1	
		LB8213	J0JCC0000103	COIL	1	
		LB8214	J0JGC0000020	COIL	1	
		LB8215	J0JGC0000020	COIL	1	
		LB8216	J0JCC0000103	COIL	1	
		LB8217	D0GBR00J0004	1/16W 0	1	
		LB8218	J0JGC0000020	COIL	1	
		LB8219	J0JCC0000103	COIL	1	
		LB8220	D0GBR00J0004	1/16W 0	1	

Model No. : DMR-BWT955GL Parts List

Change	Safety	Ref. No.	Part No.	Part Name & Description	Q'ty	Remarks
		LB8221	D0GBR00J0004	1/16W 0	1	
		P51303	K1KY06AA1485	CONNECTOR (6P)	1	
		P56101	K1NA09E00098	CONNECTOR (9P)	1	
		P58807	K1KA12Z00002	CONNECTOR (12P)	1	
		P58808	K1KA06A00474	CONNECTOR (6P)	1	
		P58810	K1KY03AA1485	CONNECTOR (3P)	1	
		P58813	K1KY23AA1442	CONNECTOR (23P)	1	
		P58815	K1MN18BA0147	CONNECTOR (18P)	1	
		P59302	K1FY104B0104	CONNECTOR (10P)	1	
		P59304	K1KY04AA1485	CONNECTOR (4P)	1	
		Q55001	B1ABDF000026	TRANSISTOR	1	E.S.D.
		Q55002	B1ABDF000026	TRANSISTOR	1	E.S.D.
		Q58401	B1CHRD000092	TRANSISTOR	1	E.S.D.
		Q59501	B1ADGG000004	TRANSISTOR	1	E.S.D.
		Q59502	B1ABDF000026	TRANSISTOR	1	E.S.D.
		Q59503	B1ABDF000026	TRANSISTOR	1	E.S.D.
		Q59506	B1ABDF000026	TRANSISTOR	1	E.S.D.
		Q59507	B1ABDF000026	TRANSISTOR	1	E.S.D.
		Q59508	B1ABDF000026	TRANSISTOR	1	E.S.D.
		QR58401	B1GBCFNN0041	TRANSISTOR	1	E.S.D.
		QR59501	B1GBCFNN0041	TRANSISTOR	1	E.S.D.
		QR59505	B1GD CFGG0028	TRANSISTOR	1	E.S.D.
		QR59506	B1GBCFNN0041	TRANSISTOR	1	E.S.D.
		R51001	D1BA1540A023	1/16W 154	1	
		R51002	D1BA6201A023	1/16W 6.2K	1	
		R51003	D1BA6201A023	1/16W 6.2K	1	
		R51104	ERJ2RHD471X	1/16W 470	1	
		R51202	D0GAR00J0005	1/16W 0	1	
		R51301	D0GA332JA023	1/16W 3.3K	1	
		R51302	D0GA332JA023	1/16W 3.3K	1	
		R51303	D0GA332JA023	1/16W 3.3K	1	
		R51304	D0GA332JA023	1/16W 3.3K	1	
		R51306	D0GA332JA023	1/16W 3.3K	1	
		R51309	D0GA332JA023	1/16W 3.3K	1	
		R51312	D0GA222JA023	1/16W 2.2K	1	
		R51314	D0GA222JA023	1/16W 2.2K	1	
		R51315	D0GA222JA023	1/16W 2.2K	1	
		R51323	D0GA472JA023	1/16W 4.7K	1	
		R51324	D0GA472JA023	1/16W 4.7K	1	
		R52000	ERJ2RHD241X	1/16W 240	1	
		R52017	D0GA221JA023	1/16W 220	1	
		R52018	D0GA221JA023	1/16W 220	1	
		R52019	ERJ2RHD241X	1/16W 240	1	
		R52020	ERJ2RHD241X	1/16W 240	1	
		R52021	D0GA103JA023	1/16W 10K	1	
		R52030	ERJ2RHD271X	1/16W 270	1	
		R52031	ERJ2RHD271X	1/16W 270	1	
		R52032	ERJ2RHD271X	1/16W 270	1	
		R52033	ERJ2RHD271X	1/16W 270	1	
		R52234	ERJ2RHD241X	1/16W 240	1	
		R52235	ERJ2RHD271X	1/16W 270	1	
		R52238	ERJ2RHD271X	1/16W 270	1	
		R52241	D0GA221JA023	1/16W 110	1	
		R52242	D0GA221JA023	1/16W 220	1	
		R52243	ERJ2RHD241X	1/16W 240	1	
		R52244	ERJ2RHD241X	1/16W 240	1	
		R52245	D0GA103JA023	1/16W 10K	1	
		R52250	ERJ2RHD271X	1/16W 270	1	
		R52251	ERJ2RHD271X	1/16W 270	1	
		R52252	ERJ2RHD271X	1/16W 270	1	
		R52253	ERJ2RHD271X	1/16W 270	1	
		R53005	D0GA220JA023	1/16W 22	1	

Model No. : DMR-BWT955GL Parts List

Change	Safety	Ref. No.	Part No.	Part Name & Description	Q'ty	Remarks
		R53006	D0GA472JA023	1/16W 4.7K	1	
		R53007	D0GA103JA023	1/16W 10K	1	
		R53008	D0GA133JA023	1/16W 13K	1	
		R53009	D0GA222JA023	1/16W 2.2K	1	
		R53011	D0GA680JA023	1/16W 68	1	
		R53012	D0GA470JA023	1/16W 47	1	
		R53014	D0GA102JA023	1/16W 1K	1	
		R53015	D0GA151JA023	1/16W 150	1	
		R53019	D0GB750JA065	1/16W 75	1	
		R54001	D0GAR00J0005	1/16W 0	1	
		R54003	D0GA101JA023	1/16W 100	1	
		R54007	D0GA680JA023	1/16W 68	1	
		R54008	J0JGC0000020	COIL	1	
		R54308	D0GB911JA065	1/16W 910	1	
		R54309	D0GB911JA065	1/16W 910	1	
		R54310	D0GB104JA065	1/16W 100K	1	
		R54311	D0GB104JA065	1/16W 100K	1	
		R55003	D0GA332JA023	1/16W 3.3K	1	
		R55004	D0GA103JA023	1/16W 10K	1	
		R55005	D0GA104JA023	1/16W 0.1U	1	
		R55006	D0GA123JA023	1/16W 12K	1	
		R56101	D0GF1R0JA048	1/2W 1.0	1	
		R56102	D0GF1R0JA048	1/2W 1.0	1	
		R56104	D0GA390JA023	1/16W 47	1	
		R56105	D0GA390JA023	1/16W 47	1	
		R56106	D0GA220JA023	1/16W 56	1	
		R56109	D0GA333JA023	1/16W 33K	1	
		R58001	D0GB4R7JA065	1/16W 4.7	1	
		R58002	D0GA223JA023	1/16W 22K	1	
		R58003	D0GB100JA065	1/16W 22	1	
		R58006	D0GA474JA023	1/16W 470K	1	
		R58007	D0GB223JA065	1/16W 22K	1	
		R58008	D0GA223JA023	1/16W 22K	1	
		R58009	ERJ3RBD472V	1/16W 4.7K	1	
		R58010	ERJ2RHD563X	1/16W 2.2K	1	
		R58011	ERJ2RHD102X	1/16W 1K	1	
		R58012	ERJ2RHD103X	1/16W 10K	1	
		R58014	ERJ2RHD911X	1/16W 910	1	
		R58015	ERJ3RED470V	1/16W 47	1	
		R58016	D0GB330JA065	1/16W 22	1	
		R58017	ERJ2RHD103X	1/16W 10K	1	
		R58020	ERJ2RHD103X	1/16W 10K	1	
		R58023	ERJ3RBD151V	1/16W 150	1	
		R58025	D0GB472JA065	1/16W 4.7K	1	
		R58027	D0GB220JA065	1/16W 22	1	
		R58029	ERJ2RHD103X	1/16W 10K	1	
		R58030	ERJ2RHD333X	1/16W 33K	1	
		R58031	ERJ2RHD223X	1/16W 27K	1	
		R58032	ERJ3RBD331V	1/16W 330	1	
		R58033	D0GA474JA023	1/16W 470K	1	
		R58039	D0GA474JA023	1/16W 470K	1	
		R58046	ERJ3RBD122V	1/16W 1.5K	1	
		R58047	ERJ2RHD393X	1/16W 39K	1	
		R58048	ERJ2RHD103X	1/16W 10K	1	
		R58051	ERJ2RHD183X	1/16W 18K	1	
		R58053	ERJ2RHD152X	1/16W 1.5K	1	
		R58055	ERJ3RBD563V	1/16W 56K	1	
		R58056	ERJ3RBD821V	1/16W 820	1	
		R58057	D0GB330JA065	1/16W 33	1	
		R58067	ERJ3RBD103V	1/16W 10K	1	
		R58110	ERJ2RHD152X	1/16W 1.5K	1	
		R58111	ERJ2RHD183X	1/16W 18K	1	

Model No. : DMR-BWT955GL Parts List

Change	Safety	Ref. No.	Part No.	Part Name & Description	Q'ty	Remarks
		R58112	D0GA474JA023	1/16W 470K	1	
		R58401	ERJ3RBD222V	1/16W 2.2K	1	
		R58402	ERJ3RBD242V	1/16W 2.4K	1	
		R58403	D0GA823JA023	1/16W 82K	1	
		R58404	D0GA473JA023	1/16W 47K	1	
		R58408	D0GB330JA065	1/16W 33	1	
		R58409	ERJ3RBD821V	1/16W 820	1	
		R58410	ERJ3RBD563V	1/16W 56K	1	
		R58411	ERJ3RBD103V	1/16W 10K	1	
		R59003	D0GA330JA023	1/16W 33	1	
		R59004	D0GA680JA023	1/16W 68	1	
		R59005	D0GA121JA023	1/16W 120	1	
		R59011	D0GA330JA023	1/16W 33	1	
		R59013	D0GA680JA023	1/16W 68	1	
		R59014	D0GA102JA023	1/16W 1K	1	
		R59015	D0GA472JA023	1/16W 4.7K	1	
		R59016	D0GA102JA023	1/16W 1K	1	
		R59018	D1BA6491A023	1/16W 6.49K	1	
		R59501	D0GA622JA023	1/16W 6.2K	1	
		R59502	D0GA153JA023	1/16W 15K	1	
		R59503	D0GA102JA023	1/16W 1K	1	
		R59504	D0GA103JA023	1/16W 10K	1	
		R59505	D0GA472JA023	1/16W 4.7K	1	
		R59508	D0GA222JA023	1/16W 2.2K	1	
		R59515	D0GA273JA023	1/16W 27K	1	
		R59516	D0GA221JA023	1/16W 220	1	
		R59517	D0GA473JA023	1/16W 47K	1	
		R59518	D0GA225JA023	1/16W 2.2U	1	
		R59519	D0GA104JA023	1/16W 0.1U	1	
		R59520	D0GA104JA023	1/16W 0.1U	1	
		R59521	D0GA224JA023	1/16W 220K	1	
		R59522	D0GA273JA023	1/16W 27K	1	
		R59547	D0GA474JA023	1/16W 120K	1	
		R59552	D0GA103JA023	1/16W 10K	1	
		R59578	ERJ2RHD333X	1/16W 33K	1	
		R59579	ERJ2RHD223X	1/16W 22K	1	
		R59584	D0GA222JA023	1/16W 2.2K	1	
		R8208	D0GA330JA023	1/16W 33	1	
		R8216	D0GA472JA023	1/16W 4.7K	1	
		R8217	D0GAR00J0005	1/16W 680	1	
		R8218	D0GAR00J0005	1/16W 680	1	
		R8219	D0GAR00J0005	1/16W 0	1	
		R8222	D0GA621JA023	1/16W 620	1	
		R8225	D0GA472JA023	1/16W 4.7K	1	
		R8226	D0GAR00J0005	1/16W 680	1	
		R8227	D0GAR00J0005	1/16W 680	1	
		R8228	D0GAR00J0005	1/16W 680	1	
		R8232	D0GA101JA023	1/16W 100	1	
		R8233	D0GA101JA023	1/16W 100	1	
		R8234	D0GA330JA023	1/16W 33	1	
		R8239	D0GA472JA023	1/16W 4.7K	1	
		R8242	D0GAR00J0005	1/16W 680	1	
		R8243	D0GAR00J0005	1/16W 680	1	
		R8244	D0GA224JA023	1/16W 220K	1	
		R8245	D0GAR00J0005	1/16W 680	1	
		RX51305	D1H85604A042	RESISTOR-RESISTOR	1	
		RX51306	D1H85604A042	RESISTOR-RESISTOR	1	
		RX51307	D1H85604A042	RESISTOR-RESISTOR	1	
		RX51308	D1H85604A042	RESISTOR-RESISTOR	1	
		RX51309	D1H83334A042	RESISTOR-RESISTOR	1	
		RX51310	D1H86824A042	RESISTOR-RESISTOR	1	
		RX51312	D1H84724A042	RESISTOR-RESISTOR	1	

Model No. : DMR-BWT955GL Parts List

Change	Safety	Ref. No.	Part No.	Part Name & Description	Q'ty	Remarks
		RX51313	D1H85604A042	RESISTOR-RESISTOR	1	
		RX51314	D1H84704A042	RESISTOR-RESISTOR	1	
		RX51315	D1H85604A042	RESISTOR-RESISTOR	1	
		RX51316	D1H84704A042	RESISTOR-RESISTOR	1	
		RX51317	D1H86824A042	RESISTOR-RESISTOR	1	
		RX51318	D1H84704A042	RESISTOR-RESISTOR	1	
		RX51319	D1H84704A042	RESISTOR-RESISTOR	1	
		RX51320	D1H83324A042	RESISTOR-RESISTOR	1	
		RX51321	D1H83324A042	RESISTOR-RESISTOR	1	
		RX51322	D1H86824A042	RESISTOR-RESISTOR	1	
		RX53001	D1H84704A042	RESISTOR-RESISTOR	1	
		RX53002	D1H84704A042	RESISTOR-RESISTOR	1	
		RX53003	D1H84704A042	RESISTOR-RESISTOR	1	
		RX54002	D1H83334A042	RESISTOR-RESISTOR	1	
		RX54003	D1H84704A042	RESISTOR-RESISTOR	1	
		RX54004	D1H83034A042	RESISTOR-RESISTOR	1	
		RX54006	D1H86804A042	RESISTOR-RESISTOR	1	
		RX54007	D1H86804A042	RESISTOR-RESISTOR	1	
		RX55001	D1H82224A042	RESISTOR-RESISTOR	1	
		RX55002	D1H81014A042	RESISTOR-RESISTOR	1	
		RX56101	D1H85604A042	RESISTOR-RESISTOR	1	
		RX56102	D1H85604A042	RESISTOR-RESISTOR	1	
		RX56103	D1H83334A042	RESISTOR-RESISTOR	1	
		RX56104	D1H83334A042	RESISTOR-RESISTOR	1	
		RX56105	D1H82204A042	RESISTOR-RESISTOR	1	
		RX56106	D1H81014A042	RESISTOR-RESISTOR	1	
		RX58001	D1H8R0040016	RESISTOR-RESISTOR	1	
		RX59001	D1H81014A042	RESISTOR-RESISTOR	1	
		RX59002	D1H83304A042	RESISTOR-RESISTOR	1	
		RX59003	D1H81014A042	RESISTOR-RESISTOR	1	
		RX59005	D1H83304A042	RESISTOR-RESISTOR	1	
		RX59501	D1H81014A042	RESISTOR-RESISTOR	1	
		RX59504	D1H81014A042	RESISTOR-RESISTOR	1	
		RX59506	D1H84734A042	RESISTOR-RESISTOR	1	
		RX59507	D1H81014A042	RESISTOR-RESISTOR	1	
		RX59508	D1H84734A042	RESISTOR-RESISTOR	1	
		RX59510	D1H81034A042	RESISTOR-RESISTOR	1	
		RX8201	D1H83304A042	RESISTOR-RESISTOR	1	
		RX8202	D1H83304A042	RESISTOR-RESISTOR	1	
		RX8203	D1H83304A042	RESISTOR-RESISTOR	1	
		RX8204	D1H81014A042	RESISTOR-RESISTOR	1	
		RX8205	D1H81014A042	RESISTOR-RESISTOR	1	
		RX8206	D1H81014A042	RESISTOR-RESISTOR	1	
		RX8207	D1H84724A042	RESISTOR-RESISTOR	1	
		RX8208	D1H84724A042	RESISTOR-RESISTOR	1	
		TU8201	J3ABCAC00004	TUNER	1	
		X51201	H0J250500128	CRYSTAL OSCILLATOR	1	
		X59501	H0J100500044	CRYSTAL OSCILLATOR	1	
		X59502	H0J327200230	CRYSTAL OSCILLATOR	1	
		X8201	H0J270500177	CRYSTAL OSCILLATOR	1	
		■	SEP0227AA	HDD BRIDGE P.C.B.		(RTL) E.S.D.
		L20001	J0ZZB0000190	COIL	1	
		P20001	K1KB12AA0063	CONNECTOR (12P)	1	
		P20002	K1KY22A00009	CONNECTOR (22P)	1	
		■	SEP0201AA	FRONT SW P.C.B.		(RTL) E.S.D.
		C7201	F1H1C104A178	16V 0.1U	1	
		C7202	F1H1C104A178	16V 0.1U	1	
		C7203	F1H1C105A167	16V 1U	1	
		D7201	B3AAA0001018	DIODE	1	E.S.D.
		D7202	B3AAA0001018	DIODE	1	E.S.D.
		D7203	B3AAA0001018	DIODE	1	E.S.D.
		DP7201	L5DYAYY00105	LCD DISPLAY	1	

Model No. : DMR-BWT955GL Parts List

Change	Safety	Ref. No.	Part No.	Part Name & Description	Q'ty	Remarks
		IC7201	C0HBA0000317	IC	1	E.S.D.
		IR7201	PNJ4881M01VT	REMOTE SENSOR	1	
		P7201	K1KA10B00176	CONNECTOR(10P)	1	
		QR7201	B1GBCFEN0015	TRANSISTOR	1	E.S.D.
		R7201	D0GD201JA052	1/8W 200	1	
		R7202	D0GD201JA052	1/8W 200	1	
		R7203	D0GD201JA052	1/8W 200	1	
		R7210	D0GD121JA052	1/8W 120	1	
		R7213	D0GB330JA065	1/16W 33	1	
		R7215	D0GBR00J0004	1/16W 0	1	
		S7201	EVQ11A05R	SWITCH (PLAY)	1	
		S7202	EVQ11A05R	SWITCH (PLAY)	1	
		W502	D0GFR00J0005	1/2W 0	1	
		W503	D0GFR00J0005	1/2W 0	1	
		W504	D0GBR00J0004	1/16W 0	1	
		W505	D0GBR00J0004	1/16W 0	1	
		W506	D0GDR00J0004	1/8W 0	1	
		W507	D0GFR00J0005	1/2W 0	1	
		W508	D0GBR00J0004	1/16W 0	1	
		ZB7201	RMN0960	LCD SPACER	1	

Model No. : DMR-BWT955GL Exploded View

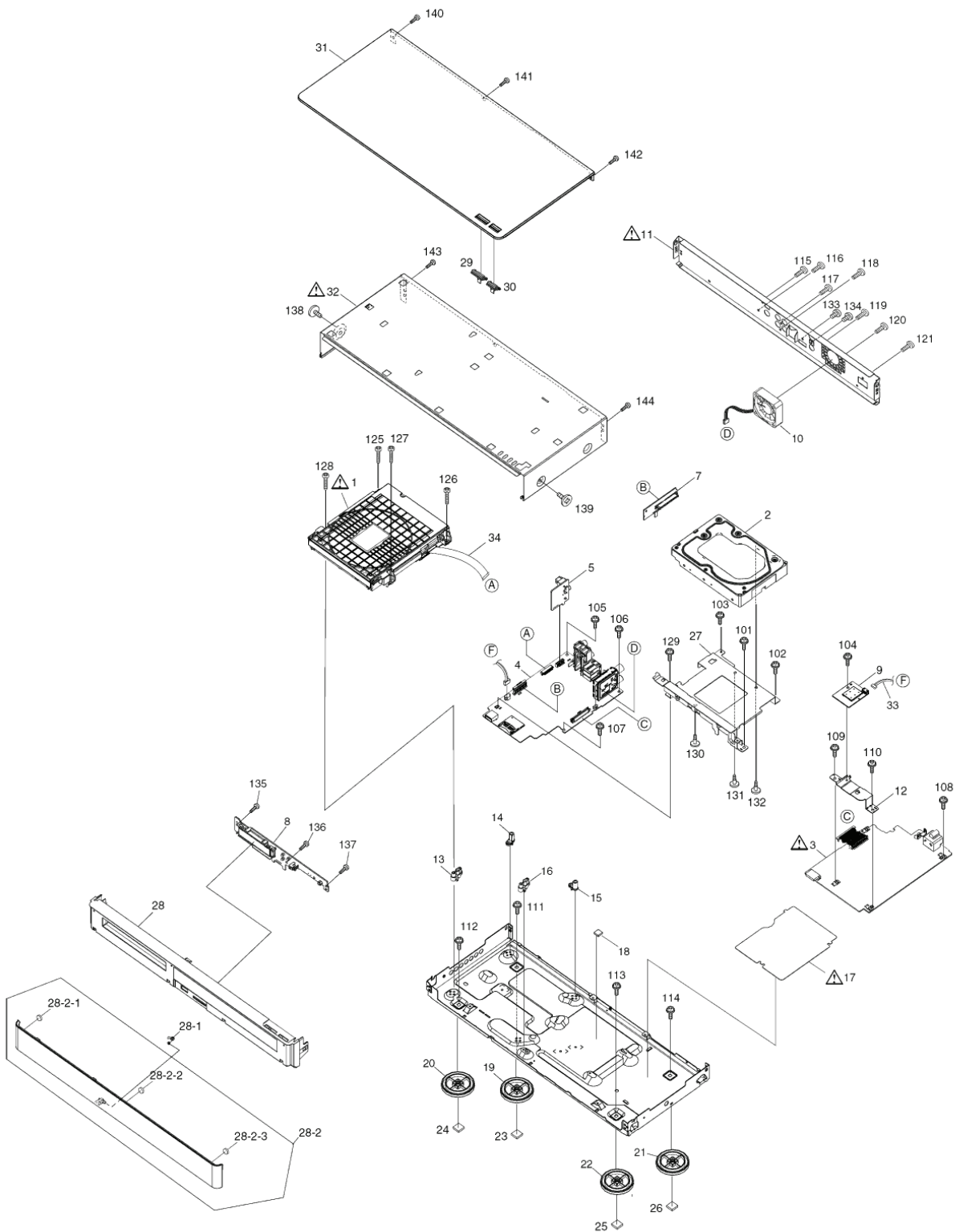

Model No. : DMR-BWT955GL Mechanism View

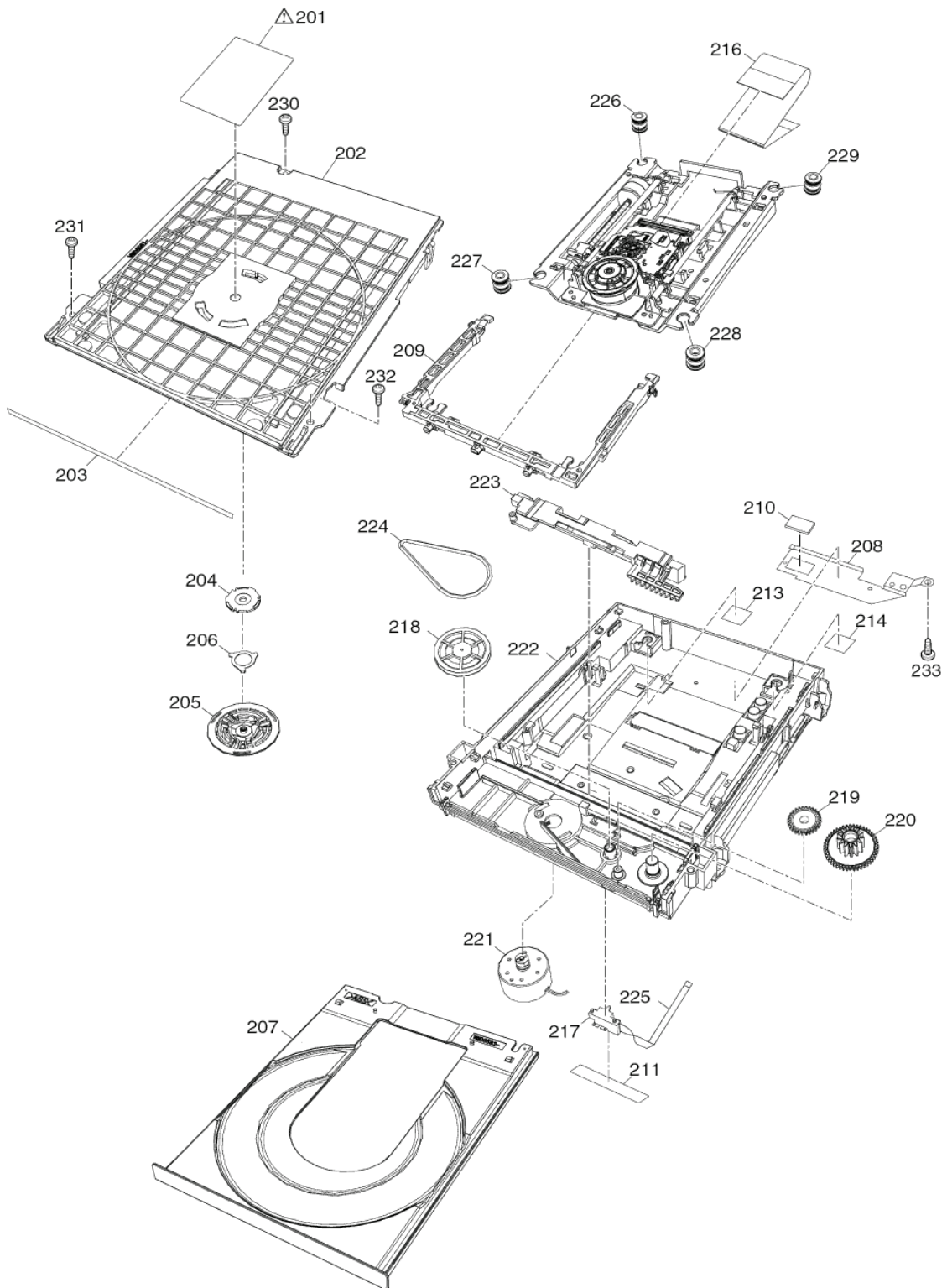

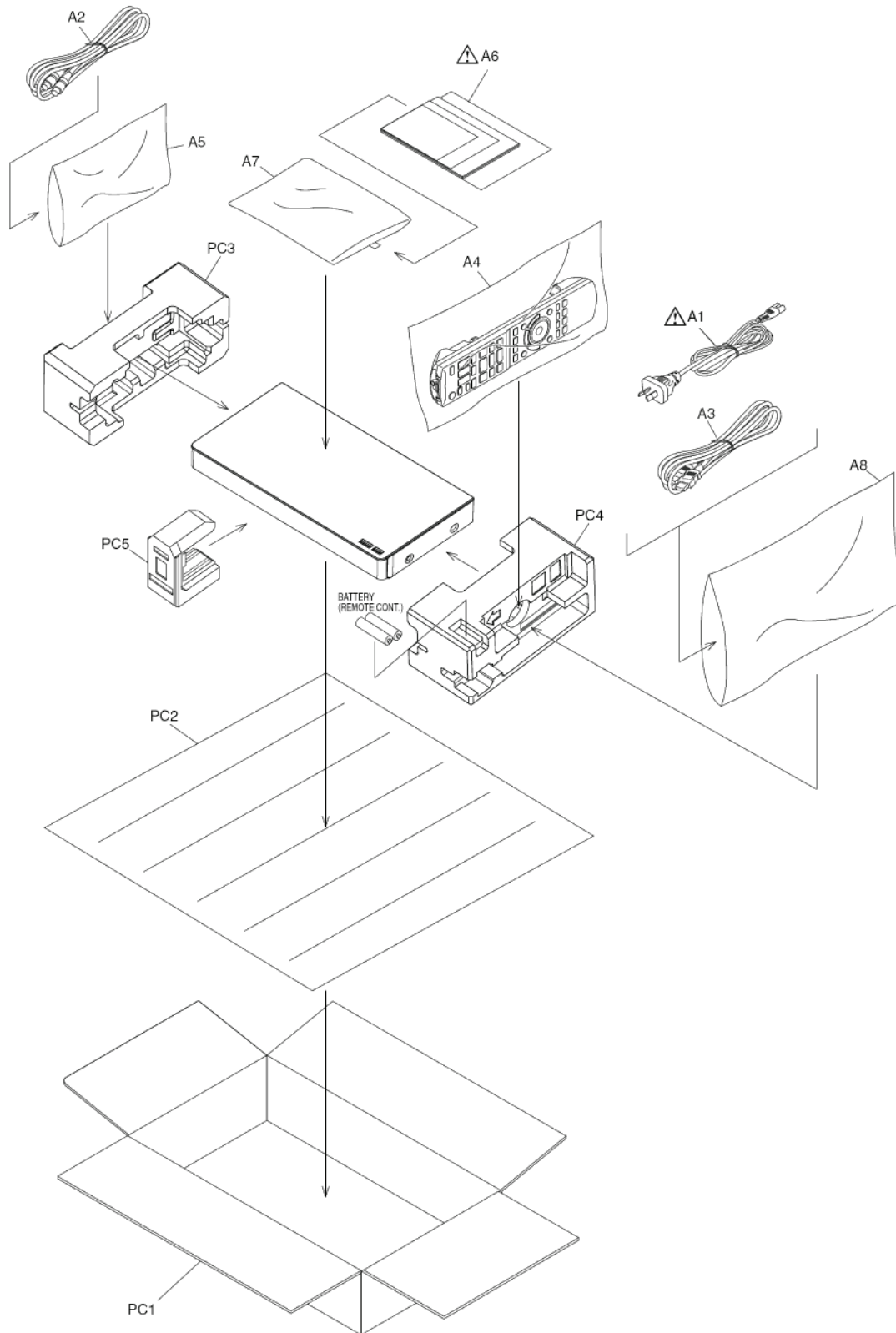

Model No. : DMR-BWT955GL Packing View



Model No. : DMR-BWT955GL Parts List

Change	Safety	Ref. No.	Part No.	Part Name & Description	Q'ty	Remarks
			■	CASING		
	⚠	1	SXY0018	BD DRIVE	1	
		2	SUCV0034HDKT	HDD	1	
	⚠	3	SEP0199AA	MAIN P.C.B.	1	(RTL) E.S.D.
		4	SUKB0226AB	DIGITAL P.C.B.	1	E.S.D.
		5	SUKB0200AB	D-AUDIO P.C.B.	1	(RTL) E.S.D.
		7	SEP0227AA	HDD BRIDGE P.C.B.	1	(RTL) E.S.D.
		8	SEP0201AA	OPERATION P.C.B.	1	(RTL) E.S.D.
		9	C5ZZZ0000088	WIFI MODULE	1	(RTL) E.S.D.
		10	L6FAYYYG0007	DC FAN	1	
	⚠	11	RGR0458N-A1	REAR PANEL	1	
		12	RMA2518-1	WIFI SPACER	1	
		13	RMX0486	DRIVE SPACER	1	
		14	RMX0486	DRIVE SPACER	1	
		15	RMX0519	DRIVE SPACER	1	
		16	RMX0519	DRIVE SPACER	1	
	⚠	17	RMZ1499	INSULATION SHEET	1	
		18	RSC0905	RADIATOR SHEET	1	
		19	RKA0228B-K	FOOT A	1	
		20	RKA0228B-K	FOOT A	1	
		21	RKA0228A-K	FOOT B	1	
		22	RKA0228A-K	FOOT B	1	
		23	RMG0771-K	FOOT RUBBER	1	
		24	RMG0771-K	FOOT RUBBER	1	
		25	RMG0771-K	FOOT RUBBER	1	
		26	RMG0771-K	FOOT RUBBER	1	
		27	RMA2482-3	HDD SPACER	1	
		28	RYP2043A-S	FRONT PANEL ASS'Y	1	
		28-1	RMB0943	SPRING	1	
		28-2	RYF1003A-Q	DOOR ASS'Y	1	
		28-2-1	RMG0849-K	DOOR DAMPER	1	
		28-2-2	RMG0849-K	DOOR DAMPER	1	
		28-2-3	RMG0849-K	DOOR DAMPER	1	
		29	RGU2958A-K	POWER BUTTON	1	
		30	RGU2959A-K	OPEN/CLOSE BUTTON	1	
		31	SUKN000005	TOP ORNAMENT (COVER) ASS'Y	1	
	⚠	32	RKM0624B-S	TOP CASE	1	
		33	SEE0069	WLAN CABLE	1	
		34	STJ0047	BD POWER FFC	1	
		101	RHD30111-31	SCREW	1	
		102	RHD30111-31	SCREW	1	
		103	RHD30111-31	SCREW	1	
		104	RHD30111-31	SCREW	1	
		105	RHD30111-31	SCREW	1	
		106	RHD30111-31	SCREW	1	
		107	RHD30111-31	SCREW	1	
		108	RHD30111-31	SCREW	1	
		109	RHD30111-31	SCREW	1	
		110	RHD30111-31	SCREW	1	
		111	RHD30111-31	SCREW	1	
		112	RHD30111-31	SCREW	1	
		113	RHD30111-31	SCREW	1	
		114	RHD30111-31	SCREW	1	
		115	RHD30119-L	SCREW	1	
		116	RHD30119-L	SCREW	1	
		117	RHD30119-L	SCREW	1	
		118	RHD30119-L	SCREW	1	
		119	RHD30119-L	SCREW	1	
		120	RHD30119-L	SCREW	1	
		121	RHD30119-L	SCREW	1	
		125	RHD30183	SCREW	1	
		126	RHD30183	SCREW	1	

Model No. : DMR-BWT955GL Parts List

Change	Safety	Ref. No.	Part No.	Part Name & Description	Q'ty	Remarks
		127	RHD30183	SCREW	1	
		128	RHD30183	SCREW	1	
		129	RHD30161-1	SCREW	1	
		130	RHD30161-1	SCREW	1	
		131	RHD30161-1	SCREW	1	
		132	RHD30161-1	SCREW	1	
		133	XSN3+4FJ	SCREW	1	
		134	XSN3+4FJ	SCREW	1	
		135	RHD26045-J	SCREW	1	
		136	RHD26045-J	SCREW	1	
		137	RHD26045-J	SCREW	1	
		138	RHD30113	SCREW	1	
		139	RHD30113	SCREW	1	
		140	XTB3+8JFJ	SCREW	1	
		141	XTB3+8JFJ	SCREW	1	
		142	XTB3+8JFJ	SCREW	1	
		143	XTB3+8JFJ	SCREW	1	
		144	XTB3+8JFJ	SCREW	1	
		201	VQL2Q40	LASER CAUTION LABEL	1	
		202	VMD6581-6	UPPER BASE	1	
		203	VMT2257	DUST SHEET	1	
		204	VMA0Y49	YOKE	1	
		205	VMD6582-2	CLAMPER	1	
		206	VMG2026	CLAMP COVER	1	
		207	VMD6583-1	TRAY	1	
		208	VMA0Y47	HEAT SINK	1	
		209	VMD6587-5	MID BASE	1	
		210	VMG1694	HEAT SINK RUBBER	1	
		211	VMT2258	DUST CUSHION A	1	
		213	VMZ3930	DUST SHEET A	1	
		214	VMZ3930	DUST SHEET A	1	
		216	VMJ2477	OPU FFC	1	
		217	K0L1CE000001	SWITCH	1	
		218	VDG1774	PULLEY GEAR	1	
		219	VDG1775	MID GEAR	1	
		220	VDG1776	DRIVE GEAR	1	
		221	VEM0897	LOADING MOTOR U	1	
		222	VMD6951-2	MECHA CHASSIS	1	
		223	VMD6585-2	SLIDE CAM	1	
		224	VMG1720	BELT	1	
		225	VMJ2317	SWITCH FFC	1	
		226	VMG2027	DAMPER	1	
		227	VMG2027	DAMPER	1	
		228	VMG2027	DAMPER	1	
		229	VMG2027	DAMPER	1	
		230	XTV26+10GFJ	SCREW	1	
		231	XTV26+10GFJ	SCREW	1	
		232	XTV26+10GFJ	SCREW	1	
		233	XTV26+10GFJ	SCREW	1	
			■	ACCESSORY		
		A1	K2CJ2YY00101	AC CORD	1	
		A2	K1TYYYY00056	COAXIAL CABLE	1	
		A3	K1HY19YY0011	HDMI CABLE	1	
		A4	N2QAYB001039	REMOTE CONTROL ASS'Y	1	
		A5	RPPC0119-1	POLYETHYLENE BAG	1	
		A6	SQT0801-1	OPERATING INSTRUCTIONS	1	
		A7	RPF0703	POLYETHYLENE BAG	1	
		A8	RPF0703	POLYETHYLENE BAG	1	
			■	PACKING		
		PC1	SPU0064	PACKING CASE	1	
		PC2	RPF0739	POLYETHYLENE BAG	1	
		PC3	RPN2708A	CUSHION (A)	1	

Model No. : DMR-BWT955GL Parts List

Change	Safety	Ref. No.	Part No.	Part Name & Description	Q'ty	Remarks
		PC4	RPN2708B	CUSHION(B)	1	
		PC5	RPN2709	FRONT CUSHION	1	