

## SERVICE BULLETIN REFRIGERATOR







**MODEL:** SJ244VWH, SJ308VSL, SJ308VWH, SJ339VSL, SJ339VWH.

**SUBJECT:** Change of connector for AC/DC fan motor.

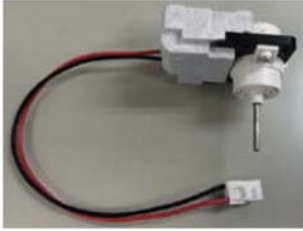
**GENERAL:** We decided to change connector of the AC/DC fan motor to eliminate possibility of wrong motor installed due to human error.

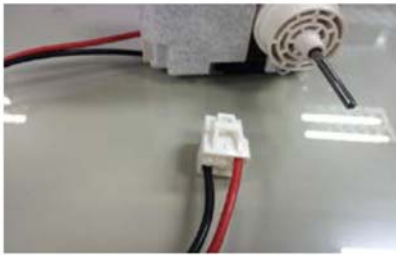
**ACTION:** Please refer to below to differentiate between old fan motor (RMOTRA136CBZZ) and the new fan (RMOTRA161CBZZ).

Ref	Description	Part Code		Qty	Price code
		OLD	NEW		
1-14	Fan motor	RMOTRA136CBZZ	RMOTRA161CBZZ	1	BA
	Connector pin	6 pin	8 pin		

DIFFERENTIATE	RMOTRA136CBZZ (OLD)	RMOTRA161CBZZ (NEW)
APPERANCE		
CONNECTOR		
TAG		

**PRODUCTION CHANGE:** Various depend on model.

**Case 1:** If the faulty fridge used the 6 pin connector, please reuse the 6 pin connector from the faulty fan as per procedure below

- a) Please take off F-Shelf, ice cube maker and ice cube box from cabinet.



- b) Remove F-louver screws, position as below picture.

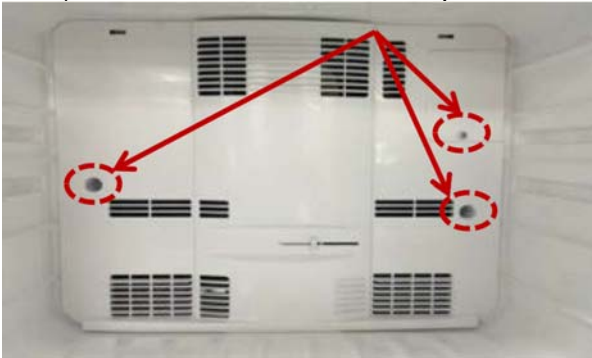

- c) Please disconnect the Def-thermistor, Fuse Ass'y and fan motor connectors from F-Room to take off F-Louver ass'y prior replacing new fan motor.
- d) Carefully take off the fan cables 3 (red) and 4 (black) from the 6 pin sockets. **Please refer to Appendix A on how to remove these sockets.**

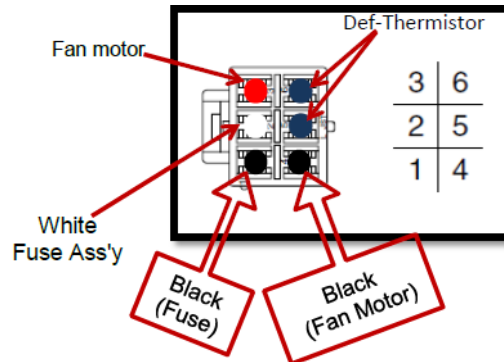

- e) Carefully take off the fan cables from the socket of the fan motor RMOTRA161CBZZ.

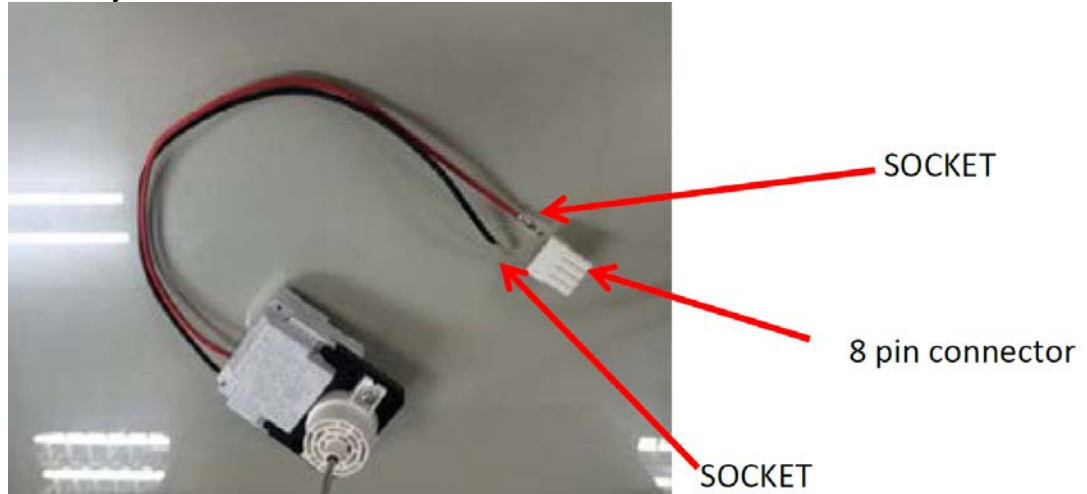

- f) Insert new fan motor (RMOTRA161CBZZ) cable in step e) to connector in step d). Note red to pin 3 and black to pin 4.



- g) Checking defrost thermistor as per Appendix B.
- h) Checking thermo fuse by using the DVM to check if there is short circuit between pin 1 and 2.
- i) Assemble the unit in the reverse order then proceed to the common procedure j).

**Case 2:** If the faulty fridge used the 8 pin connector, please use the new 8 pin connector as per procedure below

a) Please take off F-Shelf, ice cube maker and ice cube box from cabinet.



b) Remove F-louver screws, position as below picture.

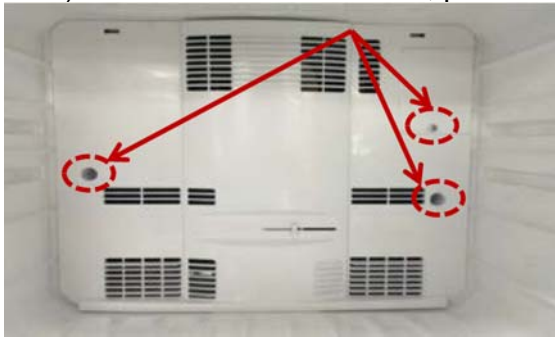

c) Please disconnect the Def-thermistor, Fuse Ass'y and fan motor connectors from F-Room to take off F-Louver ass'y prior replacing new fan motor.

d) Carefully take off Def thermistor cables 6 (blue) & 7 (blue) from the old 8 pin socket. Please refer to Appendix A on how to remove these sockets.

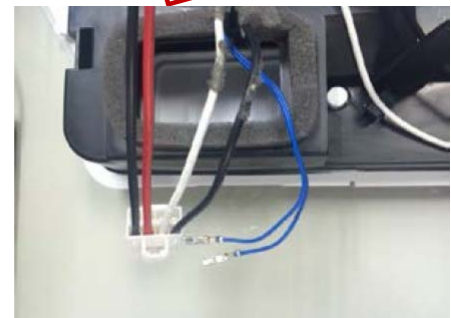
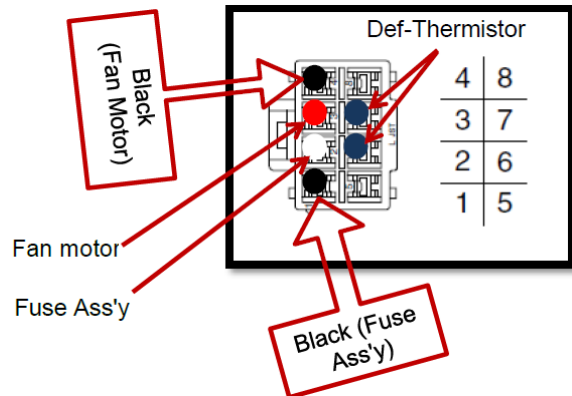

- e) Carefully take off the fuse cables 1 (black) & 2 (white) from the old 8 pin socket.  
Please refer to Appendix A on how to remove these pins.

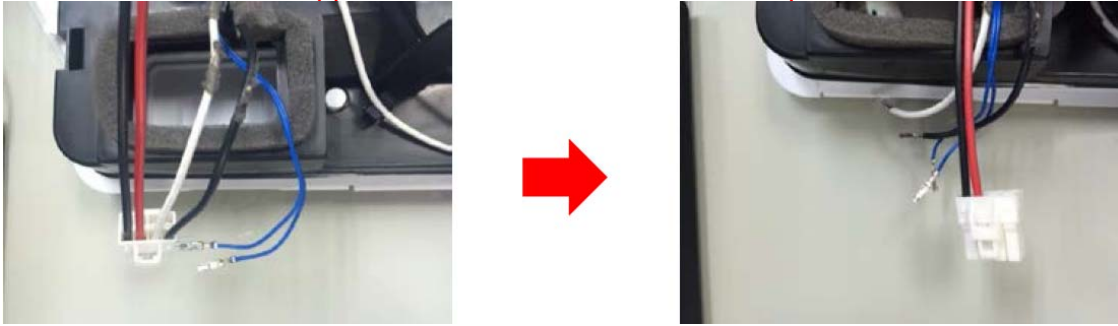

- f) Please insert the Def thermistor and fuse cables in step d) and e) to the new fan motor socket RMOTRA161CBZZ.



- g) Checking defrost thermistor as per Appendix B.
- h) Checking thermo fuse by using the DVM to check if there is short circuit between pin 1 and 2.
- i) Assemble the unit in the reverse order then proceed to the common procedure j)

## COMMON PROCEDURE TO CHECK IF THE FAN IS WORKING

- j) Turn on the power of the fridge and check the air flow of the new fan. If there is no air flow then check for incorrect assemble of the fan socket. **Note if the refrigerator was power off for less than 6 minute then the compressor may be in lock mode hence the fan may not operate.**



## APPENDIX A: How to remove the socket from fan connector

Normally, the socket is lock by the connector lance as below picture

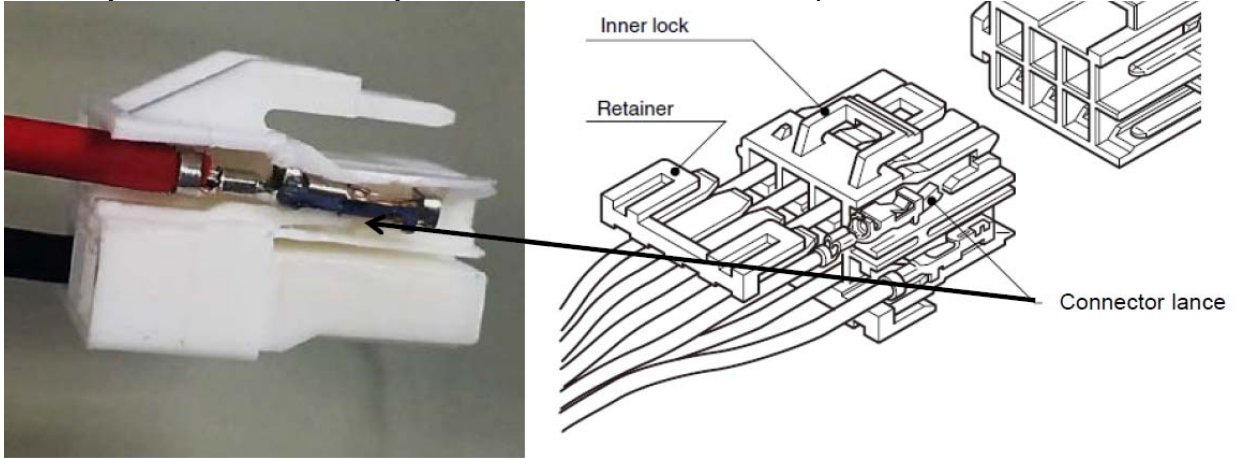

So in order to remove the socket you need a needle or brooch similar to below



Simultaneously use a needle to press on connector lance in opposite direction of socket and pull the wire at the same time

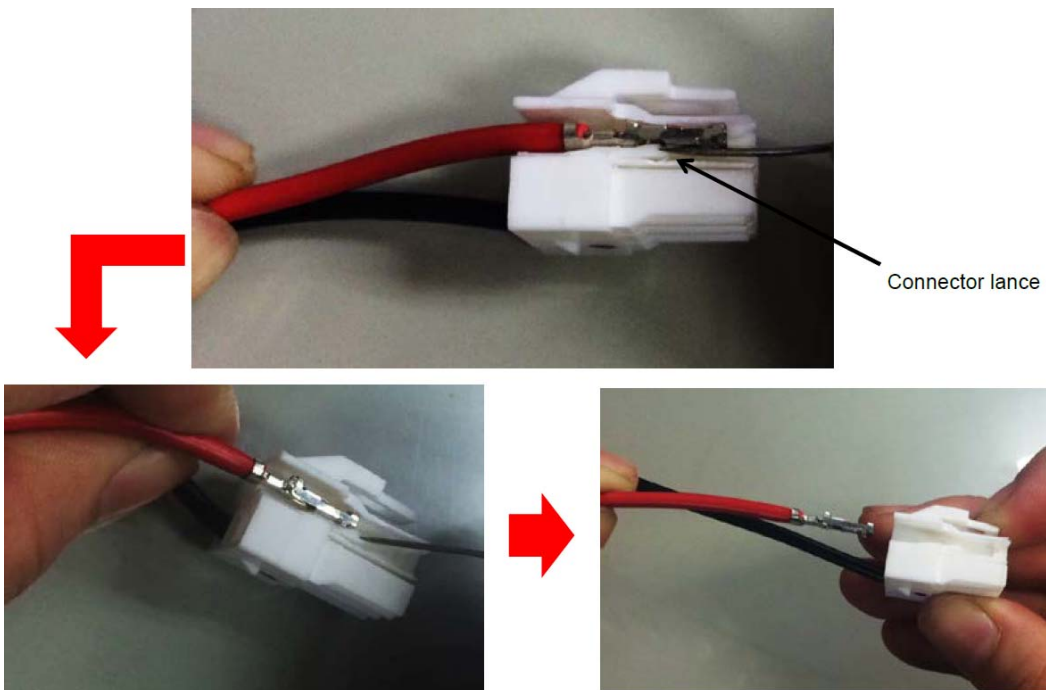

## APPENDIX B: Checking defrost thermistor and its connection

Using the multi-meter measure whether the temperature resistance value of defrost thermistor is correct as per conversion table below. Please disconnect the connector “CN3” on the PWB and measure the resistance value between pin 3 and 4 as per below.

[2] ELECTRIC ACCESSORIES LAYOUT

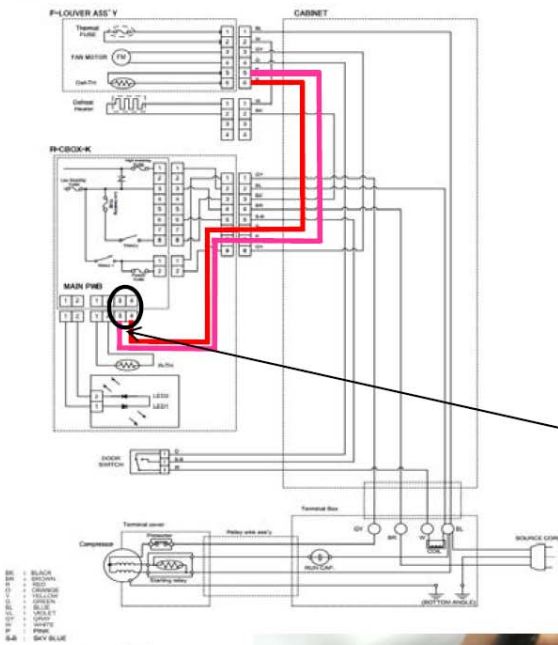

Measurement point



Checking temperature of def-

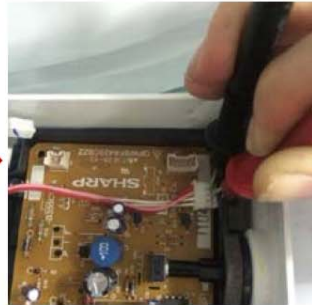

check resistance from pin 3 and 4 at CN3



Check correction between temperature and resistance with conversion table



Conversion table between Def-thermistor Temperature and Resistance Value  $R(0^{\circ}\text{C}) = 6.400 \text{ k}\Omega \pm 1.5 \%$

Temperature (°C)	Resistance value (kΩ)	Temperature (°C)	Resistance value (kΩ)	Temperature (°C)	Resistance value (kΩ)	Temperature (°C)	Resistance value (kΩ)	Temperature (°C)	Resistance value (kΩ)
1	6.0800	11	3.7060	21	2.3290	31	1.5050	41	0.9985
2	5.7780	12	3.5330	22	2.2270	32	1.4430	42	0.9596
3	5.4930	13	3.3690	23	2.1300	33	1.3840	43	0.9225
4	5.2230	14	3.2140	24	2.0370	34	1.3270	44	0.887
5	4.9680	15	3.0660	25	1.9490	35	1.2740	45	0.8531
6	4.7280	16	2.9270	26	1.8660	36	1.2220	46	0.8206
7	4.5000	17	2.7950	27	1.7870	37	1.1730	47	0.7896
8	4.2850	18	2.6690	28	1.7110	38	1.1260	48	0.7599
9	3.9840	19	2.5500	29	1.6390	39	1.0820	49	0.7315
10	3.8880	20	2.4360	30	1.5710	40	1.0390	50	0.7043