



**ELECTROLUX HOME PRODUCTS PTY LTD**  
ABN 51 004 762 341

Technical Publication N° DW225

Issue: 4  
Date: 01/11

**WEB SITE ADDRESS: [www.partnship.com.au](http://www.partnship.com.au)**

# ***ELECTROLUX***

## ***HOUSEHOLD DISHWASHER***

**TO BE USED IN CONJUNCTION WITH  
CIRCUIT and WIRING DIAGRAM PUBLICATION - DW230.**

***MODEL ESL66010B IS USED BY THE SALES  
DEPARTMENT ONLY.***

***DWEB001 Integrated Door Panel Kit, is sold with the  
ESL66010 to create the new model, therefore the PNC  
is the same for BOTH models.***

**MODEL:  
ESL66010 and ESL66010B  
PNC 911936254 00**

<b>VARIANT CHANGE SUMMARY</b>	
<b>00</b>	INTRODUCTION

<b>Release Date:</b>	
ESL66010/91193625400	01/10/2009
ESL66010B/91193625400	01/11/2009

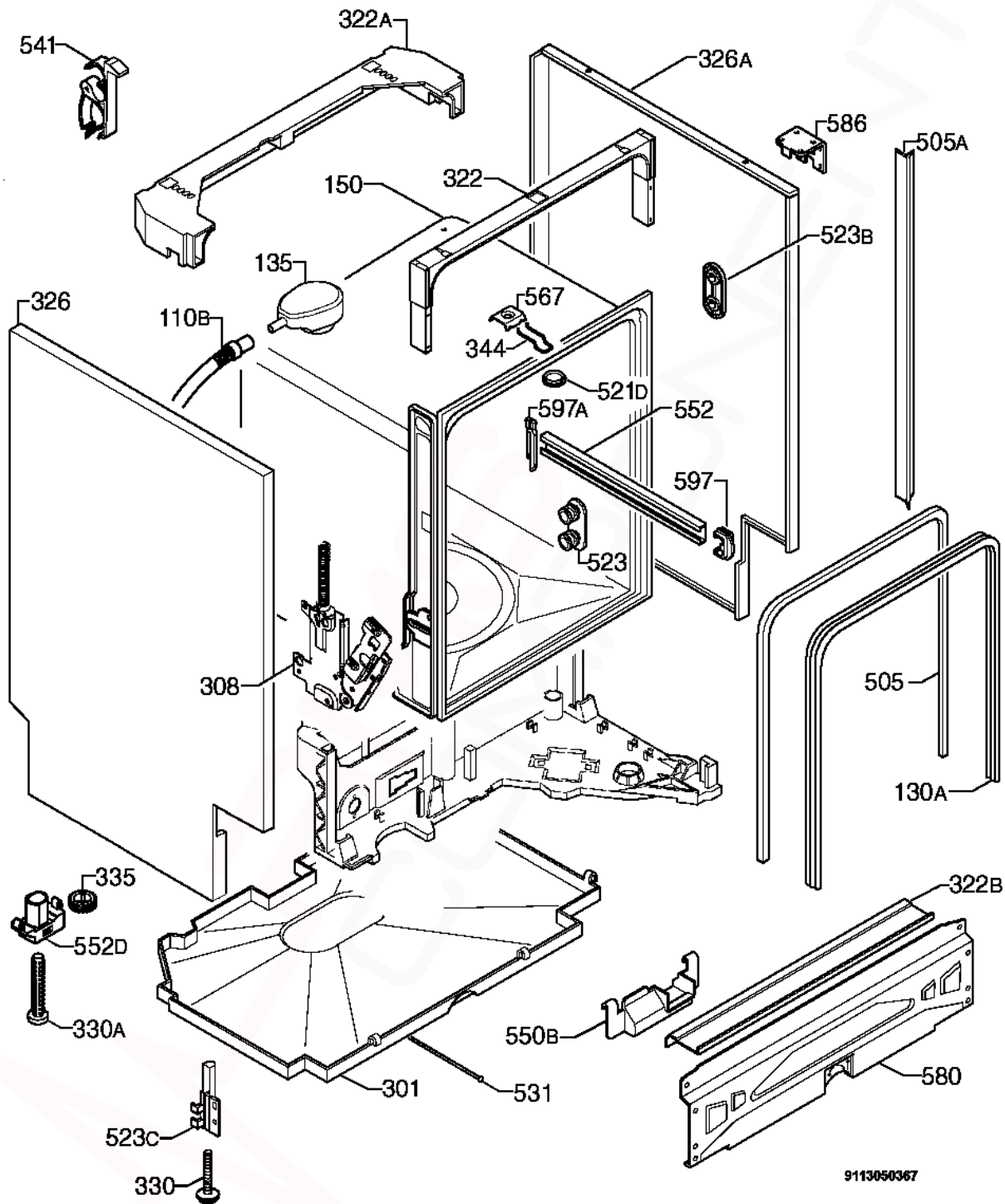

ITEM	PART N°	DESCRIPTION Ex. 9113050367	QTY
110B	1527937-01/3	Tube Drying x 680mm Long	1
130A	1171265026	Sealing Outer x 1730mm Long	1
135	1171458118	Air Guide ACTIVE DRYING	1
150	N.P.A.	Tub	-
301	1526298-07/8	Bottom Cabinet	1
308	4055031548	Kit Door Hinge Right-Left	1
322	1525280507	Crossbar Front Zinc-Plated	1
322A	1170350-01/9	Crossbar Back Upper	1
322B	1527256-10/9	Crossbar Front Bottom	1
326	4055047197	Side Panel Left Zinc-Plated	1
326A	4055047205	Side Panel Right Zinc-Plated	1
330	1526617-02/0	Adjustable Foot Front	2
330A	1526994-00/7	Adjustable Foot Central	1
335	1527142-00/2	Cog Wheel	1
344	1522344-05/8	Latch	1
505	1526715-40/2	Trimming Tub Black x 1710mm Long	1
505A	1522222-40/3	Trimming Side x 592mm Long	2
521D	1526576-00/2	Hole Cover Latch	1
523	50299970009	Wheel Support Kit Dark Grey (4 Pieces)	1
523B	1521220-10/1	Stiffening Holder Roller	4
523C	1526315-03/9	Foot Support Front Left	1
523C	1526315-13/8	Foot Support Front Right	1
531	1170685-00/0	Adjusting Screw Foot Central	1
541	1526417-00/9	Hose Clamp	1
550B	1522345-03/0	Wiring Protection	1
552	1170542-00/3	Rail Basket Upper	2
552D	1523698-06/4	Guidance Rail Foot Central	1
567	1523236-03/0	Plaque (Speed Clip)	1
580	50290285-00/1	Enclosure Front Bottom	1
586	1170209-00/9	Fixing Bracket Top	2
597	1520479-30/2	Basket Stop Front Dark Grey	2
597A	8996461234-05/7	Stopper Back Dark Grey	2
N.I.	4055046587	Fixing Clip Stud (4 Pieces)	1
N.I.	ES6060	Foil Aluminium Adhesive	1

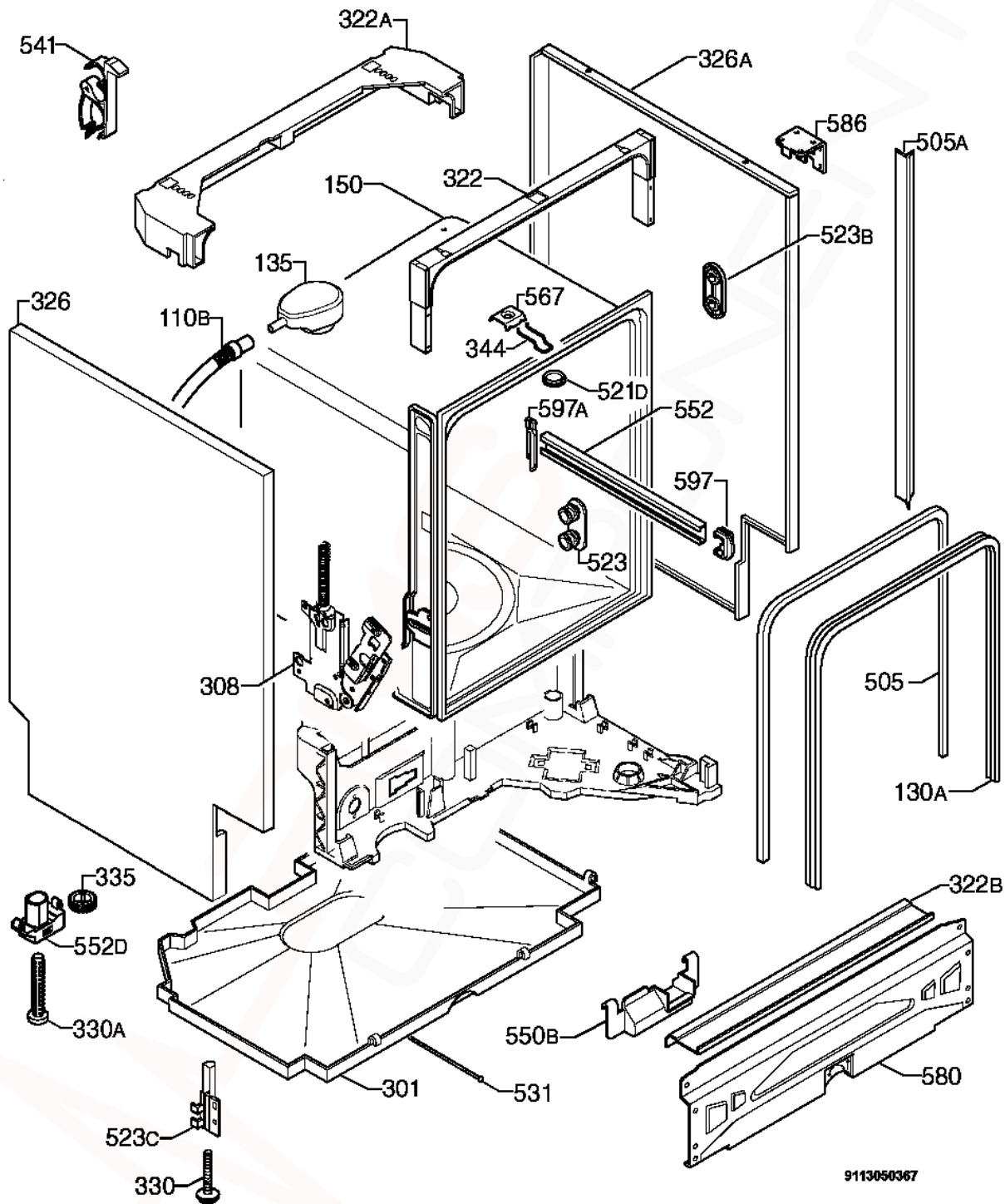

ITEM	PART N°	DESCRIPTION Ex. 9113050367	QTY
110B	1527937-01/3	Tube Drying x 680mm Long	1
130A	1171265026	Sealing Outer x 1730mm Long	1
135	1171458118	Air Guide ACTIVE DRYING	1
150	N.P.A.	Tub	-
301	1526298-07/8	Bottom Cabinet	1
308	4055067948	Kit Door Hinge Right-Left 'HEAVY" (single fulcrum)	1
322	1525280507	Crossbar Front Zinc-Plated	1
322A	1170350-01/9	Crossbar Back Upper	1
322B	1527256-10/9	Crossbar Front Bottom	1
326	4055047197	Side Panel Left Zinc-Plated	1
326A	4055047205	Side Panel Right Zinc-Plated	1
330	1526617-02/0	Adjustable Foot Front	2
330A	1526994-00/7	Adjustable Foot Central	1
335	1527142-00/2	Cog Wheel	1
344	1522344-05/8	Latch	1
505	1526715-40/2	Trimming Tub Black x 1710mm Long	1
505A	1522222-40/3	Trimming Side x 592mm Long	2
521D	1526576-00/2	Hole Cover Latch	1
523	50299970009	Wheel Support Kit Dark Grey (4 Pieces)	1
523B	1521220-10/1	Stiffening Holder Roller	4
523C	1526315-03/9	Foot Support Front Left	1
523C	1526315-13/8	Foot Support Front Right	1
531	1170685-00/0	Adjusting Screw Foot Central	1
541	1526417-00/9	Hose Clamp	1
550B	1522345-03/0	Wiring Protection	1
552	1170542-00/3	Rail Basket Upper	2
552D	1523698-06/4	Guidance Rail Foot Central	1
567	1523236-03/0	Plaque (Speed Clip)	1
580	50290285-00/1	Enclosure Front Bottom	1
586	1170209-00/9	Fixing Bracket Top	2
597	1520479-30/2	Basket Stop Front Dark Grey	2
597A	8996461234-05/7	Stopper Back Dark Grey	2
N.I.	4055046587	Fixing Clip Stud (4 Pieces)	1
N.I.	ES6060	Foil Aluminium Adhesive	1

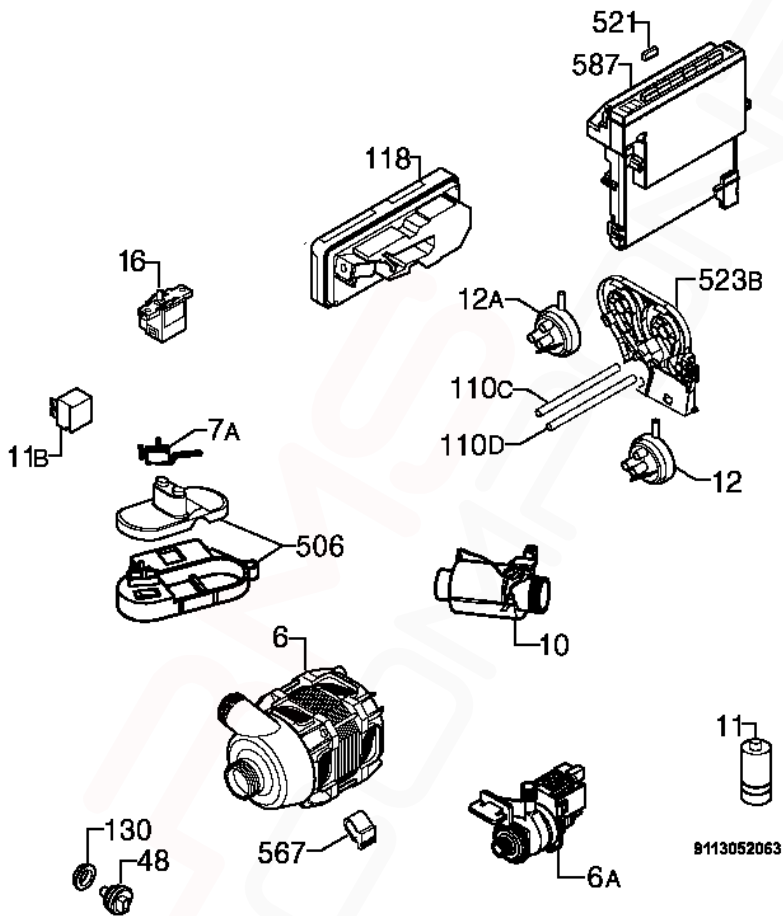

8113052063

**MODELS: ESL66010  
ESL66010B**

**PNC 911936254 00  
PNC 911936254 00**

**EX. VIEW 9113052063  
ELECTRICAL COMPONENTS**

ITEM	PART N°	DESCRIPTION Ex. 9113052063	QTY
6	50299965009	Washing Motor Tachometric 2800 RPM	1
6A	1528261-02/5	Drain Pump Reworked 50H	1
7A	1520393-11/5	Microswitch Anti-Overflow	1
10	50297618-00/6	Heating Element 230V/2000W Ø32mm	1
11	50287485-00/2	Running Capacitor Shank	1
11B	0144400042	Interference Suppressor	1
12	1528189-02/8	Pressure Switch Level 65/45	1
12A	1528189-12/7	Pressure Switch Safety 123/98	1
16	1111433-00/7	Main Switch (O/I)	1
48	1113160004	Temperature Sensor Turbidity Sensor	1
110C	1170450-40/5	Tube Pressure Switch Safety x 515mm Long	1
110D	1170450-51/2	Tube Pressure Switch Level x 525mm Long	1
118	1113330128	Detergent Dispenser C/R	1
130	0208400152	Sealing Sleeve Temperature Sensor	1
506	50297120-00/3	Kit Support Float	1
523B	1526601-30/5	Cover Cap Keyboard Silver	1
535	1170351-00/9	Mount Pressure Switch	1
567	1171934019	Motor Bracket Buffer	1
587	973911936254003	Configured Electronic EDW1503	1
N.I.	1170598-00/5	Sponge Drain Pump "L"	
N.I.	1170862-31/0	Power Cable AUS/NZ	1
N.I.	1527921801	Harness Complete	1
N.I.	1526491-01/2	Electric Cable Anti-Overflow Gasket	1



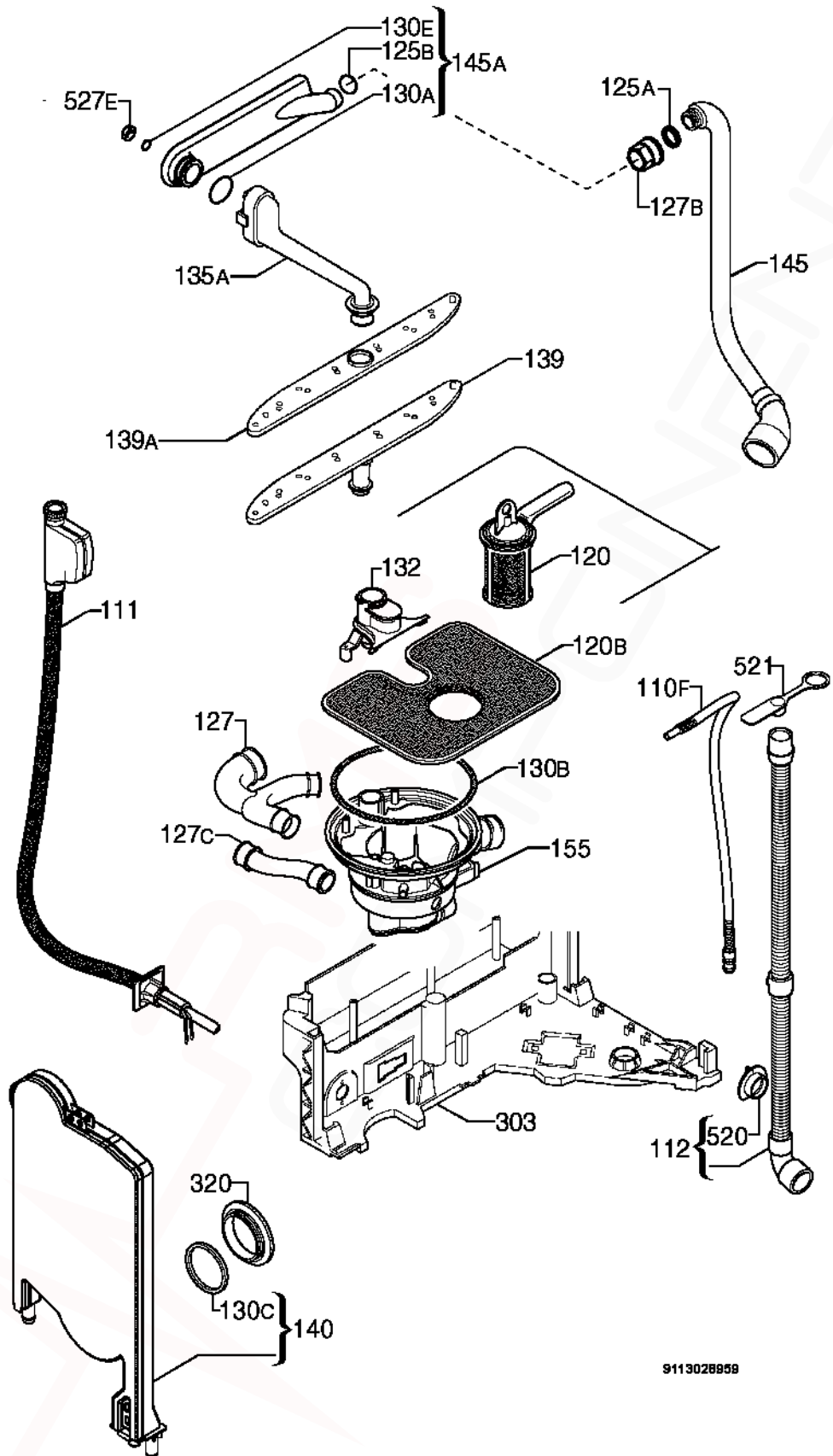

**MODELS: ESL66010  
ESL66010B**

**PNC 911936254 00  
PNC 911936254 00**

**EX. VIEW 9113028959  
SUMP, PUMP and  
HYDRAULICS SYSTEM**

ITEM	PART N°	DESCRIPTION Ex. VIEW 9113028959	QTY
110F	1118698305	Ventilating Tube Install Column x 1477mm Long	1
111	50295662-00/6	Inlet Hose Water Block x 1500mm Long	1
112	1527820011	Discharge Hose Install Column x 2250mm Long	1
120	50297774-00/7	Drain Filter Complete Light Grey	1
120B	1524360-00/3	Filter Inox	1
125A	50282650-00/6	O-Ring Manifold Outer	1
125B	50227938-00/3	O-Ring Manifold Inner	1
127	1118796208	Pipe Union Y	1
127B	1523118-20/4	Pipe Union Manifold Dark Grey	1
127C	1526716-01/2	Pipe Union Decalcifier Sump	1
130A	1523119-01/2	Seal Channel Drainage	1
130B	0208400147	O-Ring Sump	1
130C	50659231-00/0	Round Seal Container Cup	1
130E	1522802-00/6	Sealing Strip	1
132	1118495-91/8	Column Support Lower Spray Arm	1
135A	1526687-52/8	Channel Drainage Dark Grey Complete	1
139	1526523-40/0	Lower Spray Arm Dark Grey	1
139A	1526520-30/7	Spray Arm Upper Dark Grey	1
140	1170481-00/4	Container Cup Small Electronic	1
145	1528059-00/7	Manifold Outer Ø32mm	1
145A	1172023-01/0	Manifold Horizontal Dark Grey	1
155	1527957128	Sump Pipe Union Complete	1
303	1526292204	Basement	1
320	1526272-10/7	Grill Vapour Outlet Dark Grey	1
520	1526862-00/6	Flange Discharge Pipe	1
521	1527389-00/9	Stopper Drainage Hose	1
527E	50286080-00/2	Nut Water Distributor	1
N.I.	1529175109	Fixing Clamp Sensor 35.6mm	1
N.I.	4055034963	Service Kit Electric Cable Sensor	-

If a Customer needs to extend their Drain Hose, order the following components:  
0571400142 Hose Drain (2M length), 0182200002 Ferrule Hose Joiner (19mm)  
and 2 x 0005001019 Clamp.

For extensions less than 2 metres, use ES5323K Kit Hose Flex Drain (1M)

**NOTE:** Total Drain Hose length must not exceed 4 metres.

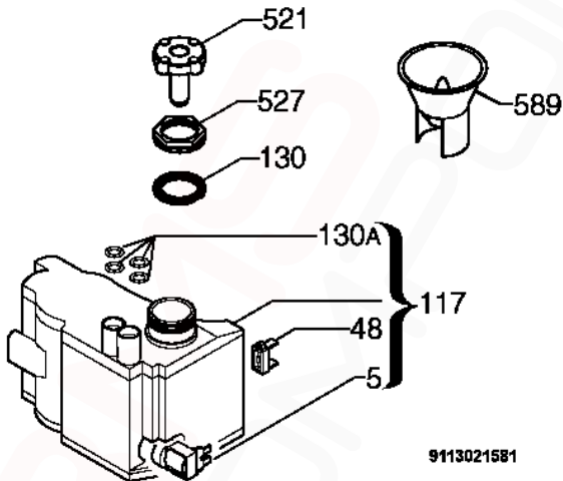

9113021581

9113021581

**MODELS: ESL66010  
ESL66010B**

**PNC 911936254 00  
PNC 911936254 00**

**EX. VIEW 9113021581  
REGENERATION TANK  
ASSEMBLY**

<b>ITEM</b>	<b>PART N°</b>	<b>DESCRIPTION</b>	<b>Ex. VIEW 9113021581</b>	<b>QTY</b>
5	<b>1528765-01/7</b>	Regeneration Electric Valve Water Softener		1
48	<b>1528882-01/0</b>	Salt Sensor Decalcifier		1
117	<b>50286081-00/0</b>	Decalcifier		1
130	<b>1521128-10/6</b>	Gasket Decalcifier		1
130A	<b>1526505-00/1</b>	Grommet Decalcifier		4
521	<b>1526411-00/2</b>	Stopple Decalcifier		1
527	<b>1526449-10/1</b>	Ring Nut Decalcifier Dark Grey		1
589	<b>1172107300</b>	Filling Funnel Dishwasher Salt Transparent		1

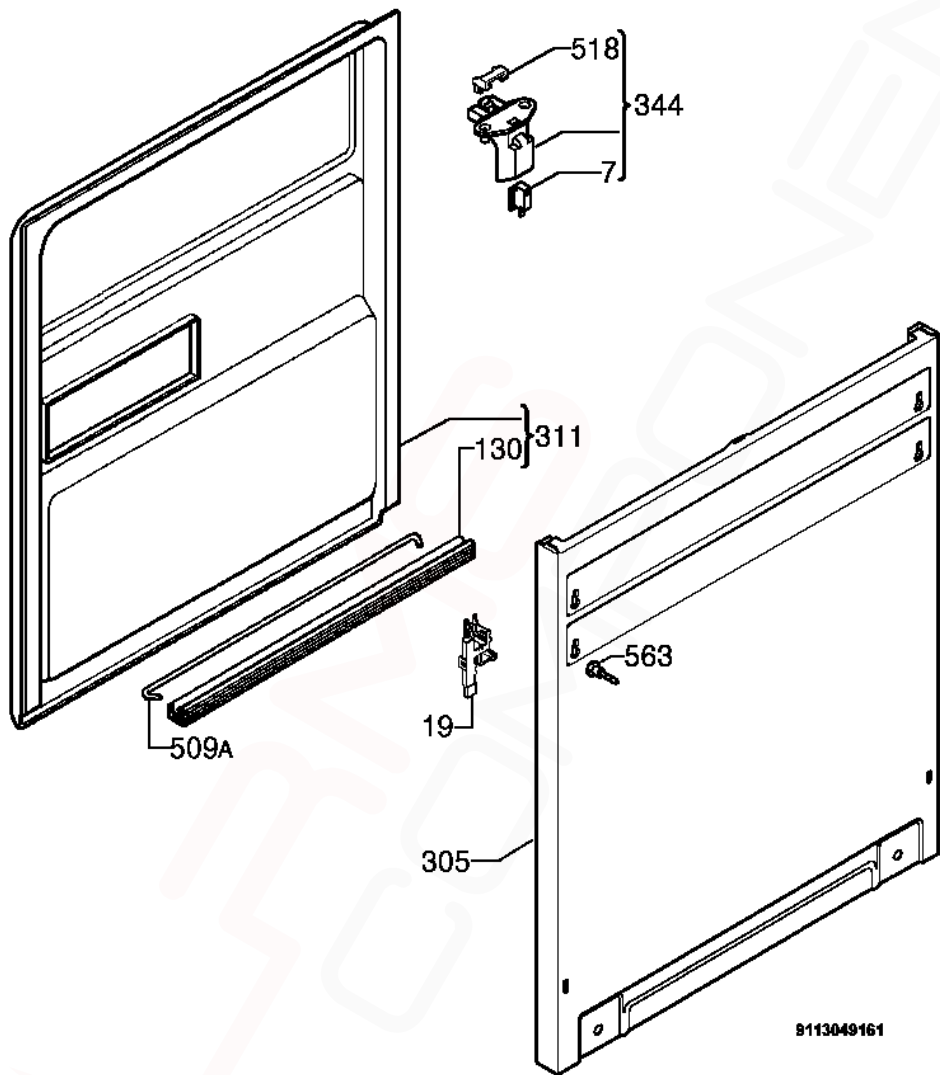

9113049161

**MODELS: ESL66010**  
**ESL66010B**

**PNC 911936254 00**  
**PNC 911936254 00**

**EX. VIEW 9113049161**  
**DOOR ASSEMBLY**

ITEM	PART N°	DESCRIPTION	Ex. View 9113049161	QTY
7	<b>50287927-00/3</b>	Microswitch Door		1
19	<b>1111414-13/0</b>	Door Indicator Lamp Light Bottom		1
130	<b>1527401-00/2</b>	Door Gasket Bottom Black x 550mm Long		1
305	<b>1524571401</b>	Door Integrated Zinc Plated		1
311	<b>50290200-00/0</b>	Inner Door Complete		1
344	<b>1526377-08/8</b>	Latch Bridging Plug Complete		1
509A	<b>1520419-14/2</b>	Tie Hinge		1
518	<b>1526414-02/2</b>	Bridge Door Lock		1
563	<b>50290016-00/0</b>	Kit Peg Door Panel		1
N.I.	<b>1170635021</b>	Template Installation Column		1
N.I.	<b>1172945303</b>	Operating Plate		1

**ESL66010B ONLY**

N.I.	<b>* DWEB001</b>	Door Ebony Kit		1
N.I.	<b>** 0050010765K</b>	Handle Door Kit		-

\* Order this Part N°. for Outer Door Panel replacement. Contains Black Outer Door Panel, Door Handle and Screws.

\*\* Order this Part N°. for Door Handle replacement only

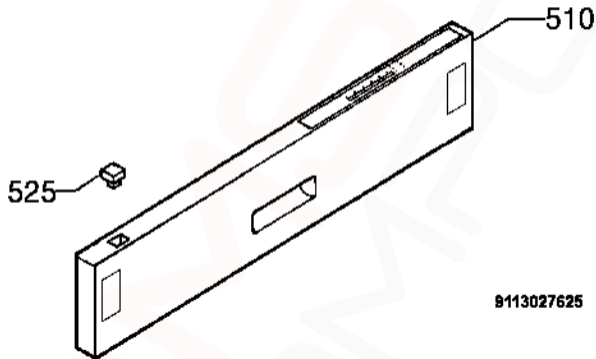

9113027625

9113027625

**MODELS: ESL66010  
ESL66010B**

**PNC 911936254  
PNC 911936254**

**EX. VIEW 9113027625  
CONTROL PANEL**

<b>ITEM</b>	<b>PARTN°</b>	<b>DESCRIPTION</b>	<b>Ex View 9113027625</b>	<b>QTY</b>
510	<b>1529489328</b>	Control Panel Silkscreened Complete		1
525	<b>1527641706</b>	ON/OFF Button Silver		1



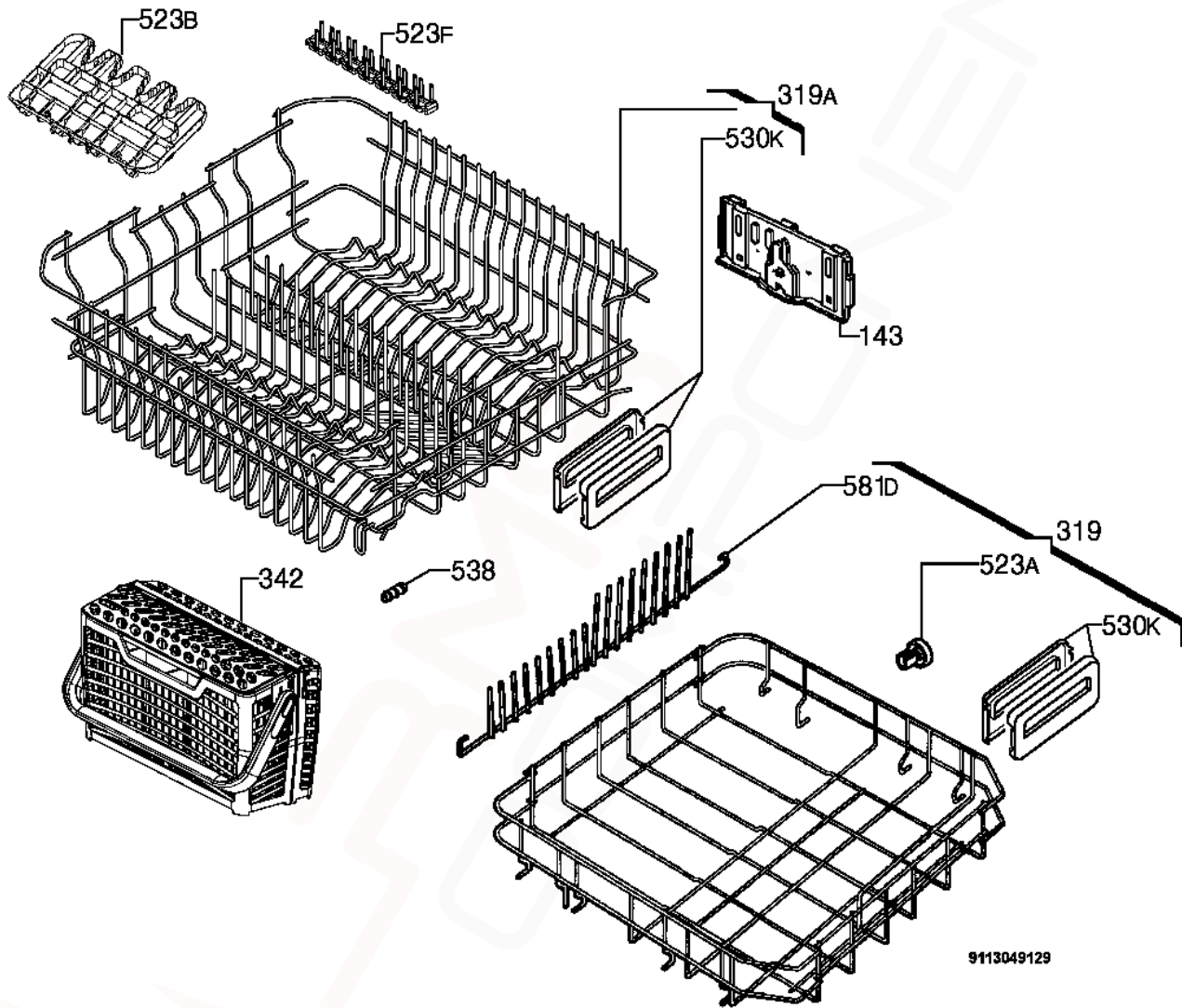

**MODELS: ESL66010  
ESL66010B**

**PNC 911936254 00  
PNC 911936254 00**

**EX. VIEW 9113049129  
BASKET ASSEMBLY**

<b>ITEM</b>	<b>PART N°</b>	<b>DESCRIPTION</b>	<b>Ex. View 9113049129</b>	<b>QTY</b>
143	<b>1527359-32/5</b>	Adjustment Right Dark Grey QUICK LIFT		1
	<b>1527359-40/8</b>	Adjustment Left Dark Grey QUICK LIFT		1
319	<b>1170595126</b>	Dishwasher Basket Bottom Dark Grey		1
319A	<b>1170539157</b>	Dishwasher Basket Upper Dark Grey		1
342	<b>1170388-00/1</b>	Cutlery Basket Complete		1
523A	<b>50286965-00/4</b>	Wheel Kit Dark Grey (8 Pieces)		1
523B	<b>1170294-01/9</b>	Support Cup Silver		4
523F	<b>1528354-10/1</b>	Support Measure Cup Silver		4
530K	<b>4055069951</b>	Kit Handle Front		2
538	<b>1170324-00/6</b>	Space Compensator Upper Basket		2
581D	<b>1527092-41/3</b>	Separator Rear Back		2
	<b>1527092-51/2</b>	Separator Rear Front		2