



ELECTROLUX HOME PRODUCTS PTY LTD
ABN 51 004 762 341

Technical Publication N° DW265

Issue: &
Date: (#/&

ELECTROLUX
ELECTRONIC DISHWASHER

**TO BE USED IN CONJUNCTION WITH
CIRCUIT and WIRING DIAGRAM PUBLICATION - DW230.**

MODEL:

ESF65060X
PNC 911915621 04

VARIANT CHANGE SUMMARY	
04	Air Guide Active Dry, Drying Pipe, Crossbar Front Upper, Hole Cover Latch, Kit Stud L/R, Latch Bridging Complete, Stiffening Door, Support Overflow Complete, PCB, Harness, Container Cup Small, Basement & Programme Buttons.

First Release Dates:	
ESF65060X/911915621 04	21/05/2010

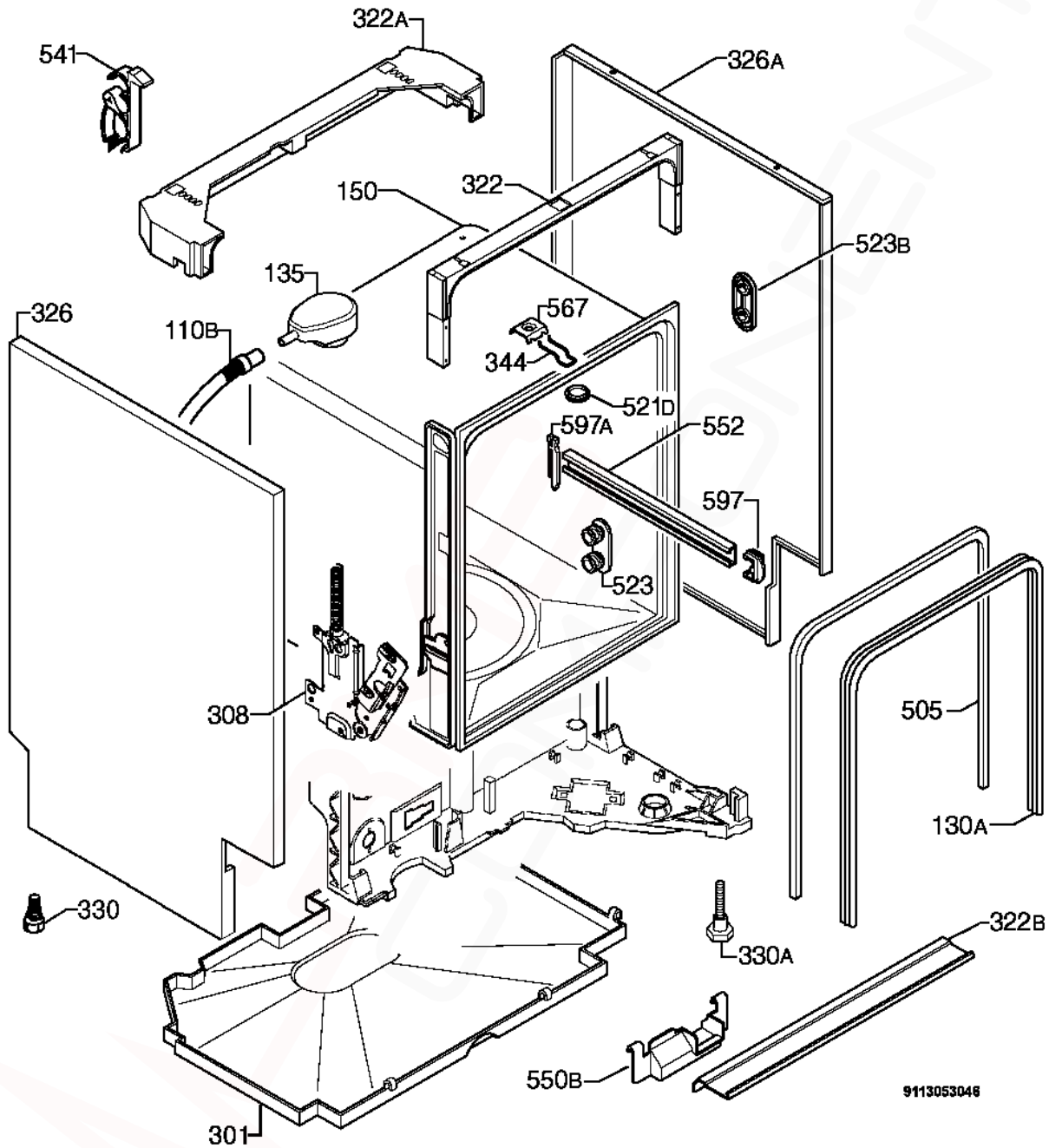

9113053046

ITEM	PART N°	DESCRIPTION	Ex. 9113053046	QTY
110B	1172814103	Drying Pipe		1
130A	1171265026	Sealing Outer x 1730mm Long		1
135	1171458209	Air Guide - Active Drying		1
150	N.P.A.	Tub		-
301	1526298-07/8	Bottom Cabinet		1
308	4055031332	Kit Door Hinge Right-Left		1
322	1525280390	Crossbar Front Upper		1
322A	1170350-01/9	Crossbar Back Upper		1
322B	1527256-10/9	Crossbar Front Bottom		1
326	1170380214	Side Panel Left Silver		1
326A	1170380313	Side Panel Right Silver		1
330	1521870-01/2	Adjustable Foot		2
330A	1527992026	Adjustable Foot Front 30mm		2
344	1522344-05/8	Latch		1
505	1526715402	Trimming Tub Black x 1710mm Long		1
521D	1526576101	Hole Cover Latch		1
523	50299970009	Wheel Support Kit Dark Grey (Pkt of 4)		1
523B	1521220-10/1	Stiffening Holder Roller		4
541	1526417-00/9	Hose Clamp		1
550B	1522345-03/0	Wiring Protection		1
552	1170542-00/3	Rail Basket Upper		2
567	1523236-03/0	Plaque (Speed Clip)		1
597	1520479-30/2	Basket Stop Front Dark Grey		2
597A	8996461234-05/7	Stopper Back Dark Grey		2
N.I.	4055046587	Fixing Clip Stud (4 Pieces)		1
N.I.	4055071387	Kit Stud Right/Left		1

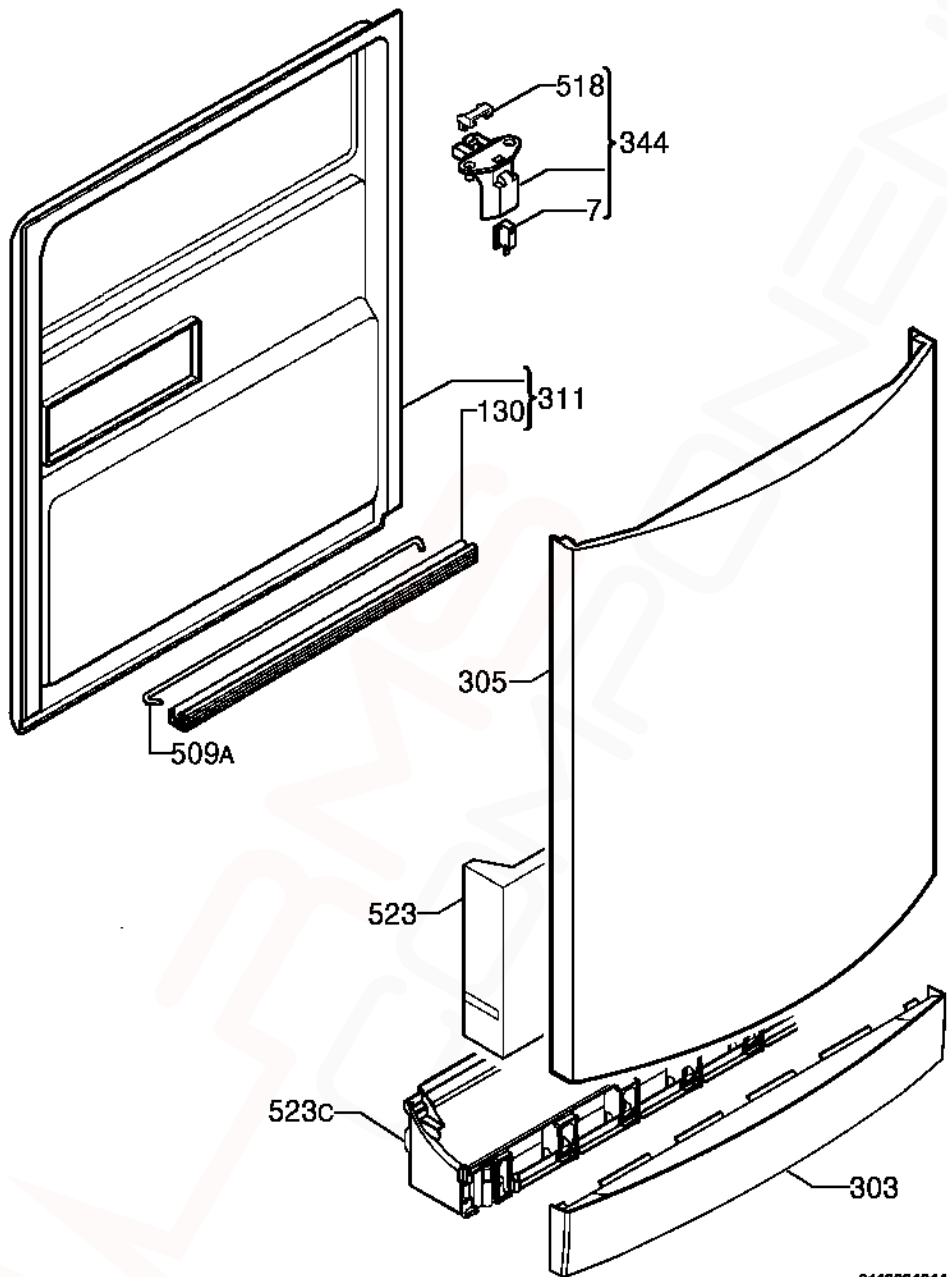

9113031014x

MODEL: ESF65060X**PNC 911915621 04****EX. VIEW 9113031014
DOOR COMPLETE
ASSEMBLY**

ITEM	PART N°	DESCRIPTION Ex. 9113031014	QTY
7	50287927-00/3	Microswitch Door	1
130	1527401-00/2	Door Gasket Bottom Black x 550mm Long	1
303	1172007211	Plinth Inox	1
305	1170377418	Door Inox	1
311	50290200-00/0	Inner Door Complete	1
344	1526377-08/8	Latch Bridging Plug Complete	1
509A	1520419-14/2	Tie Hinge	1
518	1526414-02/2	Bridge Door Lock	1
523	1172914002	Stiffening Door	1
523C	1170374027	Support Plinth	1
N.I.	50279682004	Plaque (Speed Clip)	1

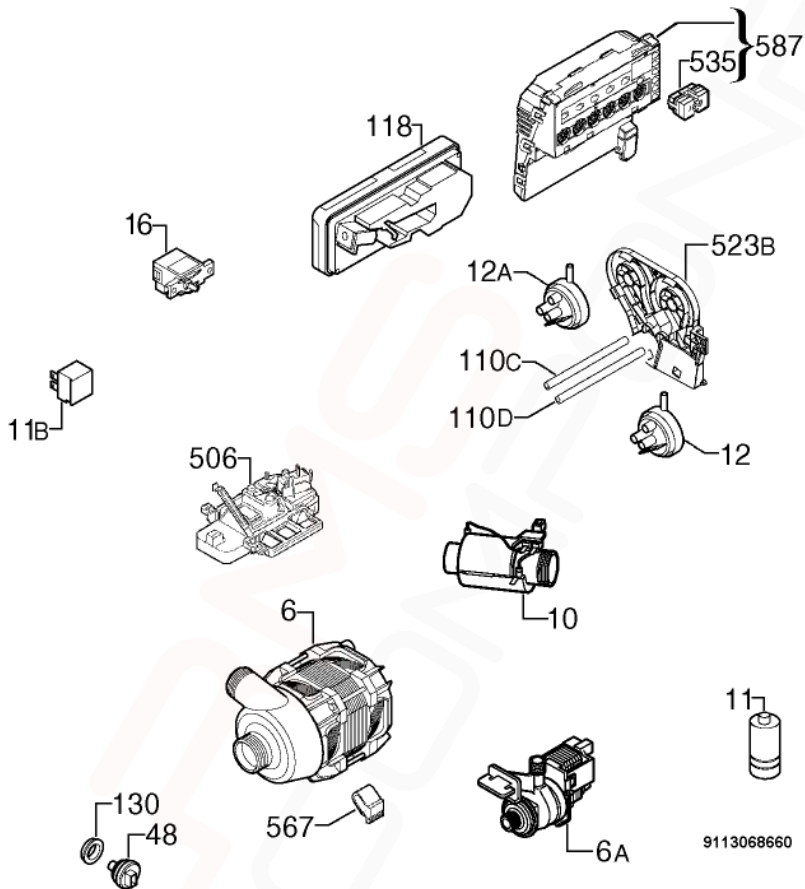

9113068660

ITEM	PART N°	DESCRIPTION	Ex. 9113068660	QTY
6	50299965009	Washing Motor Tachometric 2800 RPM		1
6A	1528261-02/5	Drain Pump 50Hz		1
10	50297618-00/6	Heating Element 230V/2000W Ø32mm		1
11	50287485-00/2	Running Capacitor Shank		1
11B	0144400042	Interference Suppressor		1
12	1528189-02/8	Pressure Switch Level 65/45		1
12A	1528189-12/7	Pressure Switch Safety 123/98		1
16	1111433-00/7	Main Switch (O/I)		1
48	1113160004	Temperature Sensor Turbidity Sensor		1
110C	1170450-40/5	Tube Pressure Switch Safety x 515mm Long		1
110D	1170450-51/2	Tube Pressure Switch Level x 525mm Long		1
118	1113330128	Kit Dispenser Detergent		1
130	0208400152	Sealing Sleeve Temperature Sensor		1
506	1172731026	Kit Support Float Complete		1
523B	1170351-00/9	Mount Pressure Switch		1
535	1529380-00/6	Display		1
567	1171934019	Motor Bracket Buffer		1
587	973911915621040	Configured Electronic EDW1500		1
N.I.	1170598-00/5	Sponge Drain Pump "L"		1
N.I.	1170862-31/0	Power Cable AUS/NZ		1
N.I.	1526491-01/2	Electric Cable Anti-overflow Gasket		1
N.I.	1527921637	Harness Complete		1

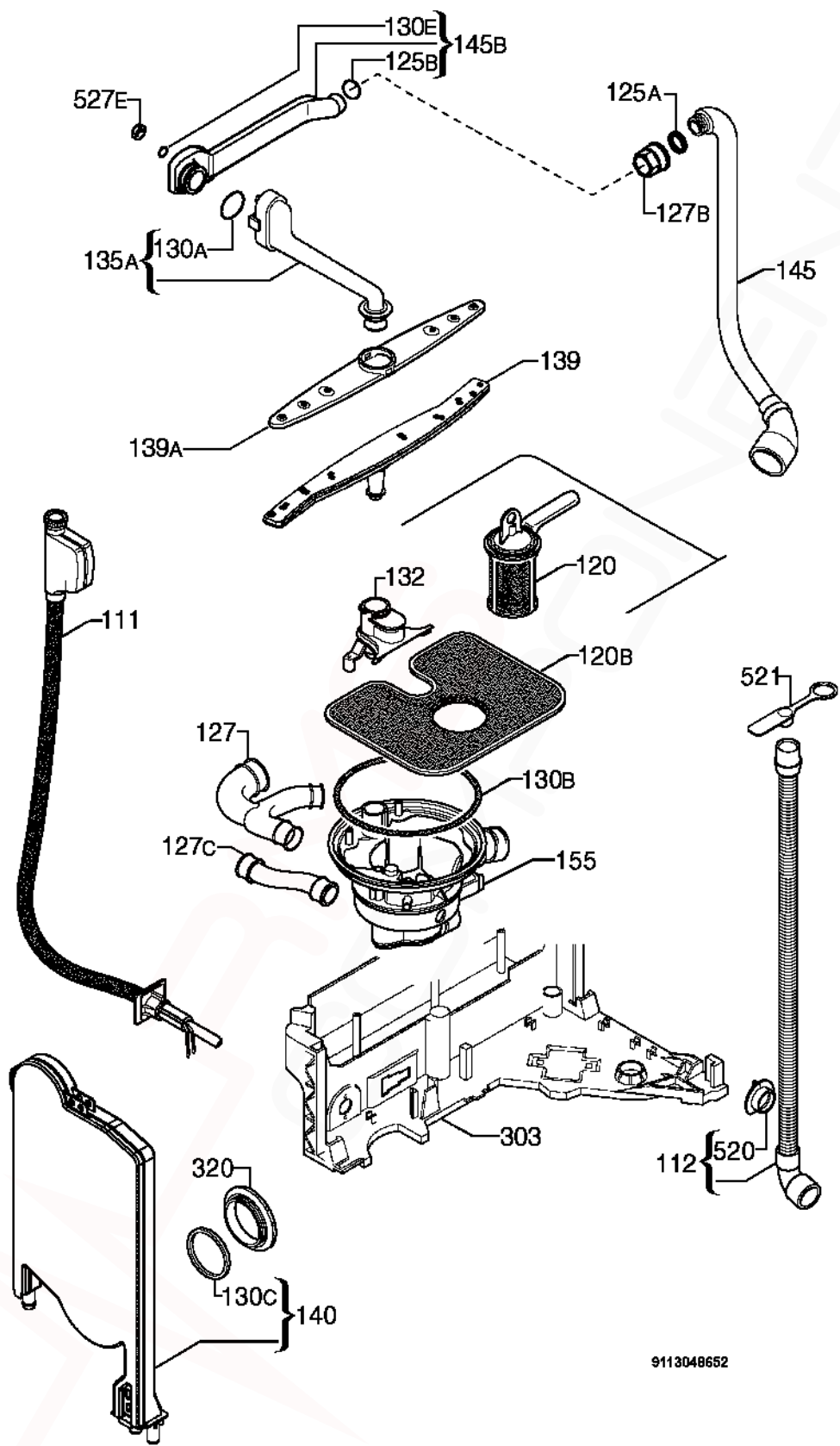

ITEM	PART N°	DESCRIPTION	Ex. 9113048652	QTY
111	50295663-00/4	Inlet Hose Water Block x 1800mm Long		1
112	1526492424	Discharge Pipe Complete x 2230mm Long		1
120	50297774-00/7	Drain Filter Complete Light Grey		1
120B	1528918-00/4	Dish Sieve Inox		1
125A	50282650-00/6	O-Ring Manifold Outer		1
125B	50227938-00/3	O-Ring Manifold Inner		1
127	1118796208	Pipe Union Y		1
127B	1523118-20/4	Pipe Union Manifold Dark Grey		1
127C	1526716-01/2	Pipe Union Decalcifier Sump		1
130A	1172041004	Rubber Gasket Channel Drainage		1
130B	0208400147	O-Ring Sump		1
130C	50659231-00/0	Round Seal Container Cup		1
130E	1522802-00/6	Sealing Strip		1
132	0012400051	Column Support Lower Spray Arm		1
135A	1170370025	Channel Drainage Dark Grey Complete (not as illustrated)		1
139	1118136702	Spray Arm Bottom Dark Grey		1
139A	1118949500	Upper Spray Arm Dark Grey		1
140	1170481020	Container Cup Small Electronic		1
145	1528059-00/7	Manifold Outer Ø32mm		1
145B	1172029017	Manifold Horizontal Dark Grey (not as illustrated)		1
155	1527957128	Sump Pipe Union Complete		1
303	1526292212	Basement		1
320	1526272-10/7	Grill Vapour Outlet Dark Grey		1
520	N.P.A.	Flange Discharge Pipe		-
521	N.P.A.	Stopper Drainage Hose		1
527E	50286080-00/2	Nut Water Distributor		1
N.I.	1529175109	Fixing Clamp Sensor		1
N.I.	4055034963	Service Kit Electric Cable Sensor		1
N.I.	1172041004	Seal Channel Drainage		1

If a Customer needs to extend their Drain Hose, order the following components:
0571400142 Hose Drain (2M length), 0182200002 Ferrule Hose Joiner (19mm)
and 2 x 0005001019 Clamp.

For extensions less than 2 metres, use ES5323K Kit Hose Flex Drain (1M)

NOTE: Total Drain Hose length must not exceed 4 metres.

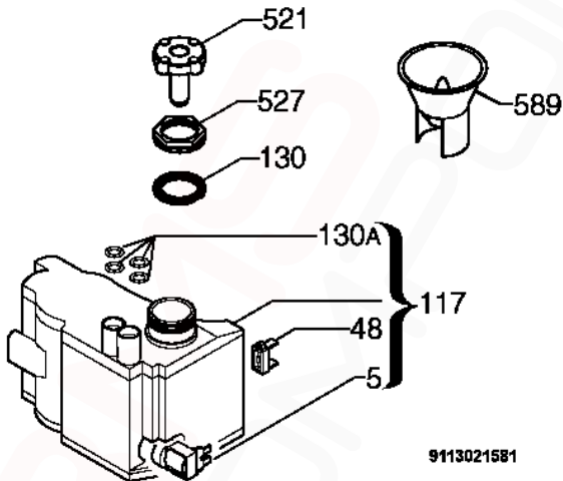

9113021581

9113021581

MODEL: ESF65060X

PNC 911915621 04

**EX. VIEW 9113021581
REGENERATION TANK
ASSEMBLY**

ITEM	PART N°	DESCRIPTION	Ex. 9113021581	QTY
5	1528765-01/7	Regeneration Electric Valve Water Softener		1
48	1528882-01/0	Salt Sensor Decalcifier		1
117	50286081-00/0	Decalcifier		1
130	1521128-10/6	Gasket Decalcifier		1
130A	1526505-00/1	Grommet Decalcifier		4
521	1526411-00/2	Stoppie Decalcifier		1
527	1526449-10/1	Ring Nut Decalcifier Dark Grey		1
589	1172107300	Filling Funnel Dishwasher Salt Transparent		1

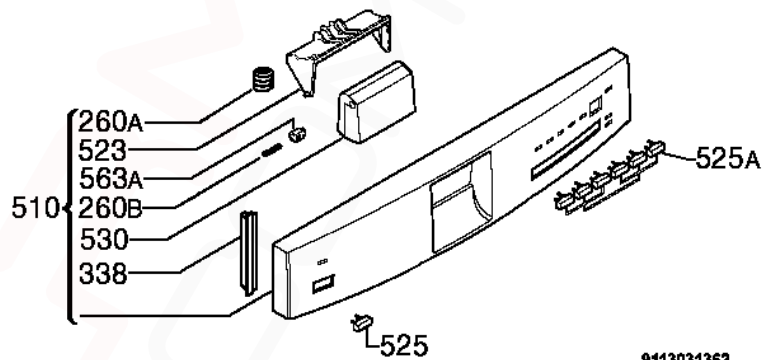
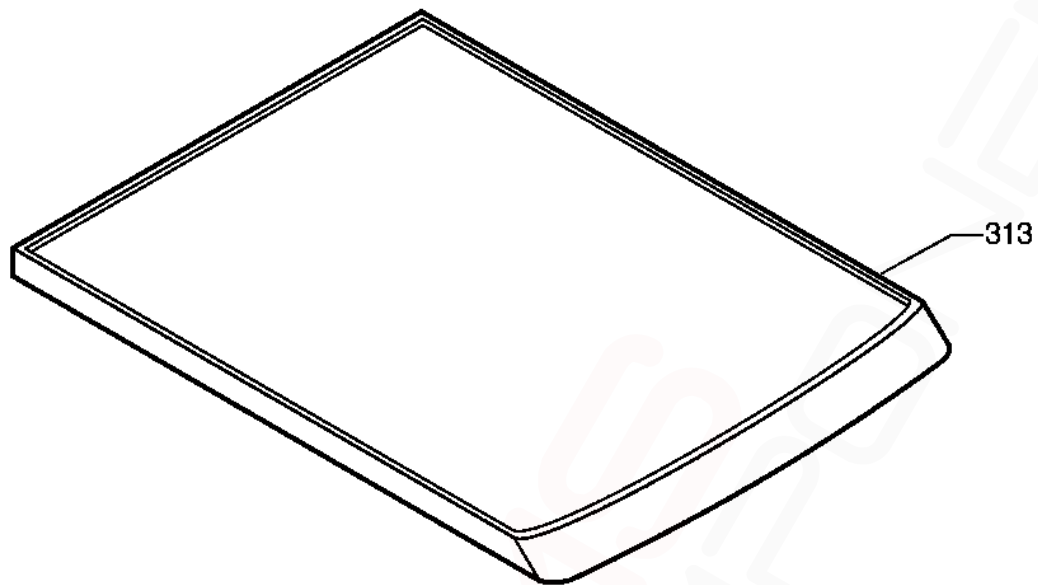

9113031362

ITEM	PART N°	DESCRIPTION	Ex. 9113031362	QTY
260A	1171020009	Spring Handle		1
260B	1527808008	Spring Side Handle		1
313	1171793316	Work Top		1
338	1525578-80/1	Side Plate Grey		2
510	1171819608	Control Panel Silkscreened Complete		1
523	1170464026	Handle Bracket		1
525	1528655317	On/Off Button - Inox		1
525A	1172835108	Button Programme - Inox		1
530	1172470203	Handle Control Panel - Inox		1
563A	1527582009	Pin Handle		1

NOTE: In cases where the Work Top has been removed for under counter installation, supply 2 x **1170209-00/9 BRACKET FIXING TOP** and 1 x **ES6060 KIT TAPE FOIL STEAM PROTECTION** (NOT supplied in original pack)

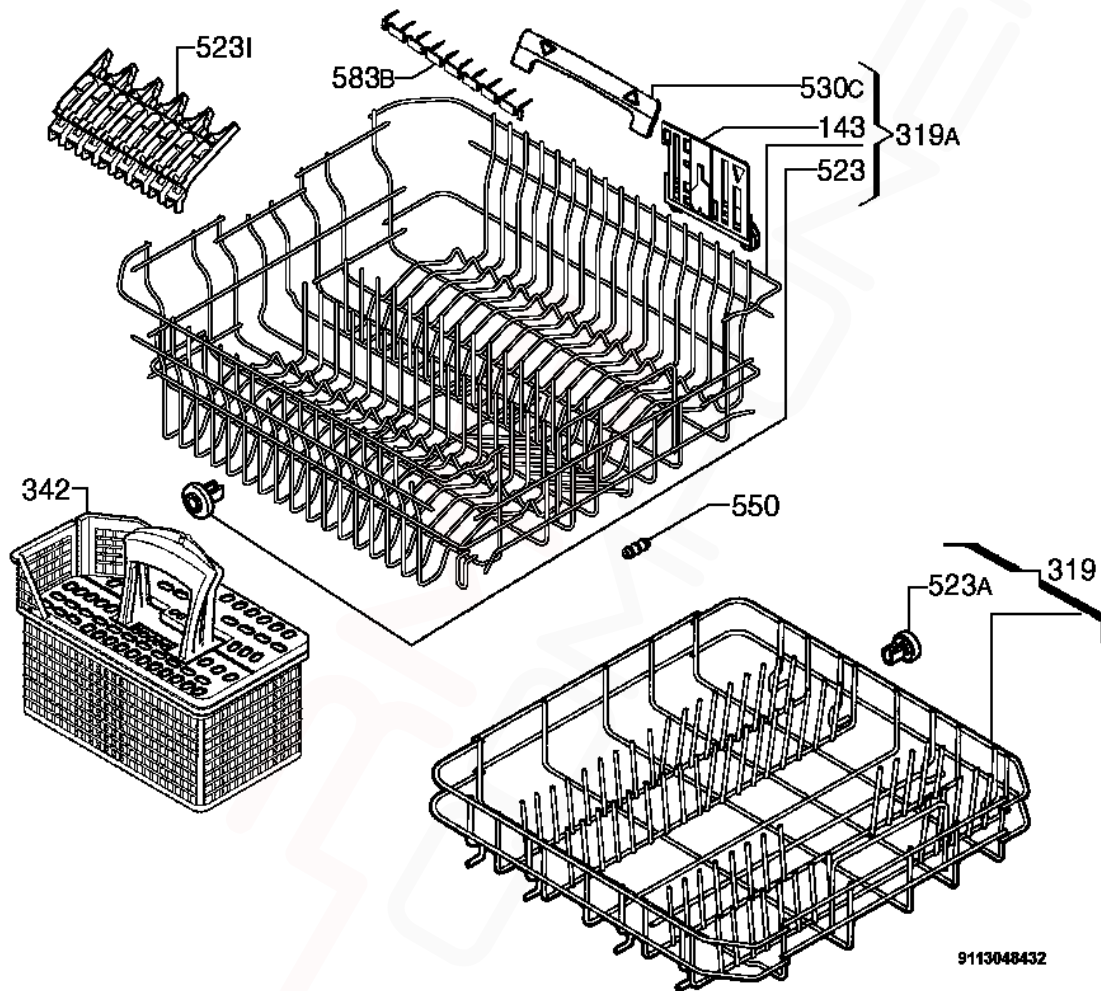

9113048432

9113048432

MODEL: ESF65060X**PNC 911915621 04****EX. VIEW 9113048432
BASKET ASSEMBLY**

ITEM	PART N°	DESCRIPTION	Ex. 9113048432	QTY
143	1172121004	Adjustment Dishwasher Basket Right		1
319	1170652-60/4	Dishwasher Basket Bottom Dark Grey		1
319A	1170456360	Dishwasher Basket Upper Dark Grey		1
342	1118401502	Cutlery Basket Complete Dark Grey		1
523	4055039723	Wheel Upper Basket Complete		2
523A	50286965-00/4	Wheel Kit Dark Grey (8 Pieces)		1
523I	1118886702	Rack Cup Dark Grey		4
530C	4071354775	Handle Side Complete		1
550	8996461804602	Rubber Buffer Dishwasher Basket Upper		2
583B	1118902707	Spacer Dark Grey		4