



**ELECTROLUX HOME PRODUCTS PTY LTD**  
ABN 51 004 762 341

Technical Publication N° RH1019

Issue: 1  
Date: 10/16

# ***ELECTROLUX***

## ***DOMESTIC HOUSEHOLD RANGEHOOD***

### ***100cm ISLAND CANOPY***

<b>CONTENTS</b>	<b>PAGE N°</b>
<b>ISLAND CANOPY ASSEMBLY</b>	<b>2</b>
<b>MOTOR &amp; ELECTRICAL COMPONENTS</b>	<b>3</b>
<b>COVER FLUE and DUCT COMPONENTS</b>	<b>4</b>
<b>WIRING DIAGRAM</b>	<b>5</b>

**NOTE: In Parts Listings**

<b>N.I.</b>	<b>=</b>	<b>Not Illustrated</b>
<b>N.P.A.</b>	<b>=</b>	<b>No Part Available</b>
<b>N.P.N.</b>	<b>=</b>	<b>Not Used on this Model</b>

***MODEL:***

***ERCI931SA***

***PNC:***

***942001292 00***

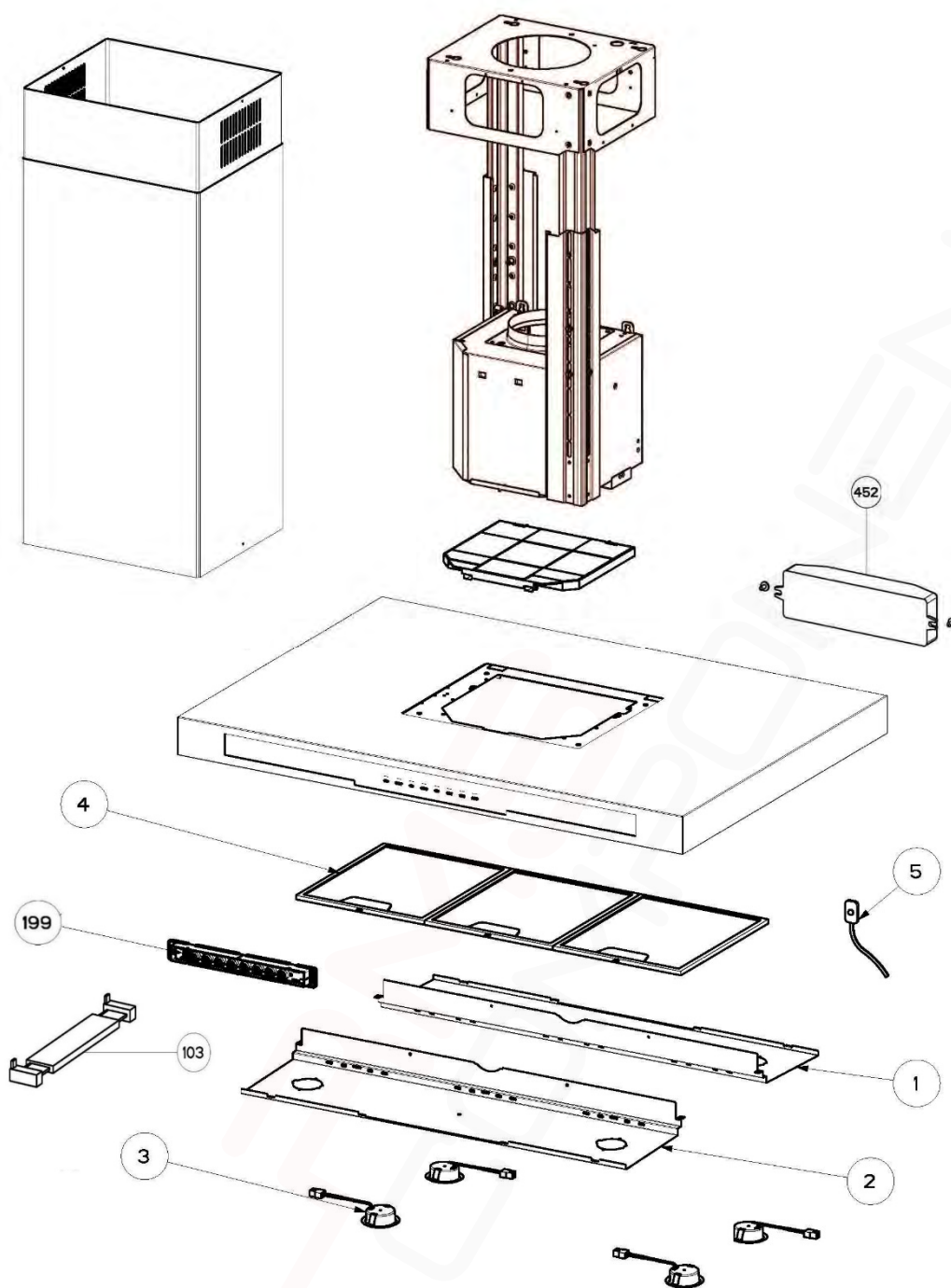
ISLAND CANOPY  
ASSEMBLY

ITEM	PART N°	DESCRIPTION	Ex. 07A_720_01	QTY
1	1330204229	PANEL SUPPORT LED REAR		1
2	1330395128	PANEL SUPPORT LED FRONT-SENSOR		1
3	1330299379	LAMP LED S1000 4000K		4
4	1330067471	FILTER ALUM MESH 253x300		3
5	1330308667	SENSOR RECEIVER CARD + BOX		1
103	1330428515	HARNESS FLAT 9WAY CON x 1000mm		1
199	1330383373	SWITCH ELECTRONIC ASSEMBLY		1
452	1330299377	TRANSFORMER DC8W 12V R 110-240		1

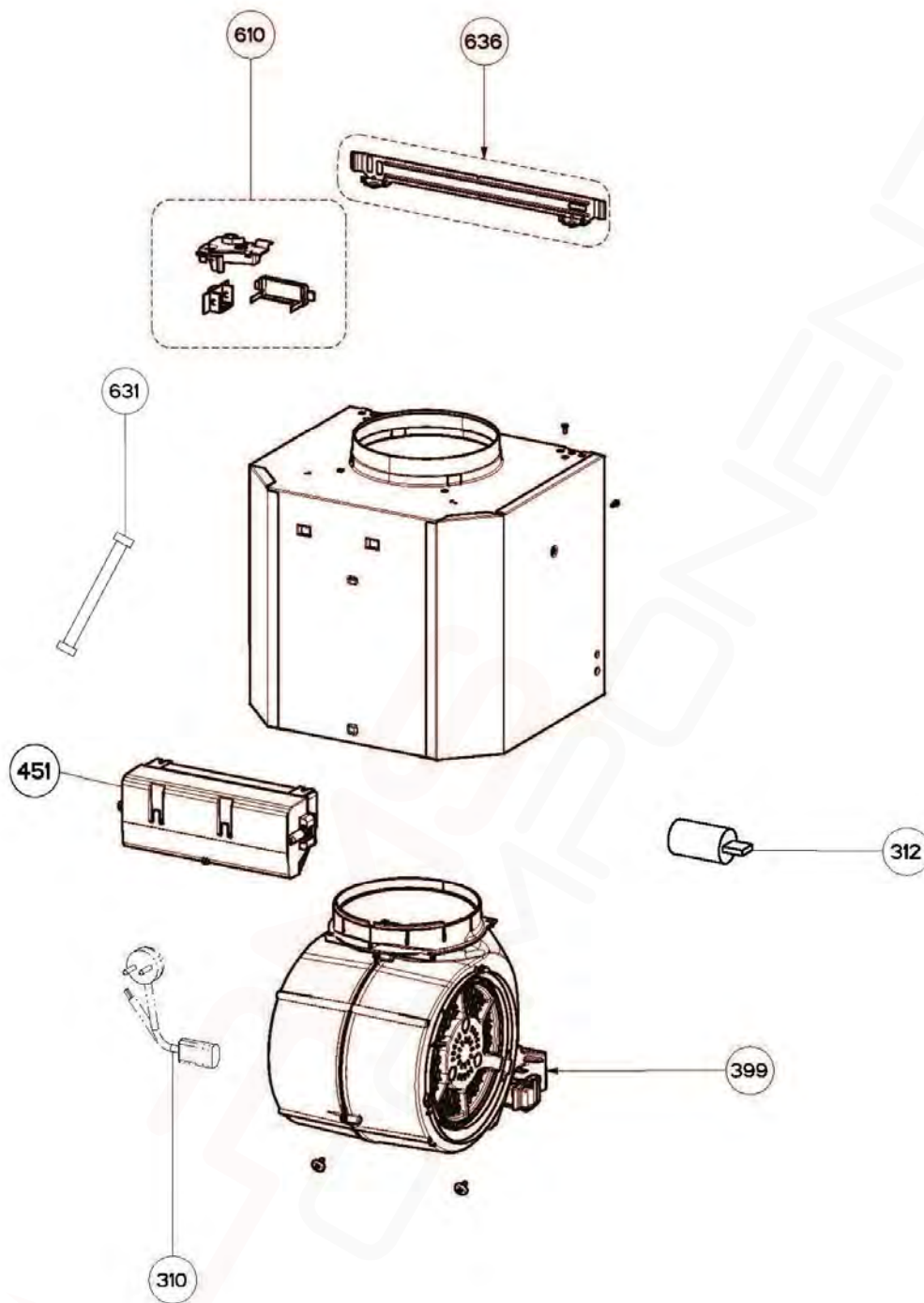

ITEM	PART N°	DESCRIPTION	Ex. D15_701_02	QTY
310	1330056373	SERVICE CORD 3x0.75x1500 AU		1
312	1330071067	CAPACITOR 6.3µf 450V		1
399	1330047748	MOTOR BLOWER COMP ASSY 220 ENERGY		1
451	1330395089	PCB MAIN CARD+BOX H2H COMPLETE		1
610	1330198246	KIT ACCESSORIES EASY CUBE		1
631	1330191396	HARNESS FLAT 10WAY MALE 800mm		1
636	N.P.A.	NOT REQUIRED FOR THIS MODEL		-

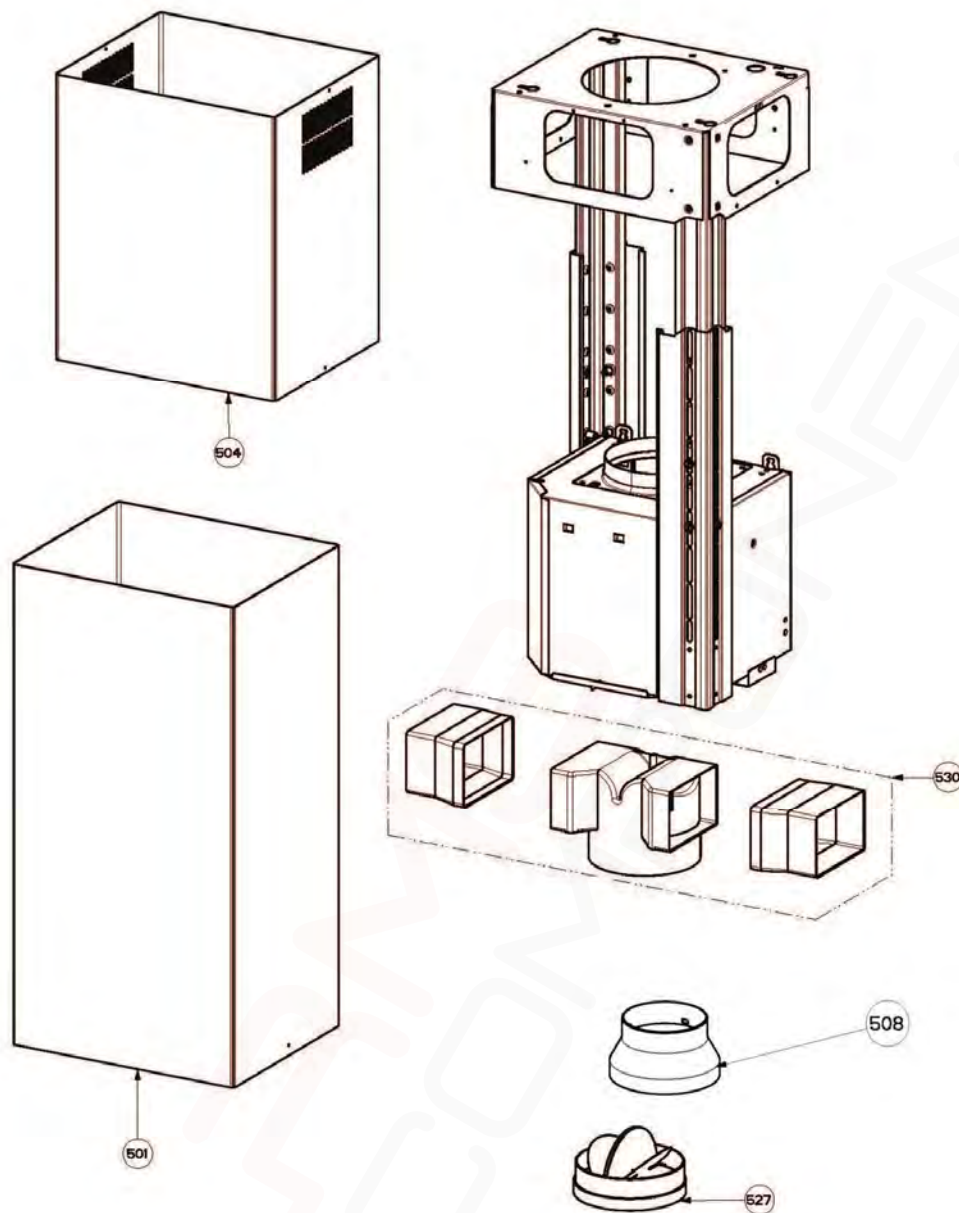

ITEM	PART N°	DESCRIPTION	Ex. SB9_719_03	QTY
501	1330386825	COVER EXHAUST LOWER WITH LOGO		1
504	1330017106	COVER EXHAUST UPPER WITH VENTS		1
508	E607210	ADAPTOR Ø150MM - Ø120MM REDUCER (optional accessory)		1
527	1330056646	FLANGE JOINER W/DAMPER Ø150		1
530	1330059736	KIT RECIRCULATING PIECE		1
N.I.	AR150F	FLUE PIPE Ø150mm x 1200mm		-
N.I.	AR150RC	COWL ROOF Ø150mm FLUE		-
N.I.	AR150FD	FLUE PIPE FLEXI Ø150mm x 1000mm		-