

Electrolux

ELECTROLUX HOME PRODUCTS PTY LTD
ABN 51 004 762 341

Technical Publication N° DW410

Issue: '
Date: \$+/1*

DISHLEX
HOUSEHOLD DISHWASHER
12 PLACE SETTING

MODEL:

DSF6305X
PNC 911516171 00

VARIANT CHANGE SUMMARY	
00	INTRODUCTION

Release Date:	
DSF6305X / 911516171 00	Oct 2014

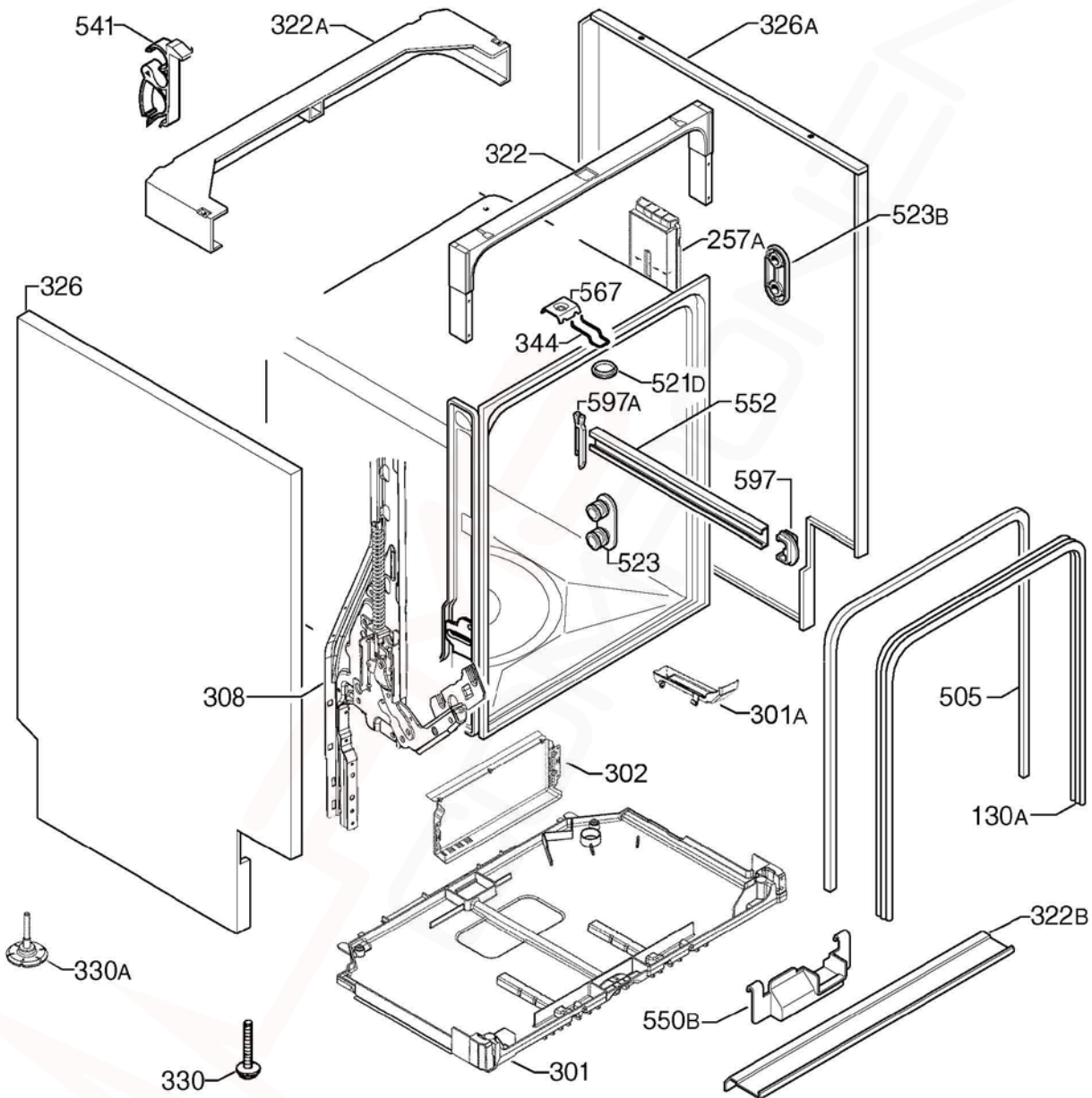

ITEM	PART N°.	DESCRIPTION EX. P09113178362	QTY
130A	1171265026	Gasket Door Outer Ø1730	1
257A	140000115018	Counterweight Side Dishwasher	1
301	140000527014	Tray Bottom Spillage	1
301A	4055250858	Kit Overflow Hose	1
302	140000750012	Cover Electronic PCB - Metal	1
308	4055161352	Kit Hinge Left-Right	1
322	1560799114	Brace Front Upper Zinc-Plated	1
322A	1170350-01/9	Brace Rear Upper	1
322B	140000212013	Brace Front Lower	1
326	1170380610	Panel Side Left - Silver	1
326A	1170380719	Panel Side Right - Silver	1
330	1520664-10/1	Foot Adjustable Ø36	2
330A	8075188014	Foot Adjustable Ø48mm	2
344	1522344-05/8	Latch Door Lock	1
505	1526715410	Trim Tub Black	1
521D	1526576101	Cover Latch Hole	1
523	50299970009	Support Roller Kit Dark Grey (4 Pack)	1
523B	1118814-00/1	Bracket Stiffening	4
541	<i>N.P.A.</i>	Hose Clamp	-
550B	1522345071	Cover Wiring Protection	1
552	140003656026	Rail Basket Upper Complete	2
567	1523236-03/0	Nut Speed Clip	1
597	1520479419	Stop Basket Upper Front D/Grey	2
597A	6461234061	Stop Basket Upper Rear D/Grey	2

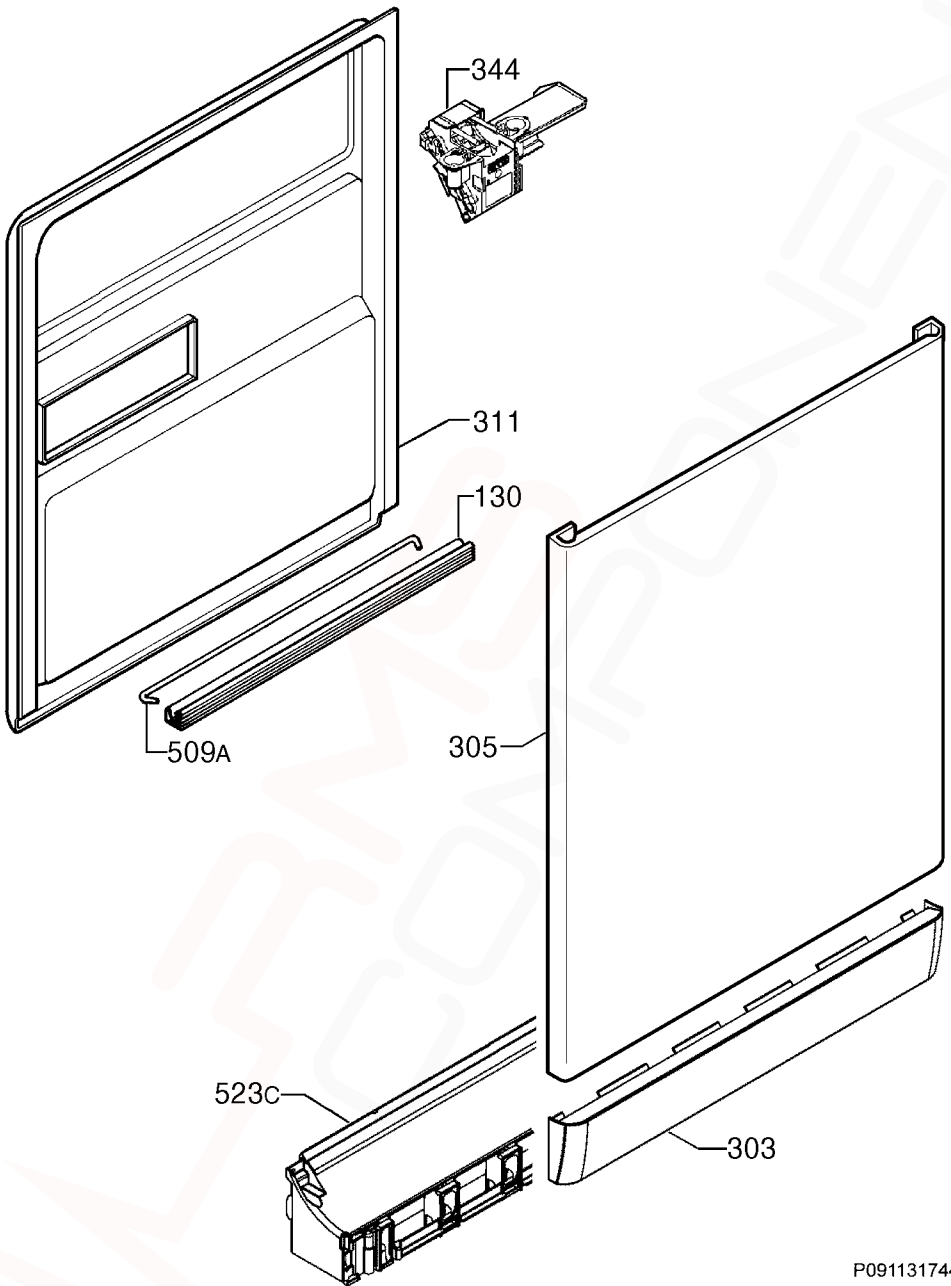

P09113184684

MODELS: DSF6305X

PNC 911516171 00

**EX. VIEW P09113174465
DOOR ASSEMBLY**

ITEM	PART N°.	DESCRIPTION	EX. P09113174465	QTY
130	1527401-00/2	Gasket Door Lower Blk x 550mm		1
303	8070407013	Plinth Inox		1
305	1561221456	Panel Door Outer - Inox		1
311	140025959028	Panel Door Inner		1
344	1113150120	Latch Door Lock		1
509A	1520419-14/2	Tie Hinge		1
523C	1170156-03/6	Holder Plinth - Dark Grey		1

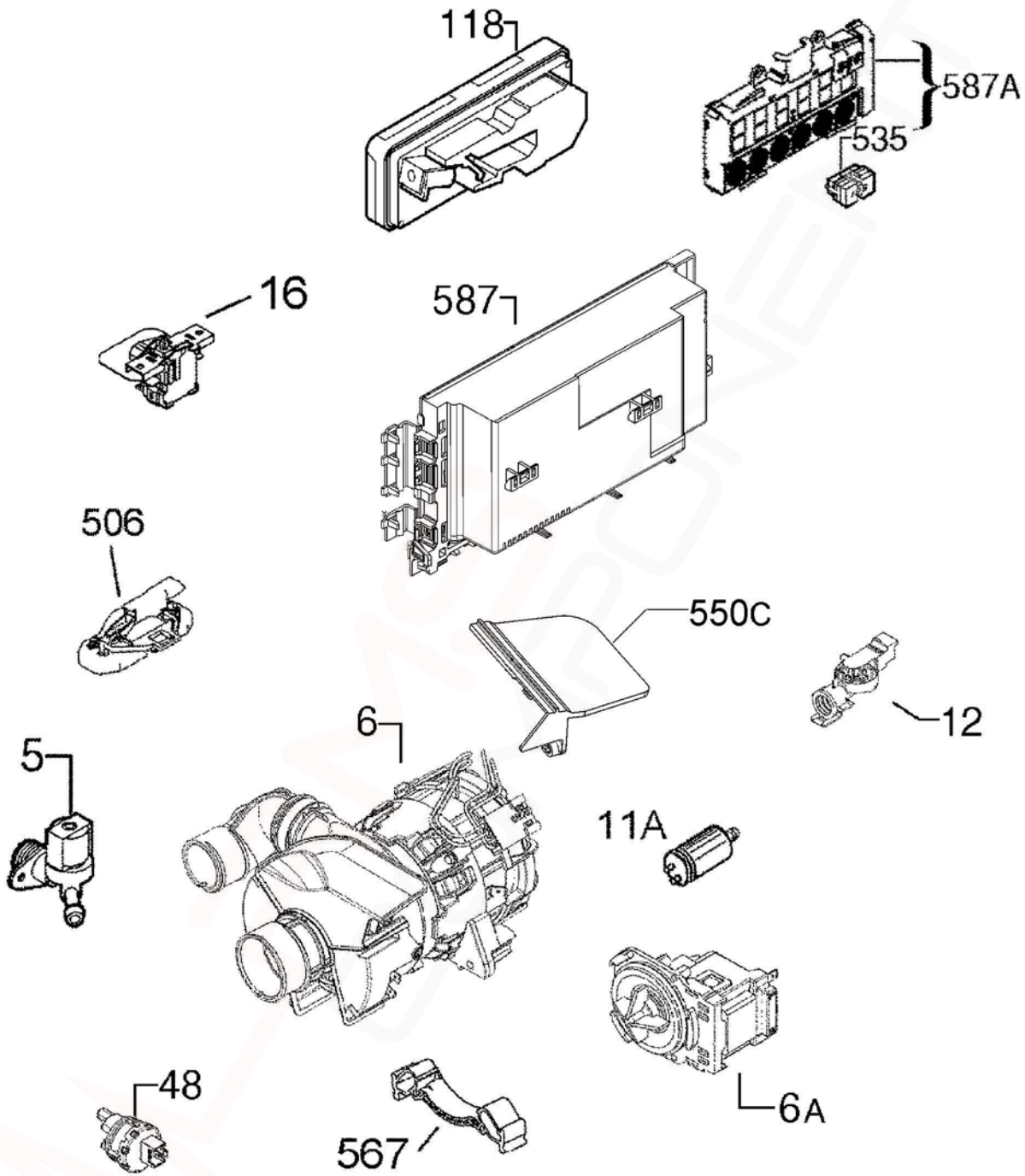

ITEM	PART N°.	DESCRIPTION	EX. P09113183466	QTY
5	140001158017	Valve Fill 2 5Lt/min		1
6	140002106056	Pump Circulation Heater Comp 1800W		1
6A	140000443030	Pump Drain 50Hz		1
11A	1115927012	Capacitor Motor 3µf		1
12	ES6176	Kit Switch Pressure		1
16	1113337024	Switch Main Auto OFF		1
48	140000401012	Sensor Temperature Turbidity		1
118	1113330128	Dispenser Detergent C/R		1
506	140000565048	Switch Float Assembly		1
535	1119387007	Display LED 7mm		1
567	1171934019	Bracket Motor Buffer		2
587	973911516170009	PCB Configured Electronic		1
587A	1113367617	PCB User Interface Amber EDW1500		1
N.I.	140001945033	Cord Service AU 2 15m		1
N.I.	8074849012	Harness PCB Heater		1
N.I.	140008919023	Harness PCB Door		1
N.I.	8091583040	Harness PCB Pump		1

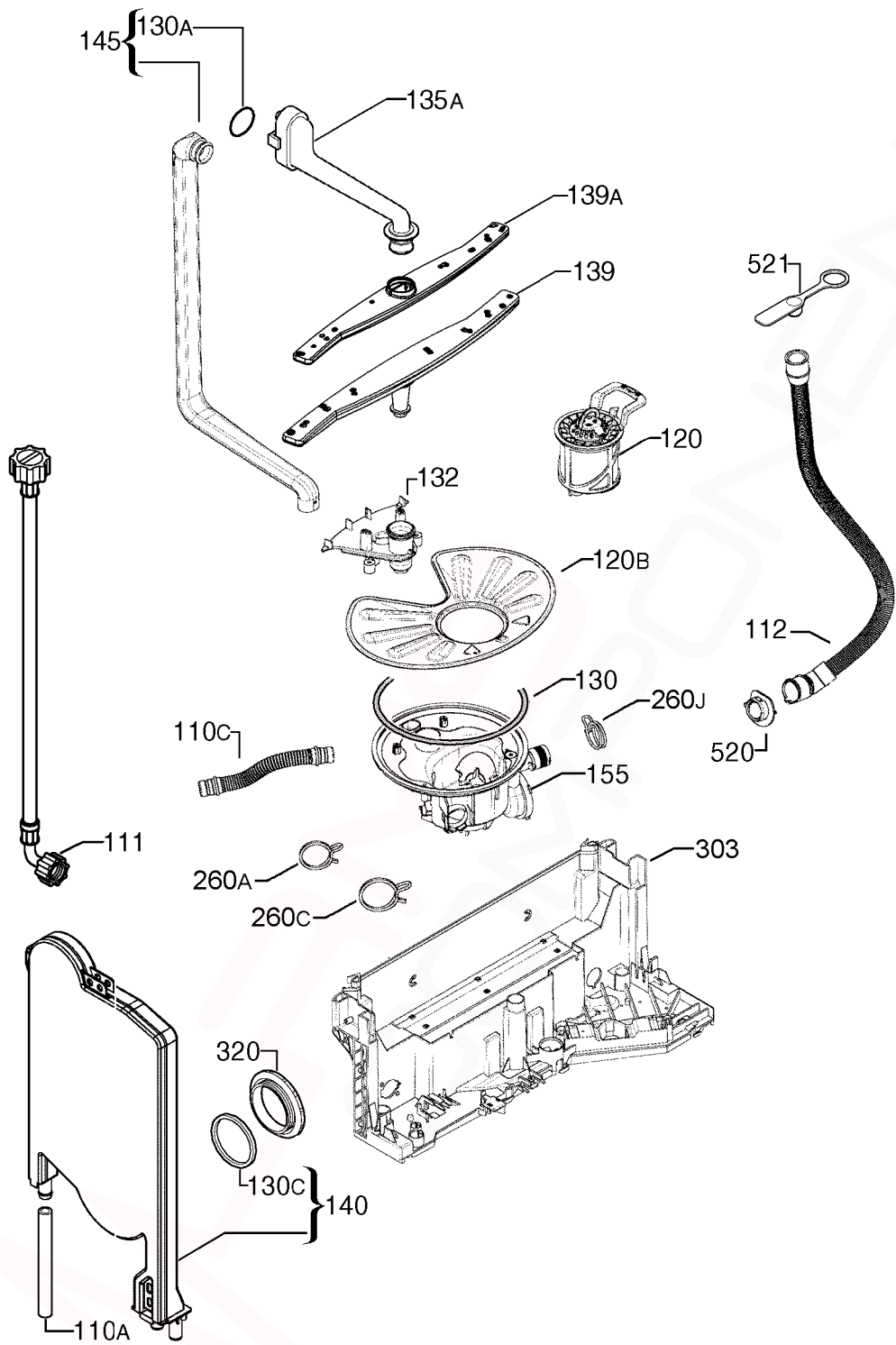

ITEM	PART N°.	DESCRIPTION	EX. P09113176038	QTY
110A	1526815-10/3	Tube Air Chamber		1
110C	14000059034	Hose Sump Water Softener x 370mm		1
111	140000234030	Hose Feeder x 1500mm		1
112	140010997017	Hose Drain x 2230mm		1
120	8075472178	Filter Drain Assembly		1
120B	1119209045	Filter Flat		1
130	1119186003	O-Ring Sump		1
130A	1523119-01/2	Seal Channel Drainage		1
130C	N.P.A.	Seal Round Container Cup		-
132	1119158135	Support Spray Arm Lower		1
135A	1561425370	Tube Feed Upper Spray Arm		1
139	140000584072	Spray Arm Lower Light Grey		1
139A	1118949526	Spray Arm Upper Light Grey x 450mm		1
140	1170481764	Container Cup Small		1
145	140000740021	Tube Manifold Inner Dark/Grey		1
155	140000494017	Sump Assembly		1
260A	8078689026	Clamp Circ Pump Flow Regulator Ø36mm		1
260C	8078689034	Clamp Circulation Pump Sump Ø45mm		1
260J	8078689018	Clamp Drain Hose Ø30mm		1
303	140000531032	Basement		1
320	1526272214	Vent Vapour Outlet		1
520	N.P.A.	Flange Discharge Hose Ø20mm		-
521	N.P.A.	Stopper Drainage Hose		-
N.I.	140000536015	Valve Non-Return Flap Sump Ø23.2mm		1

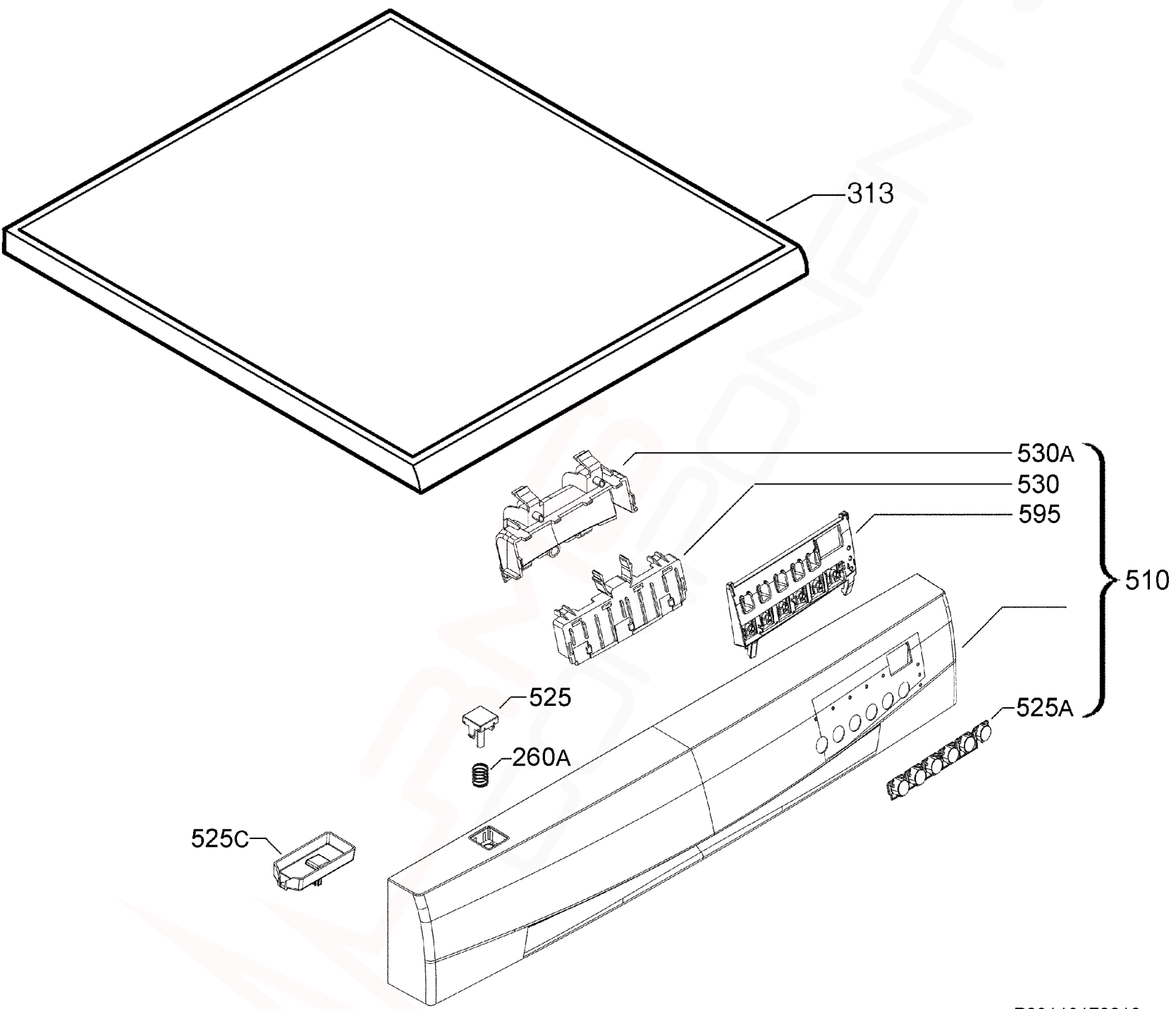

P09113184687

MODELS:**DSF6305X****PNC 911516171 00****EX. VIEW P09113176216
WORKTOP and CONTROL
PANEL ASSEMBLY**

ITEM	PART Nº.	DESCRIPTION	EX. P09113176272	QTY
260A	1173192004	Spring On/Off Button		1
313	1561348218	Work Top Inox		1
510	8086202036	Control Panel Inox DSF6205X		1
525	1173190206	Push Button On/Off Inox		1
525A	140002473027	Push Button Set 6 Button Inox		1
525C	1173189000	Push Button On/Off Protection		1
530	140002463069	Handle Grey		1
530A	140002464067	Handle Cover Grey		1
595	140002474017	Support Button Push		1
N.I.	5190530112	Screw Switch Housing 3.5x13 TTL		-

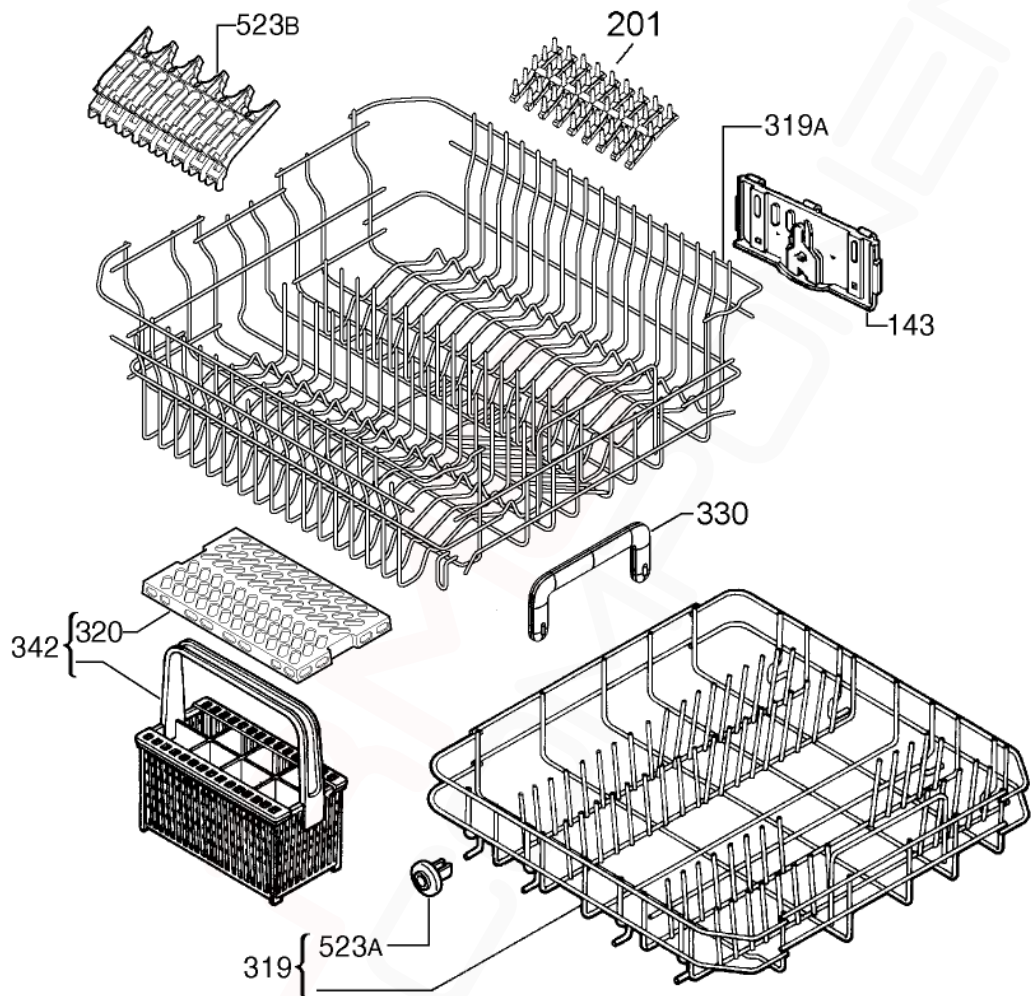

P09113176490

ITEM	PART Nº.	DESCRIPTION	EX. P09113176490	QTY
143	1527359945	Plate Adjustment Right Hand		1
	1527359-40/8	Plate Adjustment Left Hand		1
201	ACC088	Support Spikes Rubber Grey (2 per Box)		1
319	1561446285	Basket Dishwasher Bottom Assembly		1
319A	1561219005	Basket Dishwasher Upper Light Grey		1
320	N.P.A.	(Included with Item 342)		-
330	4055297552	Handle Basket Complete		1
342	ACC107	Basket Cutlery Universal		1
523A	50286965-00/4	Wheel Kit Basket Lower (8 Pieces)		1
523B	140001199029	Support Cup Grey		2
N.I.	8996461804602	Buffer Rubber Dishwasher Upper		4
N.I.	1561218007	Hook Dispenser Upper Basket		1

**DISHWASHER
ACCESSORY COMPONENTS**

EX. VIEW DRAWING 8155-8159



ITEM	PART N°	DESCRIPTION	Ex.
1	ACC017	Scalex Plus Descaler Sachet 75gm	
2	ACC100	Detergent Dishwasher 1kg	
3	ACC102	Rinse Aid Additive 500mls	
4	ACC103	Descaler Powder 350g (Dangerous Goods rules apply, min order Qty of 12)	
5	ACC002	Dishwasher Salt 1kg Pack	

LEGEND for Wiring Diagram A00185904a & A00185904b

Item	Description
BASE BOARD	Main electronic board
BOF/BH	Indication of operation
CAPACITOR	Capacitor
DISPENSER	Detergent dispenser
DOOR LOCK	Door lock
DRAIN PUMP	Drain pump
FLOW CONTROL	Flow meter
HEATER	Heating element
INLET VALVE	Inlet valve
INPUT BOARD	User interface (display)
LEAKAGE SWITCH	Anti-flooding device
MAIN SWITCH	Main switch
NTC/TURB. SENSOR	Turbidity sensor
POWER CORD	Power supply
PREASSURE SENSOR	Pressure Sensor
REG. VALVE	Regeneration valve
RINSE AID	Resin conditioning water switch
SALT AID	Salt
WASH PUMP	Washing pump
GN/YE	Green/yellow
RD	Red
BU	Blue
BR	Brown
BK	Black