

DISHLEX

***DOMESTIC HOUSEHOLD
DISHWASHERS***

CONTENTS	PAGE N°
CABINET and BASE ASSEMBLY	2 & 3
DOOR ASSEMBLY	4 & 5
ELECTRICAL COMPONENTS	6 & 7
PUMP, SUMP and HYDRAULIC SYSTEM	8 & 9
CONTROL PANEL and WORK TOP ASSEMBLY	10 & 11
BASKET ASSEMBLY	12 & 13
AFTER MARKET ACCESSORIES	14
WIRING DIAGRAM, LEGEND and CIRCUIT DIAGRAM	15 - 17

NOTE: In Parts Listings

N.I.	=	Not Illustrated
N.P.A.	=	No Part Available
N.P.N.	=	Not Used on this Model

MODEL:

DSF6305W

PNC:

911516170 03

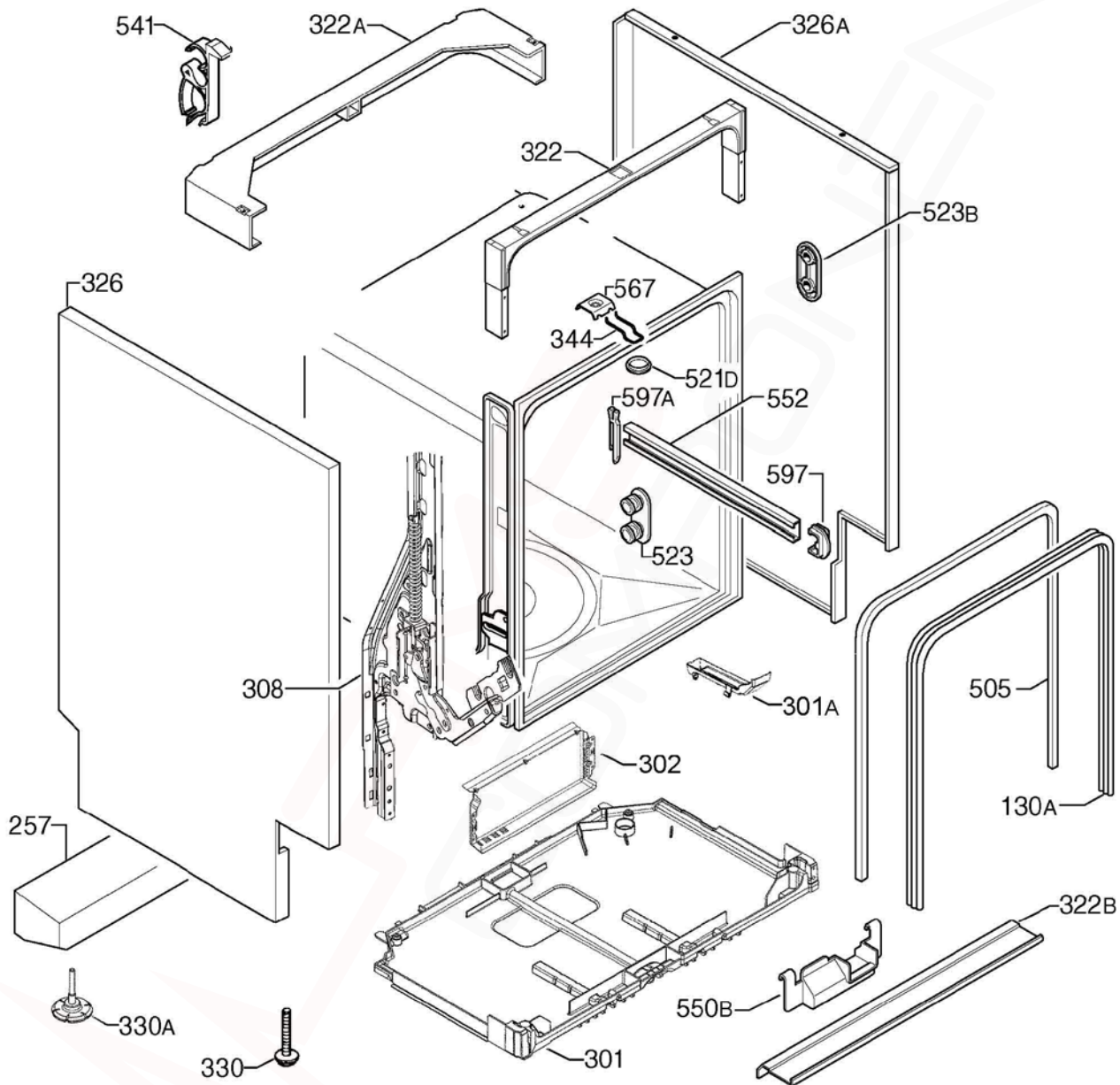

ITEM	PART N°.	DESCRIPTION EX. P091132010015	QTY
130A	1171265026	Gasket Door Ø1730	1
257A	N.P.A.	Counterweight Side Dishwasher	-
301	140000527014	Tray Bottom Spillage	1
301A	4055250858	Kit Overflow Hose	1
302	140000750012	Cover Electronic PCB - Metal	1
308	4055325056	Kit Hinge Left-Right	1
322	1560799114	Brace Front Upper Zinc-Plated	1
322A	1170350043	Brace Crossbar Upper Rear	1
322B	140000212039	Brace Crossbar Front Lower	1
326	1170153421	Panel Side Left - White	1
326A	1170153520	Panel Side Right - White	1
330	1520664-10/1	Foot Adjustable Ø36mm	2
330A	8075188014	Foot Adjustable Ø48mm	2
344	1522344-05/8	Latch Door Lock	1
505	1526715410	Trim Tub Black	1
521D	1526576101	Cover Latch Hole	1
523	50299970009	Support Roller Kit Dark Grey (4 Pk)	1
523B	1118814-00/1	Bracket Stiffening	4
541	N.P.A.	Hose Clamp	-
550B	1522345071	Cover Wiring Protection	1
552	140003656026	Rail Basket Upper	2
567	1523236-03/0	Nut Speed Clip (Plaque)	1
597	1520479419	Stop Basket Front Dark Grey	2
597A	6461234061	Stop Basket Back Dark Grey	2

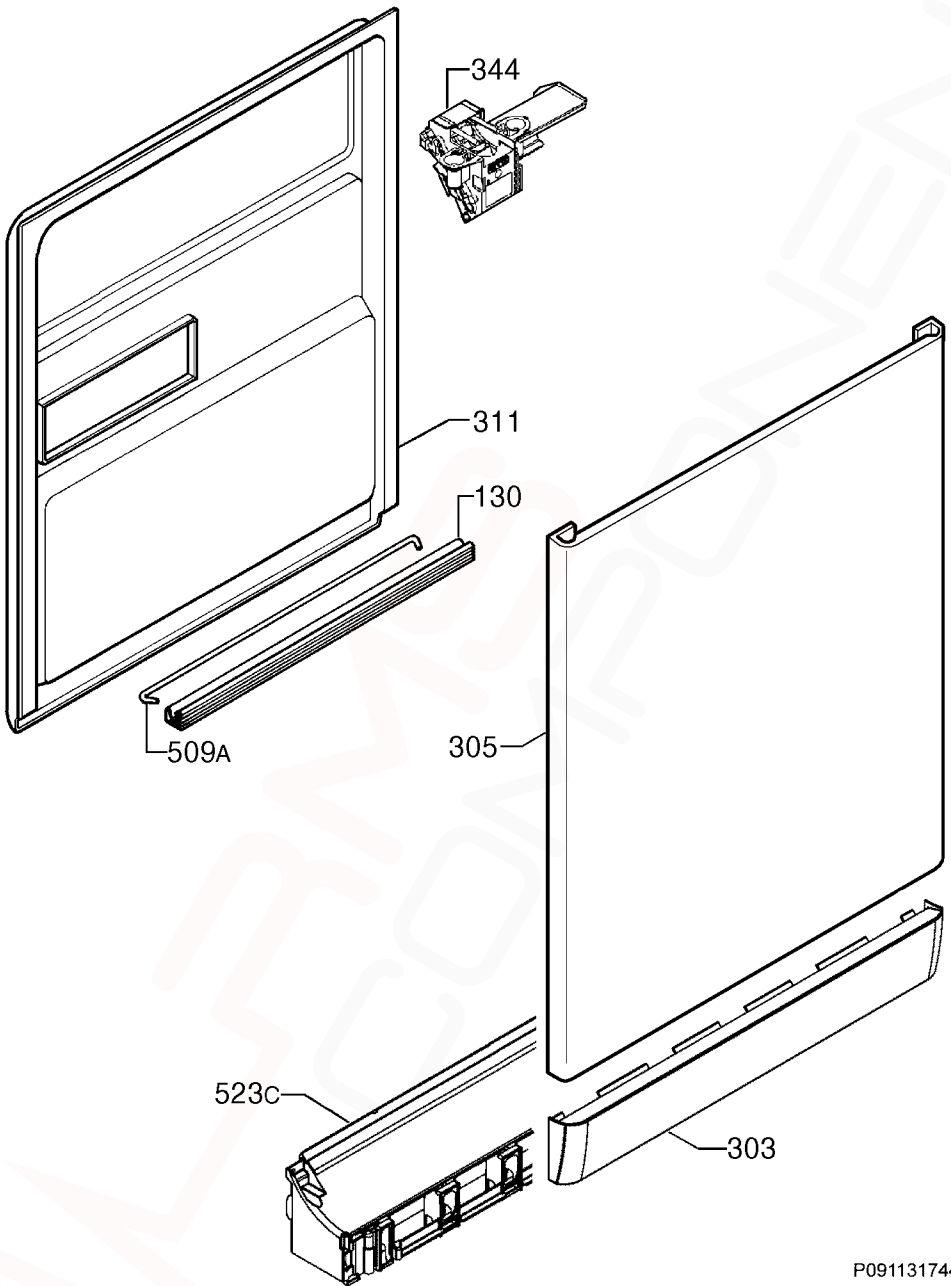

P09113200177

MODEL: DSF6305W

PNC 911516170 03

**EX. VIEW P09113174465
DOOR ASSEMBLY**

ITEM	PART N°.	DESCRIPTION	EX. P09113174465	QTY
130	1527401-00/2	Gasket Door Lower Black x550mm		1
303	8070407039	Plinth White		1
305	1561221464	Panel Door Outer - White		1
311	140025959028	Panel Door Inner		1
344	1113150120	Latch Door Complete		1
509A	1520419-14/2	Tie Hinge		1
523C	1170156-03/6	Holder Plinth - Dark Grey		1

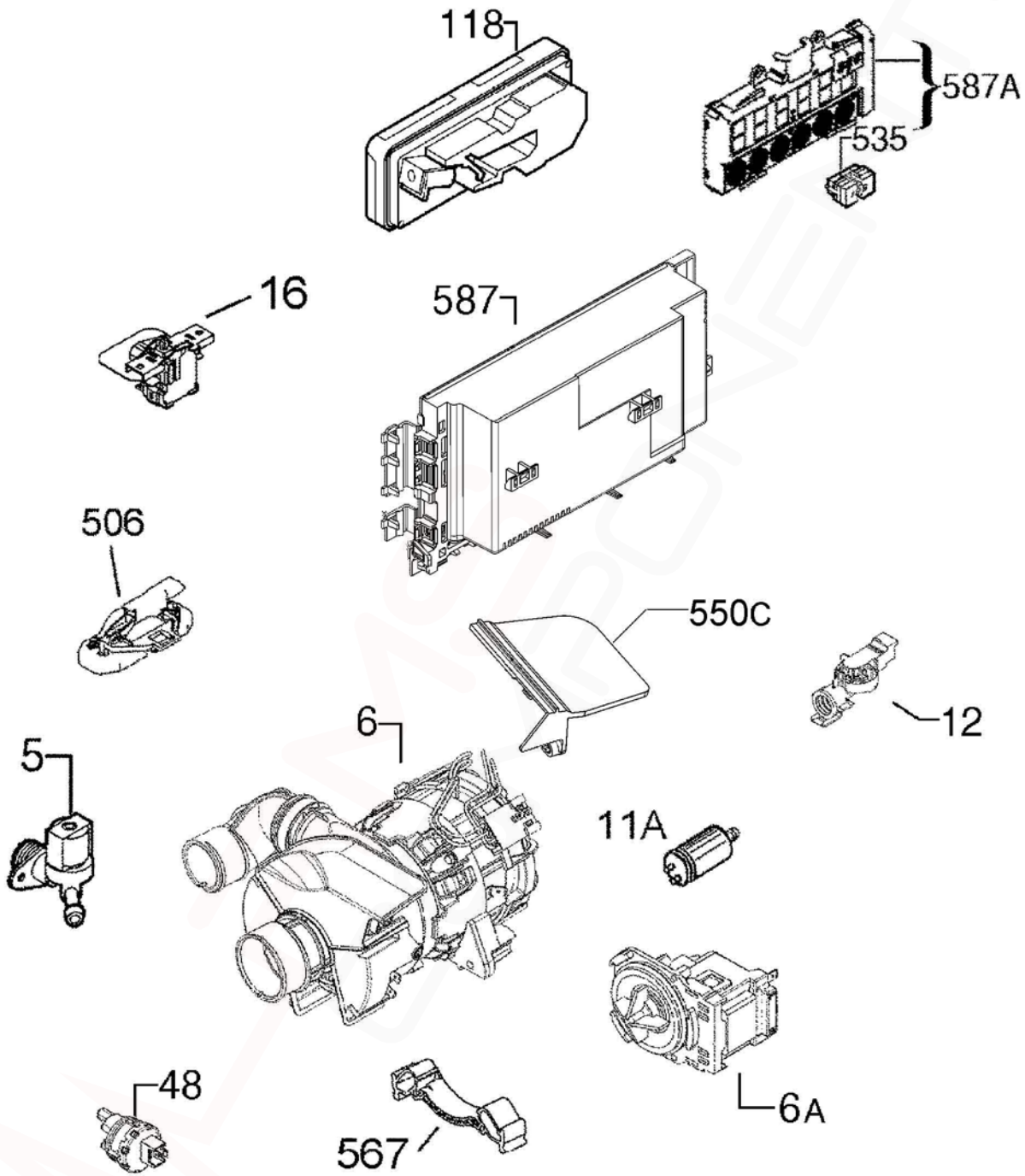

P09113205347

MODEL: DSF6305W**PNC 911516170 03****EX. VIEW P09113183466
ELECTRICAL COMPONENTS
ASSEMBLY**

ITEM	PART N°.	DESCRIPTION	EX. P09113183466	QTY
5	140001158017	Valve Fill 2 5Lt/min		1
6	140002106056	Pump Circulation Heater Comp 1800W		1
6A	140000443030	Pump Drain 50Hz		1
11A	1115927012	Capacitor Motor 3µf		1
12	140000554067	Switch Pressure Sensor		1
16	1113337024	Switch Main Auto OFF		1
48	140000401012	Sensor Temperature Turbidity		1
110C	1174356111	Hose Sump Pressure Sensor x212mm		1
118	1113330128	Dispenser Detergent C/R		1
506	140000565048	Switch Float Assembly		1
535	1119387007	Display LED 7mm		1
567	1171934019	Bracket Motor Buffer		2
587	973911516170033	PCB Configured Electronic		1
587A	1113367617	PCB User Interface Amber EDW1500		1
N.I.	140001945033	Cord Service AU 2 15m		1
N.I.	8074849012	Harness PCB Heater		1
N.I.	140008919015	Harness PCB Door		1
N.I.	8091583081	Harness PCB Pump		1

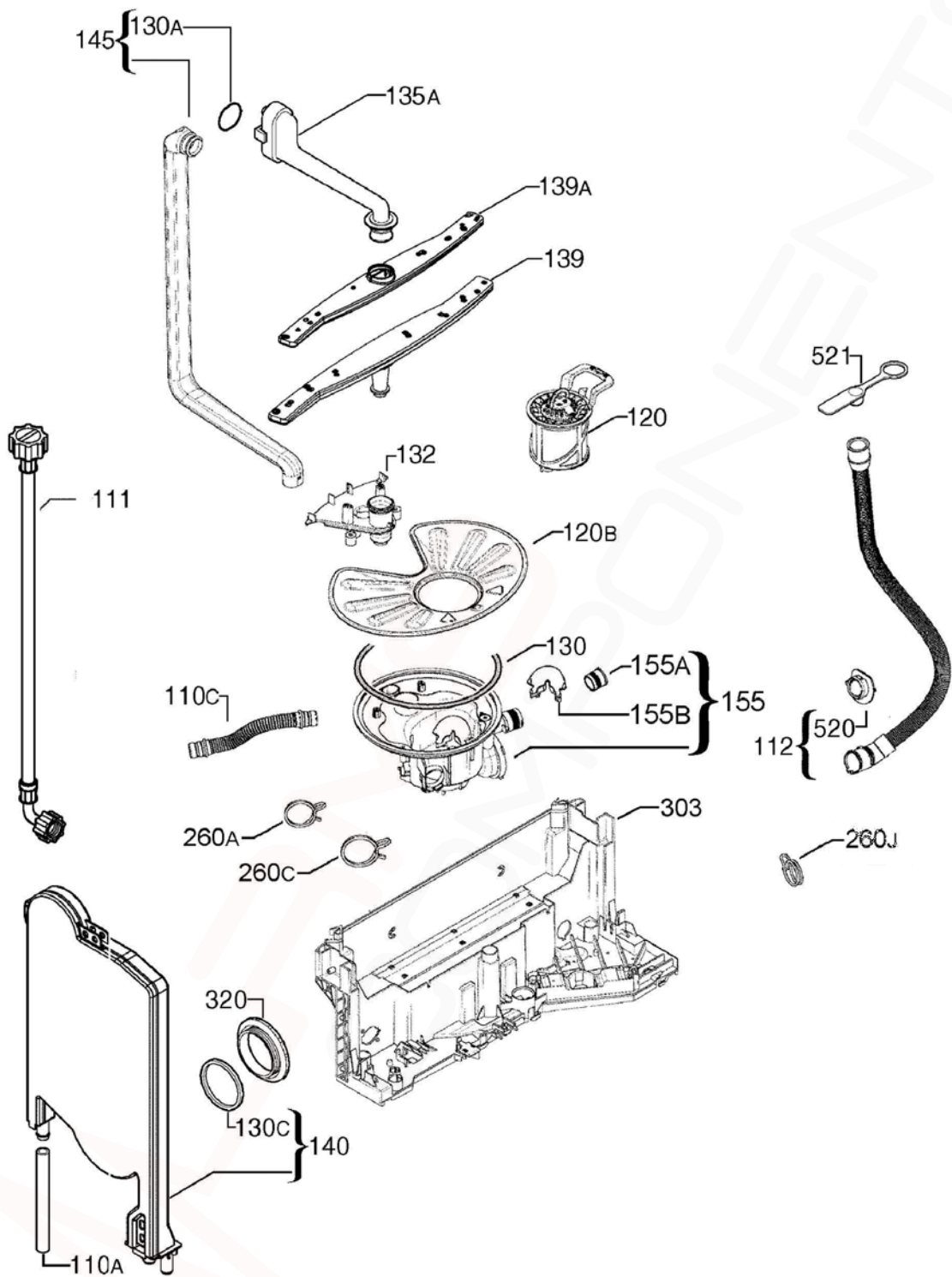

ITEM	PART N°.	DESCRIPTION	EX. P09113200077	QTY
110A	1526815-10/3	Tube Container Cup Fill Valve x280mm		1
110C	140000059034	Hose Sump Water Softener x370mm		1
111	1400000234030	Hose Feeder x1500mm		1
112	140010997017	Hose Drain x2230mm		1
120	8075472178	Filter Drain Grey Assembly		1
120B	1119209045	Filter Flat		1
130	1119186003	Sump O-Ring		1
130A	1523119-01/2	Seal Channel Drainage		1
130C	N.P.A.	Seal Round Container Cup		-
132	1119158176	Support Spray Arm Lower Dark Grey		1
135A	1561425370	Duct Light Grey 229.6mm		1
139	140000584072	Spray Arm Lower Light Grey		1
139A	1118949526	Spray Arm Upper Light Grey 450mm		1
140	1170481731	Container Cup Small		1
145	140000740021	Manifold Inner		1
155	140000494298	Sump Water Assembly with Air Trap		1
155A	140000536015	Valve Non-Return Flap Sump		1
155B	1119177010	Trap Sump Pump Drain		1
260A	8078689026	Clamp Circ Pump Flow Regulator Ø36mm		1
260C	8078689034	Clamp Circulation Pump Sump Ø45mm		1
260J	8078689018	Clamp Drain Hose Ø30mm		1
260K	8078689042	Clamp Ø16mm		1
303	140000531065	Basement Rear		1
320	1526272214	Vent Grill Dark Grey		1
520	N.P.A.	Flange Discharge Hose Ø20mm		-
521	N.P.A.	Stopper Drainage Hose		-

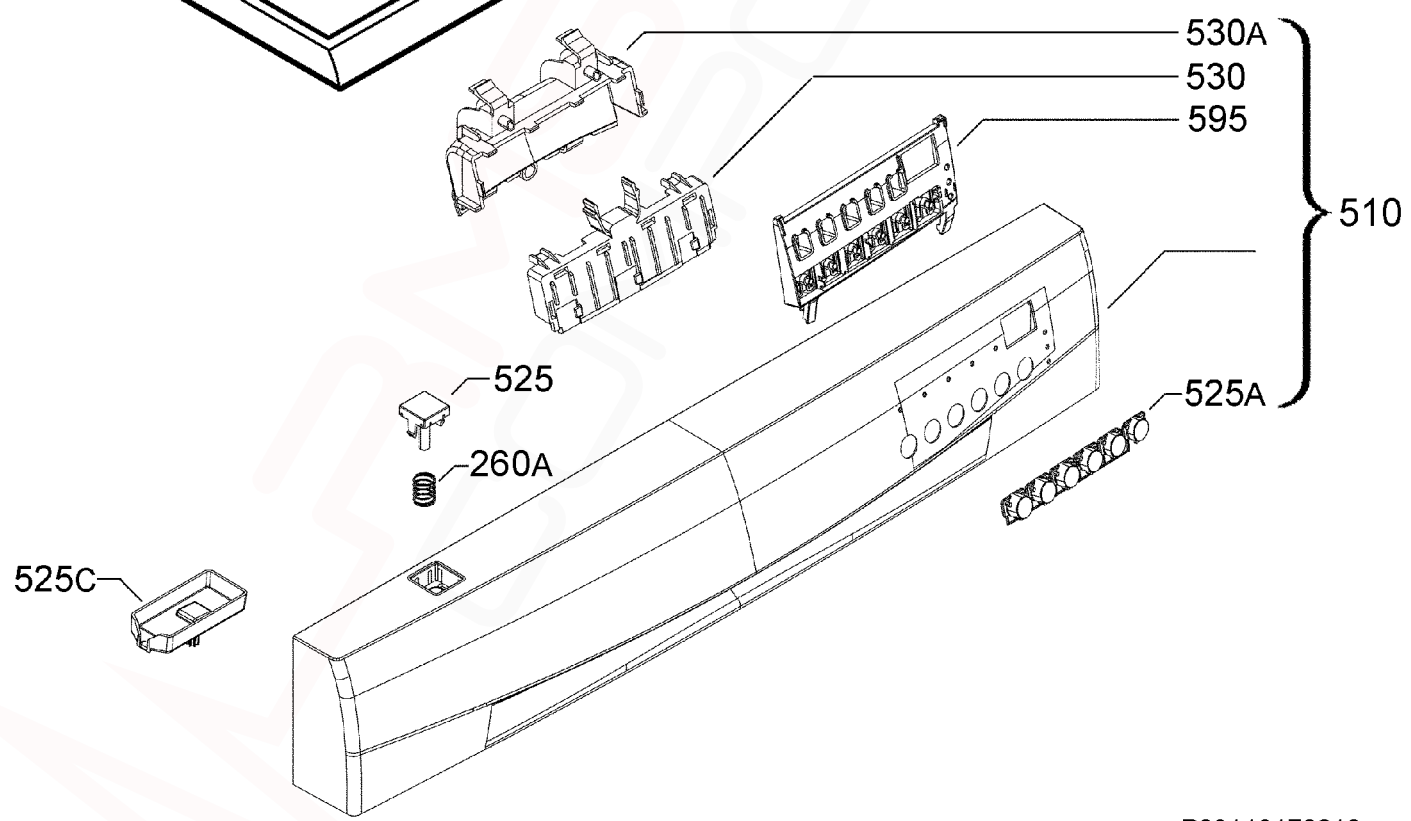
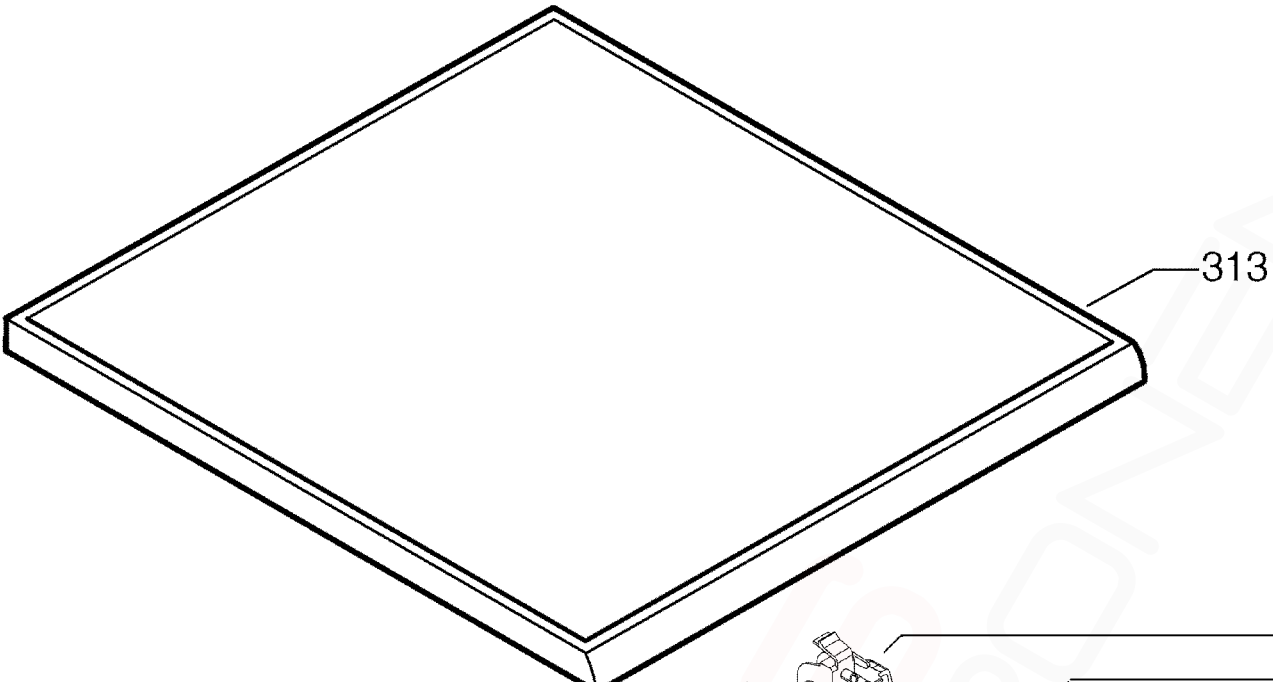

P09113187149

MODEL:**DSF6305W****PNC 911516170 03****EX. VIEW P09113176216
WORKTOP and CONTROL
PANEL ASSEMBLY**

ITEM	PART N°.	DESCRIPTION	EX. P09113176216	QTY
260A	1173192004	Spring Op/OØØ Button		1
313	1561348010	Work Top White		1
510	8086202028	Control Panel White DSF6305W		1
525	1173190008	Push Button On/Off White		1
525A	140002473019	Push Button Set 6 Button Wht		1
525C	1173189000	Push Button On/Off Protection		1
530	140002463010	Handle White		1
530A	140002464018	Handle Cover White		1
595	140002474017	Support Button Push		1
N.I.	5190530112	Screw Switch Housing 3.5x13 TTL		-

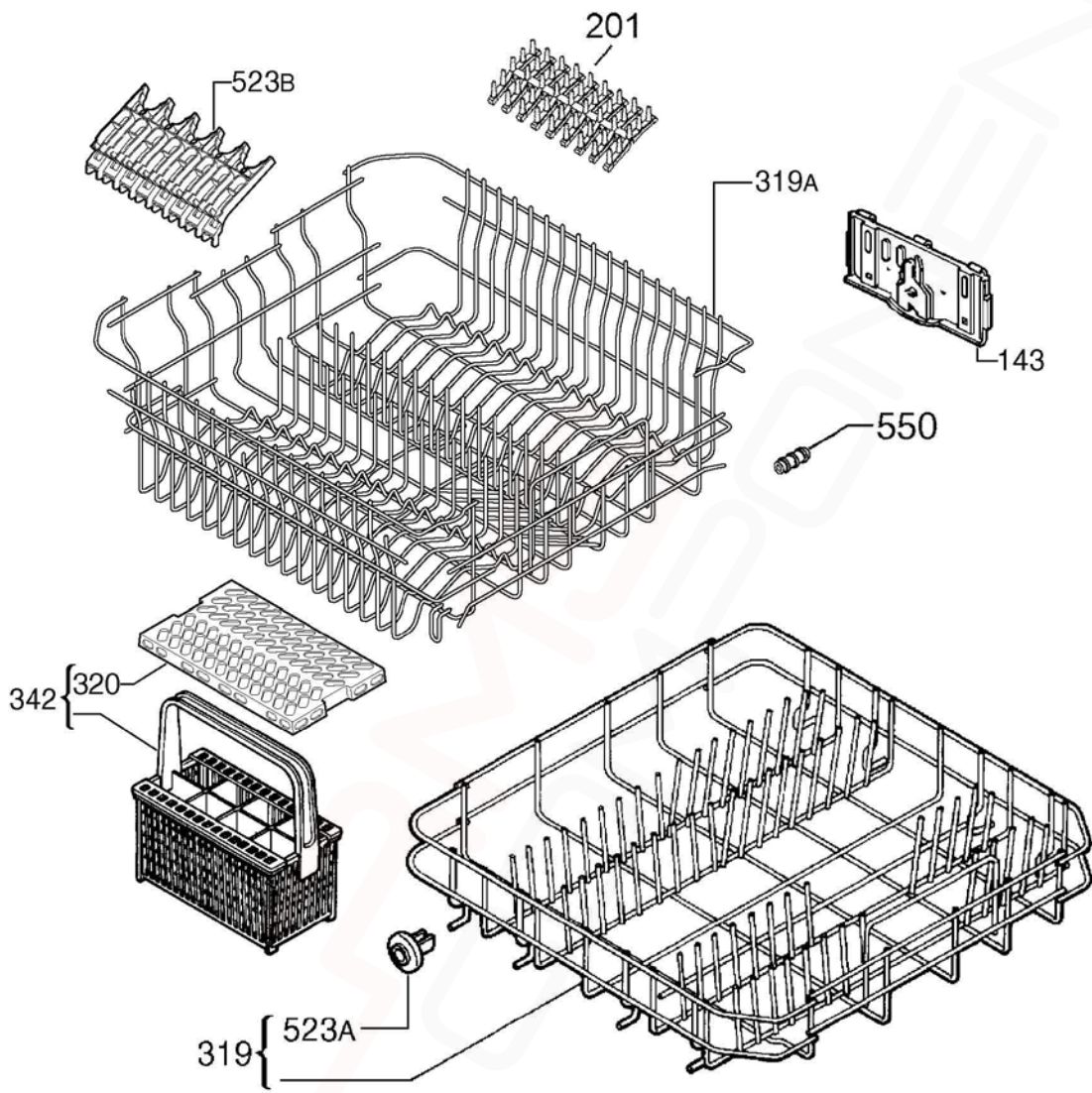

ITEM	PART N°.	DESCRIPTION	EX. P09113187041	QTY
143	1527359945	Plate Adjustment Right Hand		1
	1527359952	Plate Adjustment Left Hand		1
201	ACC088	Support Spikes Rubber Grey (2 per box)		1
319	1561446319	Basket Dishwasher Lower Assembly		1
319A	140000152037	Basket Upper Dishwasher Assy		1
320	N.P.A.	Grate Cutlery Basket Dark Grey		-
330	4055297552	Handle Basket Complete		2
342	ACC107	Basket Cutlery Universal (Inc. Item 320)		1
523A	50286965-00/4	Wheel Kit Basket Lower (8 Pieces)		1
523B	140001199029	Support Cup Grey		2
550	8996461804602	Buffer Rubber Dishwasher Upper		4
N.I.	140018976013	Hook Dispenser Upper Basket		1

DISHWASHER ACCESSORY COMPONENTS



ITEM	PART N°	DESCRIPTION
1	ACC017	Scalex Plus Descaler Sachet 75gm
2	ACC100	Detergent Dishwasher 1kg
3	ACC102	Rinse Aid Additive 500mls
4	ACC103	Descaler Powder 350g (Dangerous Goods rules apply, min order Qty of 12)
5	ACC002	Dishwasher Salt 1kg Pack
6	ACC088	Support Spikes Rubber – Grey
N.I.	ACC107	Basket Cutlery Universal
N.I.	0571400142	Hose Drain Extension Straight Cuffs 2m
N.I.	ES5323K	Hose Drain Extension Kit (1M Length)

P0000300001692	Legend
BASE BOARD	Main Electronic Board
BOF/BH	Indication Of Operation
CAPACITOR	Capacitor
DISPENSER	Detergent Dispenser
DOOR LOCK	Door Lock
DRAIN PUMP	Drain Pump
FLOW CONTROL	Flow Meter
HEATER	Heating Element
INLET VALVE	Inlet Valve
INPUT BOARD	User Interface (Display)
LEAKAGE SWITCH	Anti-Flooding Device
MAIN SWITCH	Main Switch
NTC/TURB. SENSOR	Turbidity Sensor
POWER CORD	Power Supply
PREASSURE SENSOR	Pressure Sensor
REG. VALVE	Regeneration Valve
RINSE AID	Resin Conditioning Water Switch
SALT AID	Salt
WASH PUMP	Washing Pump
GN/YE	Green/Yellow
RD	Red
BU	Blue
BR	Brown
BK	Black