



**ELECTROLUX HOME PRODUCTS PTY LTD**  
ABN 51 004 762 341

Technical Publication N° DW1011

Issue: 2  
Date: 08/17

***DISHLEX***  
***DOMESTIC HOUSEHOLD***  
***DISHWASHERS***

CONTENTS	PAGE N°
CABINET and BASE ASSEMBLY	2 & 3
DOOR ASSEMBLY	4 & 5
ELECTRICAL COMPONENTS	6 & 7
PUMP, SUMP and HYDRAULIC SYSTEM	8 & 9
CONTROL PANEL and WORK TOP ASSEMBLY	10 & 11
BASKET ASSEMBLY	12 & 13
AFTER MARKET ACCESSORIES	14
WIRING DIAGRAM, LEGEND and CIRCUIT DIAGRAM	15 - 17

NOTE: In Parts Listings

N.I. = Not Illustrated  
N.P.A. = No Part Available  
N.P.N. = Not Used on this Model

***MODEL:***

***DSF6205W***

***PNC:***

***911513132 01***

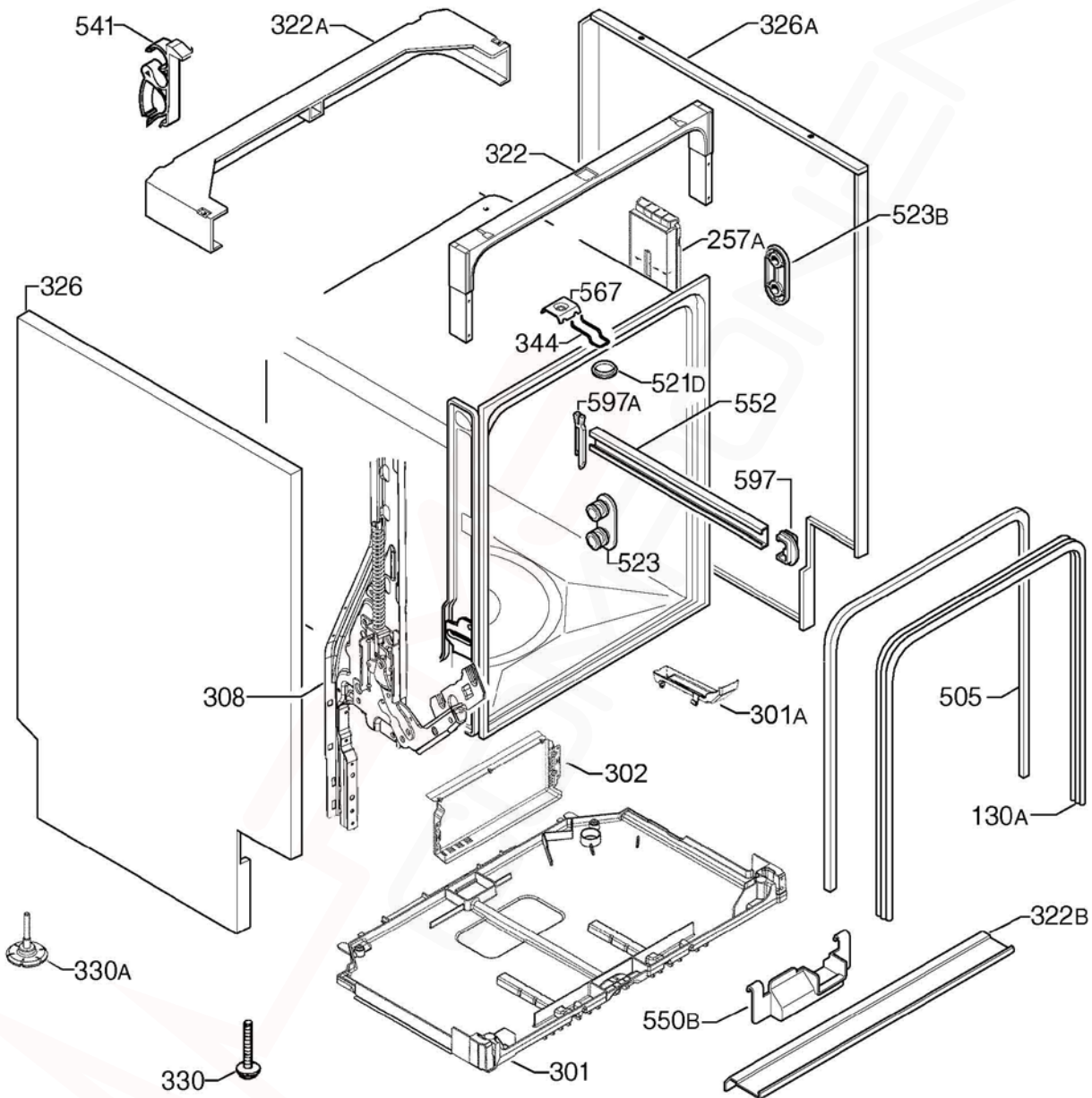

<b>ITEM</b>	<b>PART N°.</b>	<b>DESCRIPTION</b>	<b>EX. P09113178362</b>	<b>QTY</b>
130A	<b>1171265026</b>	Gasket Door Outer 1730mm		1
257A	<b>N.P.A.</b>	Counterweight Side Dishwasher		-
301	<b>140000527014</b>	Tray Bottom Spillage		1
301A	<b>4055250858</b>	Kit Overflow Hose		1
302	<b>140000750012</b>	Cover Electronic PCB - Metal		1
308	<b>4055161352</b>	Kit Hinge Left-Right		1
322	<b>1560799114</b>	Brace Front Upper Zinc - Plated		1
322A	<b>1170350043</b>	Brace Rear Upper		1
322B	<b>140000212039</b>	Brace Front Lower		1
326	<b>1170153421</b>	Panel Side Left - White		1
326A	<b>1170153520</b>	Panel Side Right - White		1
330	<b>1520664-10/1</b>	Foot Adjustable Ø36mm		2
330A	<b>8075188014</b>	Foot Adjustable Ø48mm		2
344	<b>1522344-05/8</b>	Latch Door Lock		1
505	<b>1526715410</b>	Trimming Tub Black		1
521D	<b>1526576-00/2</b>	Hole Cover Latch		1
523	<b>50299970009</b>	Wheel Support Kit Dark Grey (4 Pieces)		1
523B	<b>1118814-00/1</b>	Stiffening Support		4
541	<b>N.P.A.</b>	Hose Clamp		-
550B	<b>1522345071</b>	Cover Wiring Protection		1
552	<b>140003656026</b>	Rail Basket Upper Complete		2
567	<b>1523236-03/0</b>	Clip Speed (Plaque)		1
597	<b>1520479419</b>	Stop Basket Front Dark Grey		2
597A	<b>6461234061</b>	Stop Basket Back Dark Grey		2

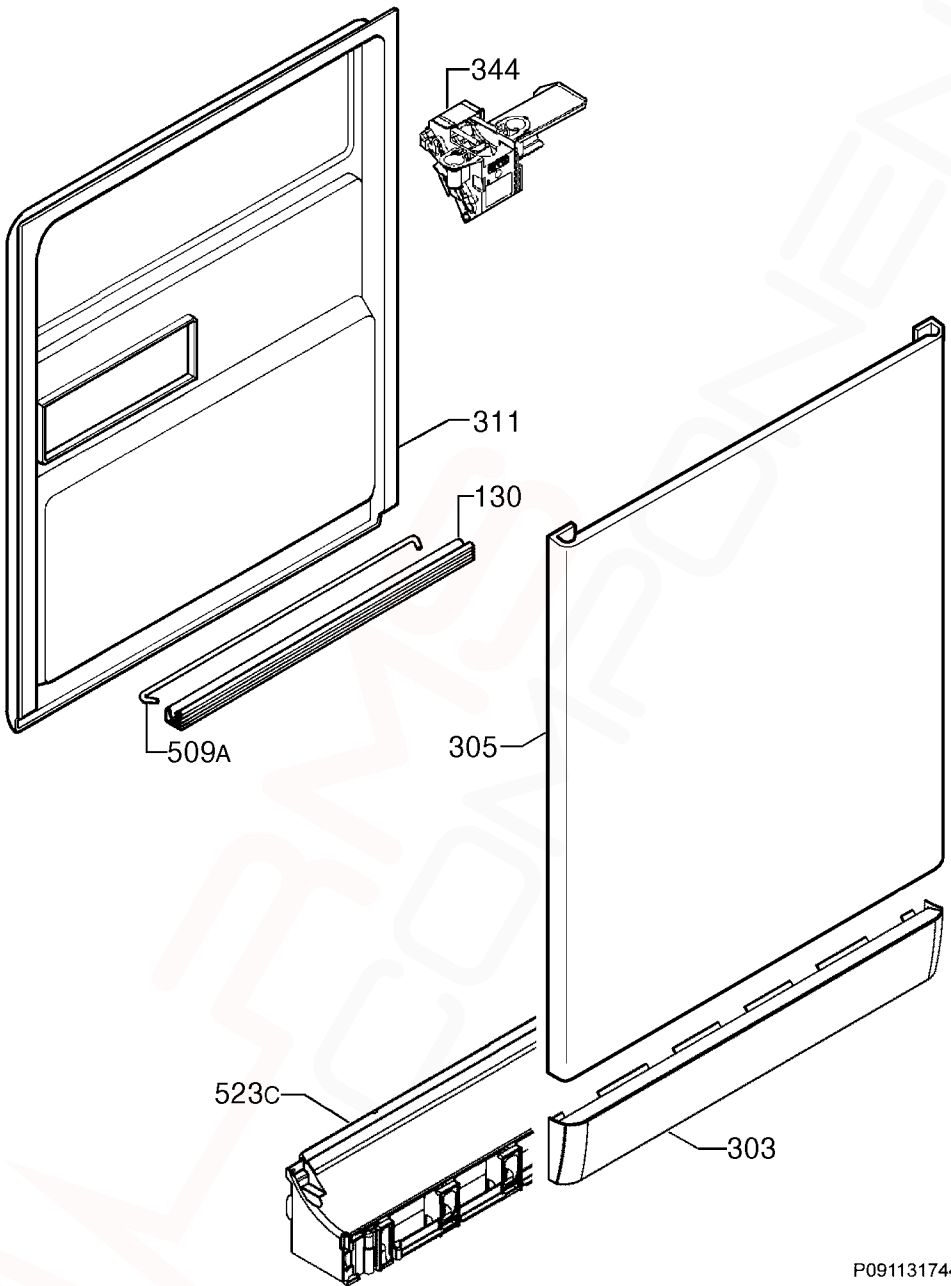

P09113201220

**MODELS: DSF6205W**

**PNC 911513132 01**

**EX. VIEW P09113174465  
DOOR ASSEMBLY**

<b>ITEM</b>	<b>PART N°.</b>	<b>DESCRIPTION</b>	<b>EX. P09113174465</b>	<b>QTY</b>
130	<b>1527401-00/2</b>	Gasket Door Lower Blk x 550mm		1
303	<b>8070407039</b>	Plinth White		1
305	<b>1561221464</b>	Panel Door Outer - White		1
311	<b>140025959028</b>	Panel Door Inner		1
344	<b>1113150120</b>	Latch Door Complete		1
509A	<b>1520419-14/2</b>	Tie Hinge		1
523C	<b>1170156-03/6</b>	Holder Plinth - Dark Grey		1

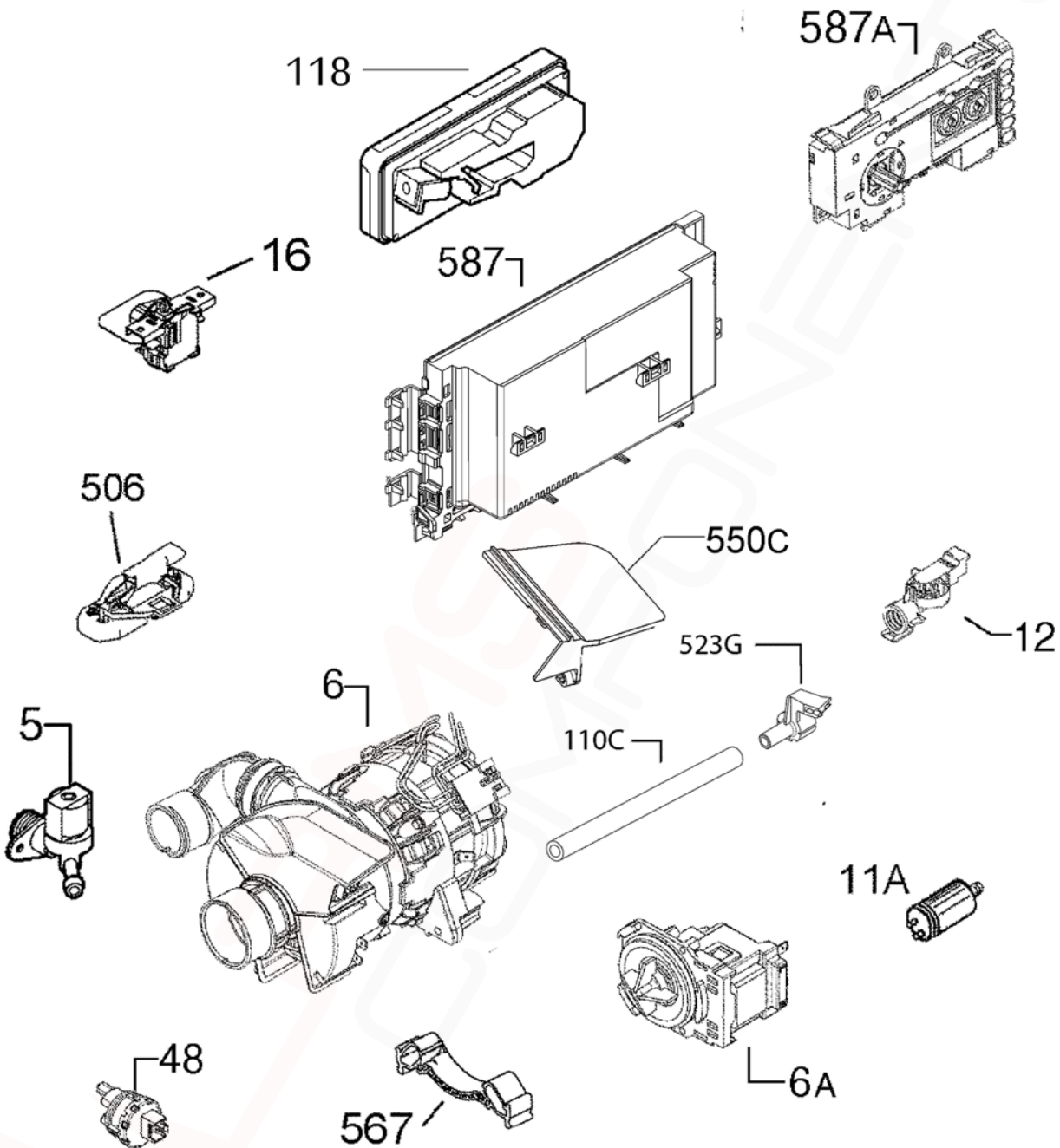

P09113192424

<b>ITEM</b>	<b>PART N°.</b>	<b>DESCRIPTION</b>	<b>EX. P09113192424</b>	<b>QTY</b>
5	<b>140001158017</b>	Valve Fill 2 5Lt/min		1
6	<b>140002106056</b>	Pump Circulation Heater Comp 1800W		1
6A	<b>140000443030</b>	Pump Drain 50Hz		1
11A	<b>1115927012</b>	Capacitor Motor 3µf		1
12	<b>140000554067</b>	Switch Pressure		1
16	<b>1113337024</b>	Switch Main Auto OFF		1
48	<b>140000401012</b>	Sensor Temperature Turbidity		1
110C	<b>1174356111</b>	Hose Sump Pressure Sensor x 212mm		1
118	<b>1113330128</b>	Dispenser Detergent C/R		1
506	<b>140000565048</b>	Switch Float Assembly		1
523G	<b>140026130017</b>	Adaptor Switch Pressure Sensor		1
550C	<b>8080890018</b>	Cover Motor Drip Prevention		1
567	<b>1171934019</b>	Bracket Motor Buffer		2
587	<b>973911513132010</b>	Board Configured Electronic,PB200		1
587A	<b>1113381329</b>	PCB User Interface Amber EDW750		1
N.I.	<b>140001945033</b>	Cord Service AU 2.15m		1
N.I.	<b>8074849012</b>	Harness PCB Heater		1
N.I.	<b>140008919015</b>	Harness PCB Door		1
N.I.	<b>8091583081</b>	Harness PCB Pump		1

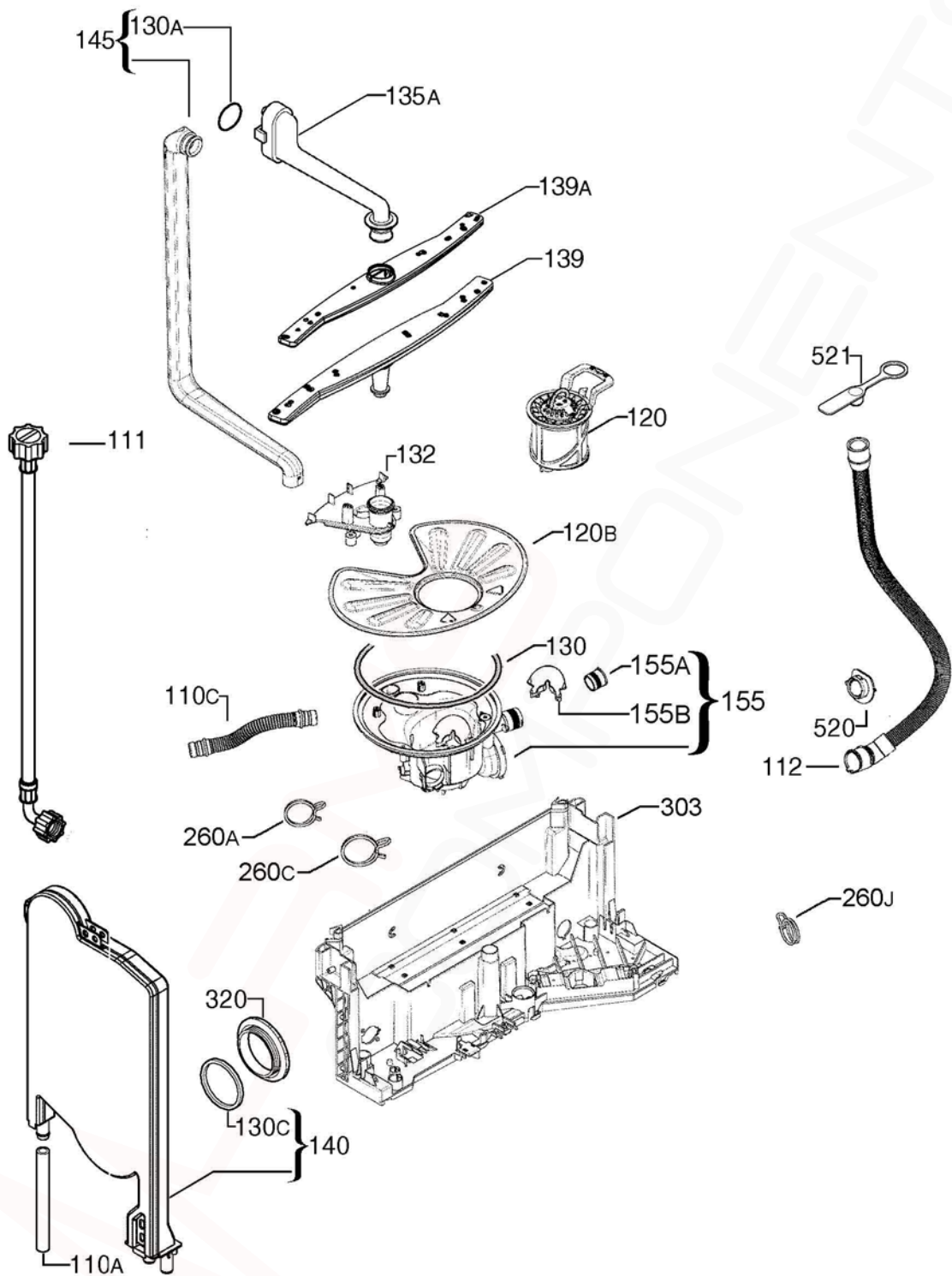



<b>ITEM</b>	<b>PART N°.</b>	<b>DESCRIPTION</b>	<b>EX. P09113192425</b>	<b>QTY</b>
110A	<b>1526815-10/3</b>	Tube Container Cup Fill Valve x 280mm		1
110C	<b>140000059034</b>	Hose Sump Water Softener x 370mm		1
111	<b>1400000234030</b>	Hose Feeder x 1500mm		1
112	<b>140005633056</b>	Hose Drain x 2240mm		1
120	<b>8075472012</b>	Filter Drain Assembly		1
120B	<b>1119209045</b>	Filter Flat		1
130	<b>1119186003</b>	Sump O-Ring		1
130A	<b>1523119-01/2</b>	Seal Channel Drainage		1
130C	<b>N.P.A.</b>	Seal Round Container Cup		-
132	<b>1119158176</b>	Support Spray Arm Lower		1
135A	<b>1561425370</b>	Channel Feed Upper Spray Arm		1
139	<b>140000584072</b>	Spray Arm Lower Dark Grey		1
139A	<b>1118949526</b>	Spray Arm Upper Dark Grey		1
140	<b>1170481731</b>	Container Cup Small		1
145	<b>140000740013</b>	Tube Manifold Inner Dark Grey		1
155	<b>140000494215</b>	Sump Assembly		1
155A	<b>140000536015</b>	Valve Non-Return Flap Sump		1
155B	<b>1119177010</b>	Trap Sump Pump Drain		1
260A	<b>8078689026</b>	Clamp Circ Pump Flow Regulator Ø36mm		1
260C	<b>8078689034</b>	Clamp Circulation Pump Sump Ø45mm		1
260J	<b>8078689018</b>	Clamp Drain Hose Ø30mm		1
260K	<b>8078689042</b>	Clamp Ø16mm		
303	<b>140000531032</b>	Basement Rear		1
320	<b>1526272214</b>	Vent Grill Dark Grey		1
520	<b>N.P.A.</b>	Flange Discharge Hose Ø20mm		-
521	<b>N.P.A.</b>	Stopper Drainage Hose		-

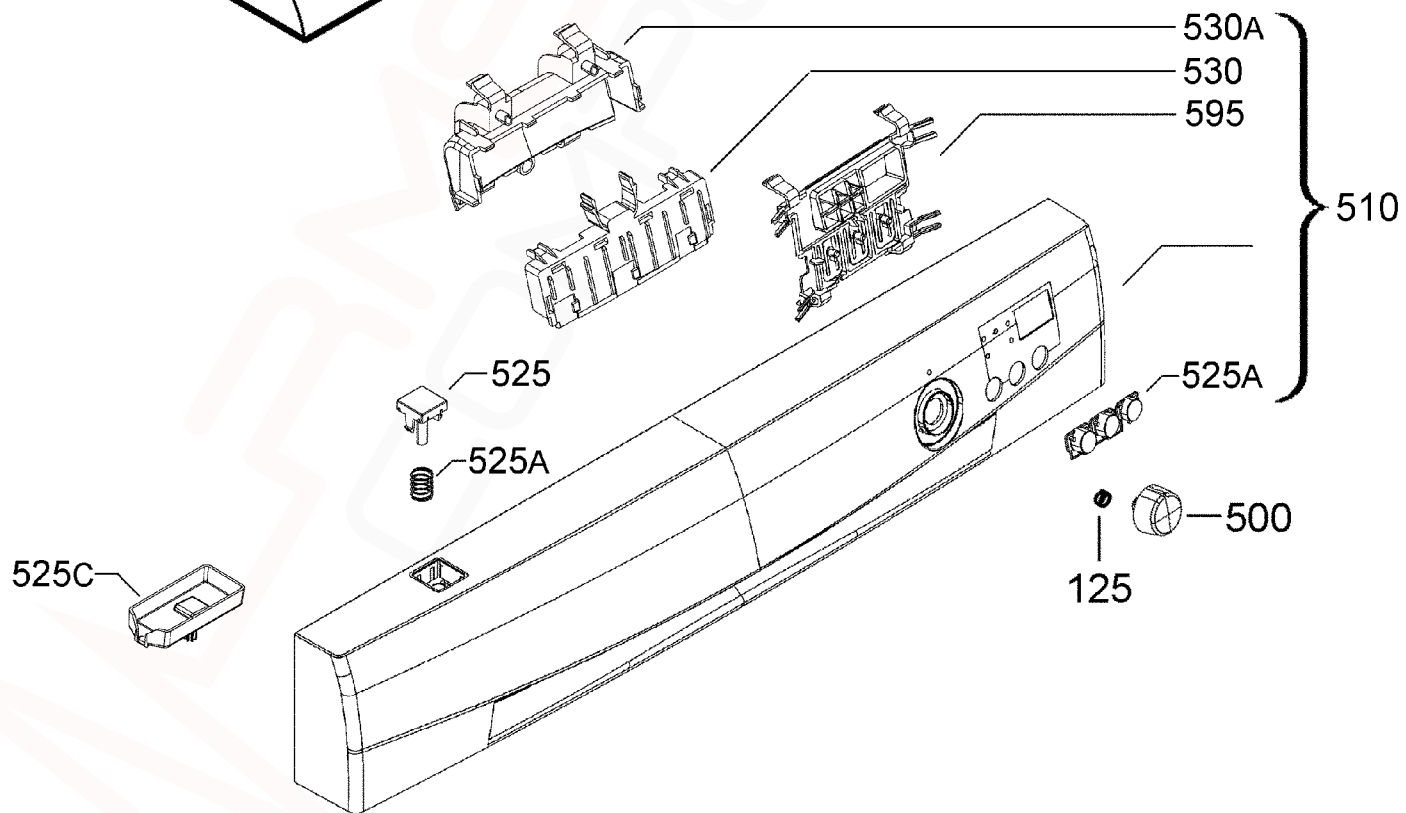
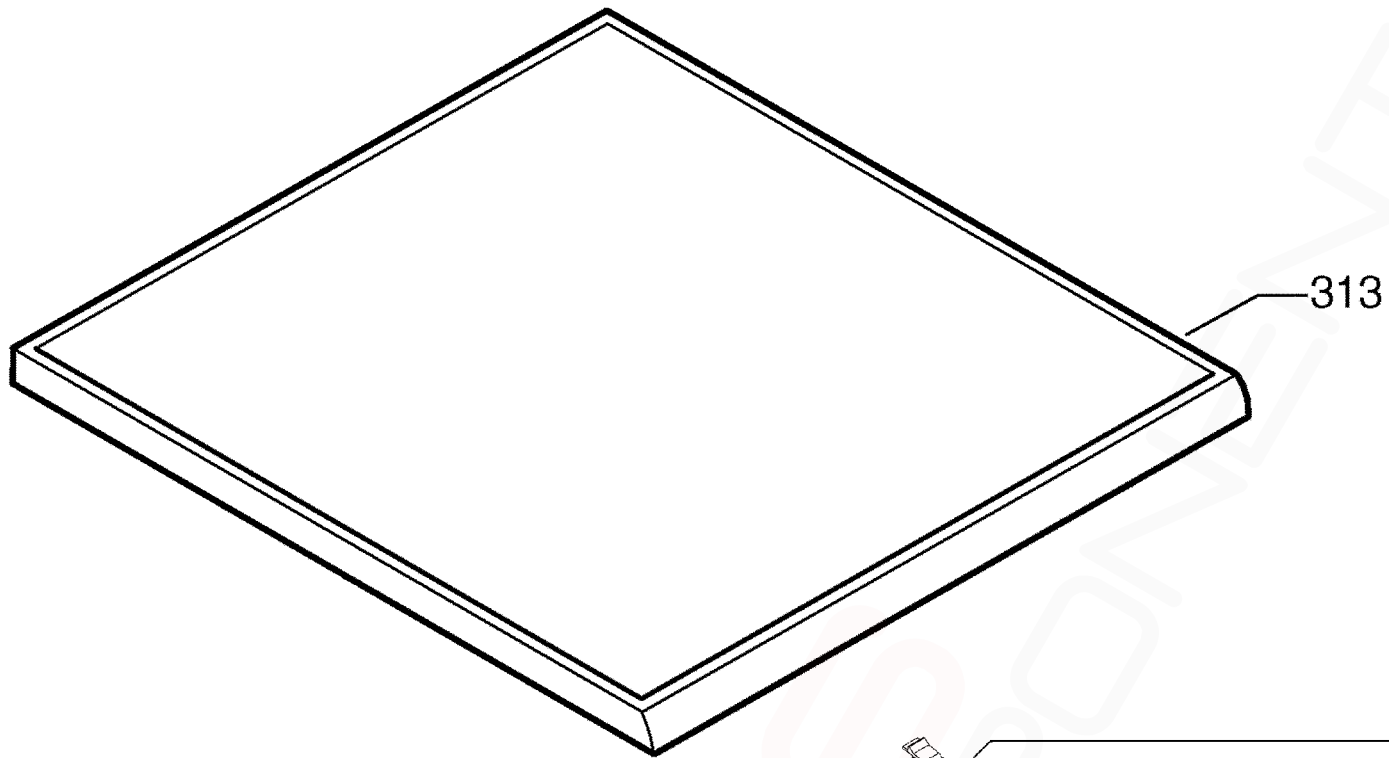

P09113187143

**MODELS:****DSF6205W****PNC 911513132 01****EX. VIEW P09113176272  
WORKTOP and CONTROL  
PANEL ASSEMBLY**

<b>ITEM</b>	<b>PART N°.</b>	<b>DESCRIPTION</b>	<b>EX. P09113176272</b>	<b>QTY</b>
125	<b>1520227016</b>	Knob Spring		1
260A	<b>1173192004</b>	Spring On/Off Button		1
313	<b>1561348010</b>	Work Top White		1
500	<b>140002456014</b>	Knob White		1
510	<b>8086323022</b>	Control Panel White DSF6205W		1
525	<b>1173190008</b>	Push Button On/Off White		1
525A	<b>140002466013</b>	Push Button Set 3 Button Wht		1
525C	<b>1173189000</b>	Push Button On/Off Protection		1
530	<b>140002463010</b>	Handle White		1
530A	<b>140002464018</b>	Handle Cover White		1
595	<b>140002468019</b>	Support Button Push		1
N.I.	<b>5190530112</b>	Screw Switch Housing 3.5x13 TTL		-

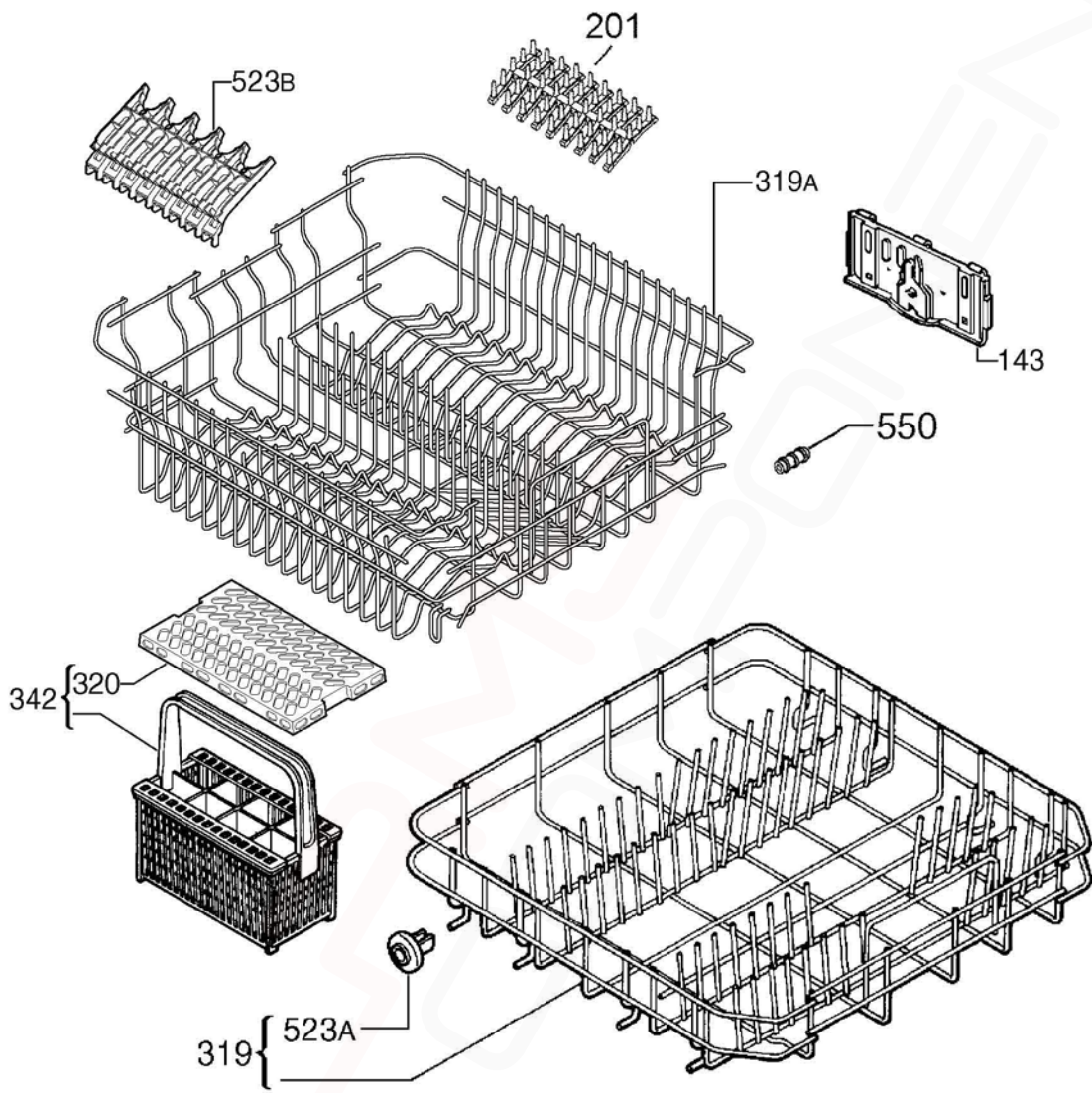

<b>ITEM</b>	<b>PART N°.</b>	<b>DESCRIPTION</b>	<b>EX. P09113187041</b>	<b>QTY</b>
143	<b>1527359945</b>	Plate Adjustment Right Hand		1
	<b>1527359952</b>	Plate Adjustment Left Hand		1
201	<b>1380184109</b>	Support Spikes Rubber Grey		2
319	<b>1561294057</b>	Basket Dishwasher Bottom Assembly		1
319A	<b>1561219005</b>	Basket Dishwasher Upper Light Grey		1
320	<b>N.P.A.</b>	Grate Cutlery Basket Grey		-
342	<b>ACC107</b>	Basket Cutlery Universal (Incl. Item 320)		1
523A	<b>50286965-00/4</b>	Wheel Kit Basket Lower (8 Pieces)		1
523B	<b>ACC088</b>	Support Spikes Rubber – Grey		1
550	<b>8070264018</b>	Buffer Rubber Dishwasher Upper		2
N.I.	<b>1561218007</b>	Hook Dispenser Upper Basket		1

**DISHWASHER  
ACCESSORY COMPONENTS**



ITEM	PART N°	DESCRIPTION
1	ACC017	Scalex Plus Descaler Sachet 75gm
2	ACC100	Detergent Dishwasher 1kg
3	ACC102	Rinse Aid Additive 500mls
4	ACC103	Descaler Powder 350g <b>(Dangerous Goods rules apply, min order Qty of 12)</b>
5	ACC002	Dishwasher Salt 1kg Pack
6	ACC088	Support Spikes Rubber – Grey

<b>P0000300001692</b>	<b>Legend</b>
BASE BOARD	Main Electronic Board
BOF/BH	Indication Of Operation
CAPACITOR	Capacitor
DISPENSER	Detergent Dispenser
DOOR LOCK	Door Lock
DRAIN PUMP	Drain Pump
FLOW CONTROL	Flow Meter
HEATER	Heating Element
INLET VALVE	Inlet Valve
INPUT BOARD	User Interface (Display)
LEAKAGE SWITCH	Anti-Flooding Device
MAIN SWITCH	Main Switch
NTC/TURB. SENSOR	Turbidity Sensor
POWER CORD	Power Supply
PREASSURE SENSOR	Pressure Sensor
REG. VALVE	Regeneration Valve
RINSE AID	Resin Conditioning Water Switch
SALT AID	Salt
WASH PUMP	Washing Pump
GN/YE	Green/Yellow
RD	Red
BU	Blue
BR	Brown
BK	Black