

Electrolux

ELECTROLUX HOME PRODUCTS PTY LTD

ABN 51 004 762 341

Technical Publication N° DW1115

Issue: 2

Date: 01/19

Dishlex

DOMESTIC HOUSEHOLD FREE STANDING DISHWASHER

CONTENTS	PAGE
CABINET and BASE ASSEMBLY	2
DOOR ASSEMBLY	4
ELECTRICAL COMPONENTS	6
PUMP, SUMP and HYRAULIC SYSTEM	8
CONTROL PANEL	10
BASKET ASSEMBLY	12
WIRING DIAGRAM	14
CIRCUIT DIAGRAM	15

NOTE: In Parts Listings

N.I.	=	Not Illustrated
N.P.A.	=	No Part Available
N.P.N.	=	Not Used on this Model

MODEL:

DSF6106W

PNC: 911519240 00

DSF6106X

PNC: 911519241 00

MODEL: DSF6106W and DSF6106X
CABINET and BASE ASSEMBLY

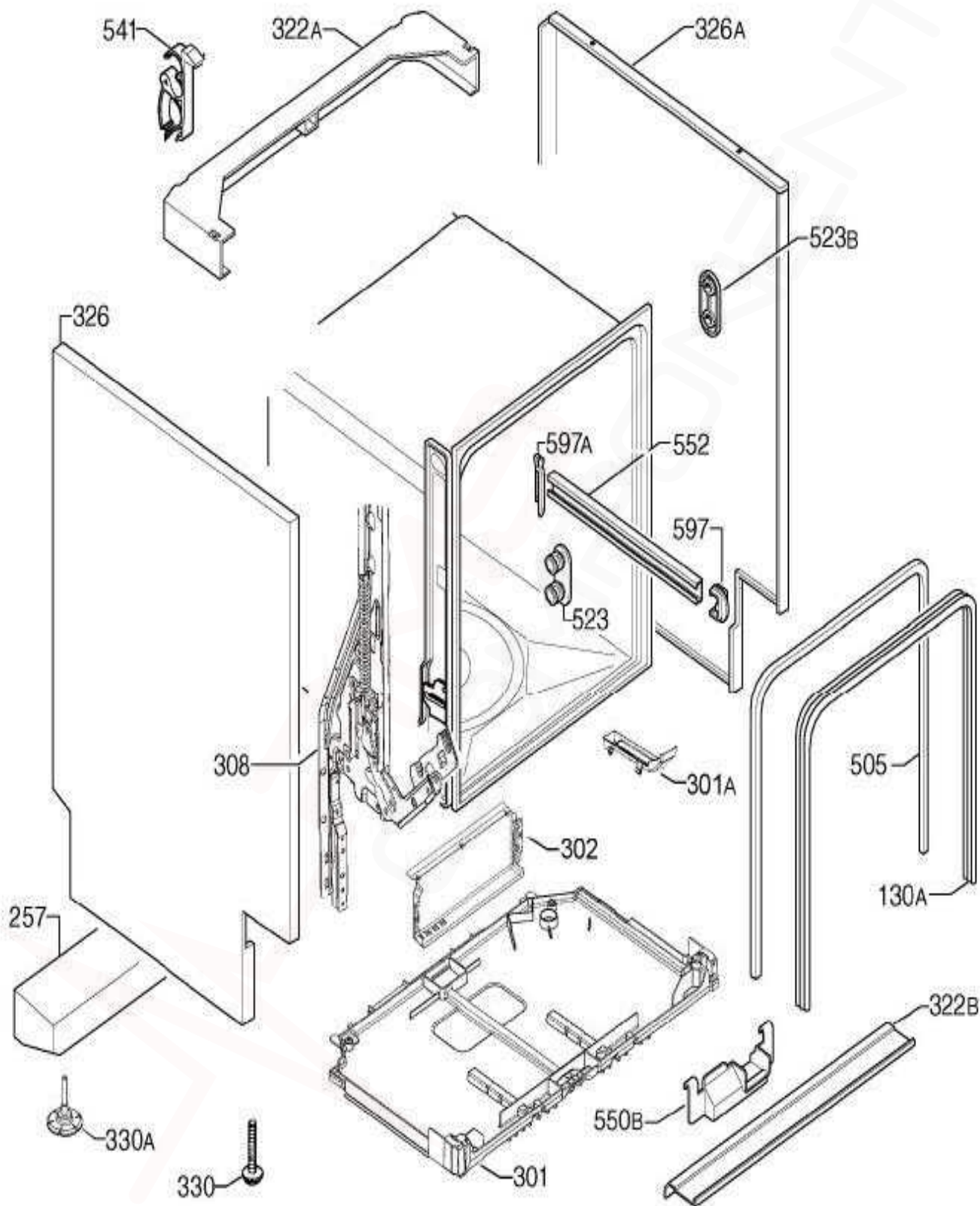

ITEM	PART No.	DESCRIPTION	QTY 6106W	QTY 6106X
130A	1171265448	Sealing, outer, L=1730mm	1	1
257	NPA	Counterweight,2,2kg	1	1
301	140000527113	Bottom tray	1	1
301A	4055250858	Kit, overflow hose, conveyor	1	1
302	140000750012	Cover, electronic, metal	1	1
308	4055425187	Hinge, assembly, left-right	1	1
322A	1170350050	Crossbar, rear, upper	1	1
322B	140000212039	Cross piece, front, bottom	1	1
326	140058001011	Side panel, left,white,519x808mm	1	
326	140058001052	Side panel, left, inox,519x808mm		1
326A	140058001029	Side panel, right, white,519x808mm	1	
326A	140058001060	Side panel, right, inox,519x808mm		1
330	1520664101	Adjustable foot,36x18mm	1	1
330A	8075188014	Adjustable foot,M8x48mm	1	1
505	1526715410	Trimming, tub, black	1	1
523	4055260790	Wheel support kit, dark grey, 4 pcs.	1	1
523B	1118814-00/1	Stiffening, Support	1	1
541	1526417009	Hose holder	1	1
550B	1522345071	Wiring protection	1	1
552	140101683021	Basket rail, upper	1	1
597	1520479419	Basket stop, front, dark grey	1	1
597A	6461234061	Stopper, back, dark grey	1	1
NI	4055046587	Clip, Rivet, stud, 24.5 x 5.8mm, 4 pcs.	1	1
NI	4055401972	Screw, hinge, Kit,10x, T20, 10mm	1	1

MODEL: DSF6106W and DSF6106X

DOOR ASSEMBLY

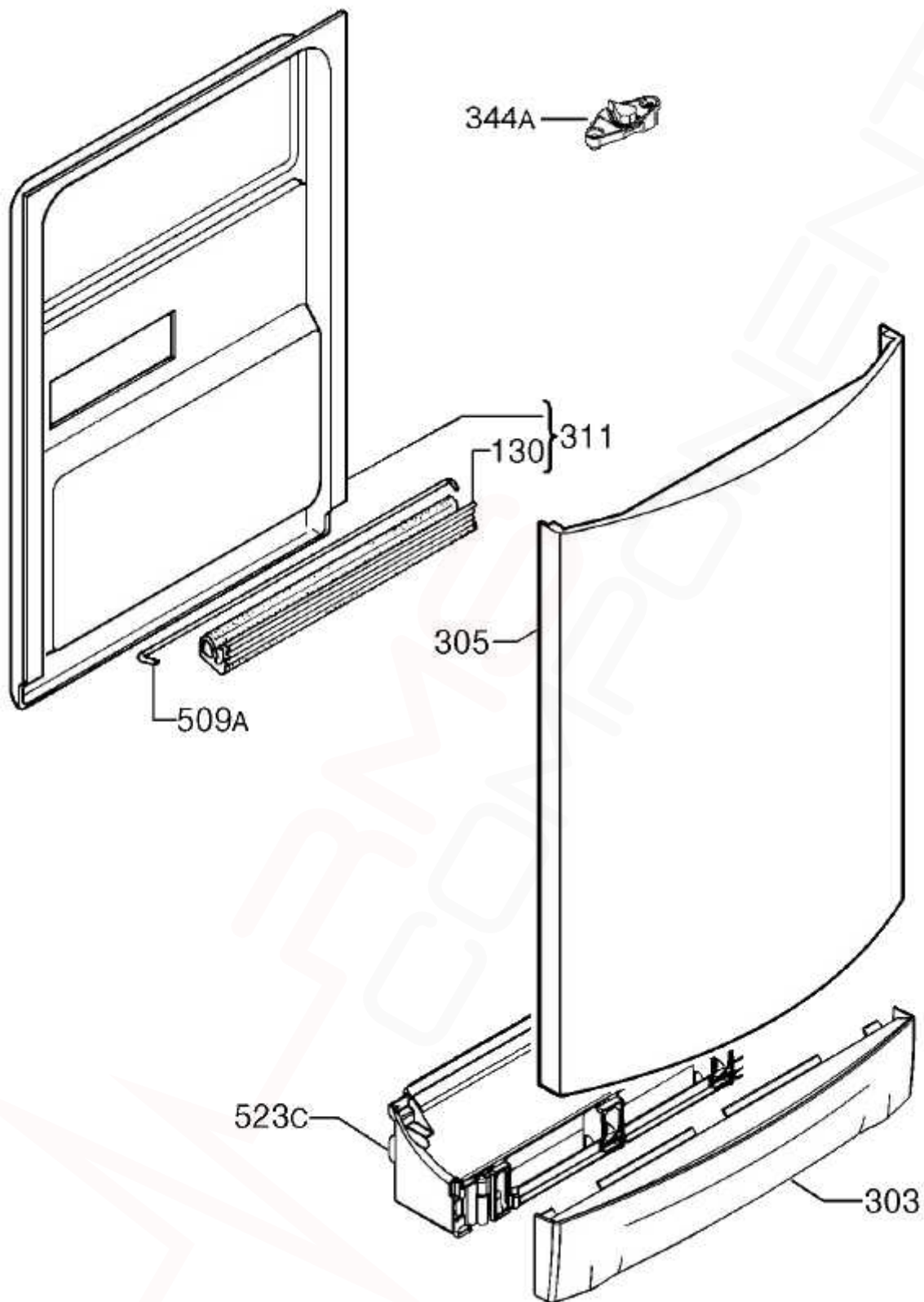

ITEM	PART No.	DESCRIPTION	QTY 6106W	QTY 6106X
130	1527401002	Door gasket, bottom, black, L=550	1	1
303	8070407039	Plinth, white	1	
303	8070407013	Plinth, inox		1
305	1561221464	Outer door, white, 60	1	1
305	1561221456	Outer door, inox, 60		1
311	140025959051	Inner door,577 x 617mm	1	1
344A	140035300064	Latch	1	1
509A	1520419142	Tie, hinge	1	1
523C	1170156036	Holder, plinth dark grey	1	1

MODEL: DSF6106W and DSF6106X

ELECTRICAL COMPONENTS

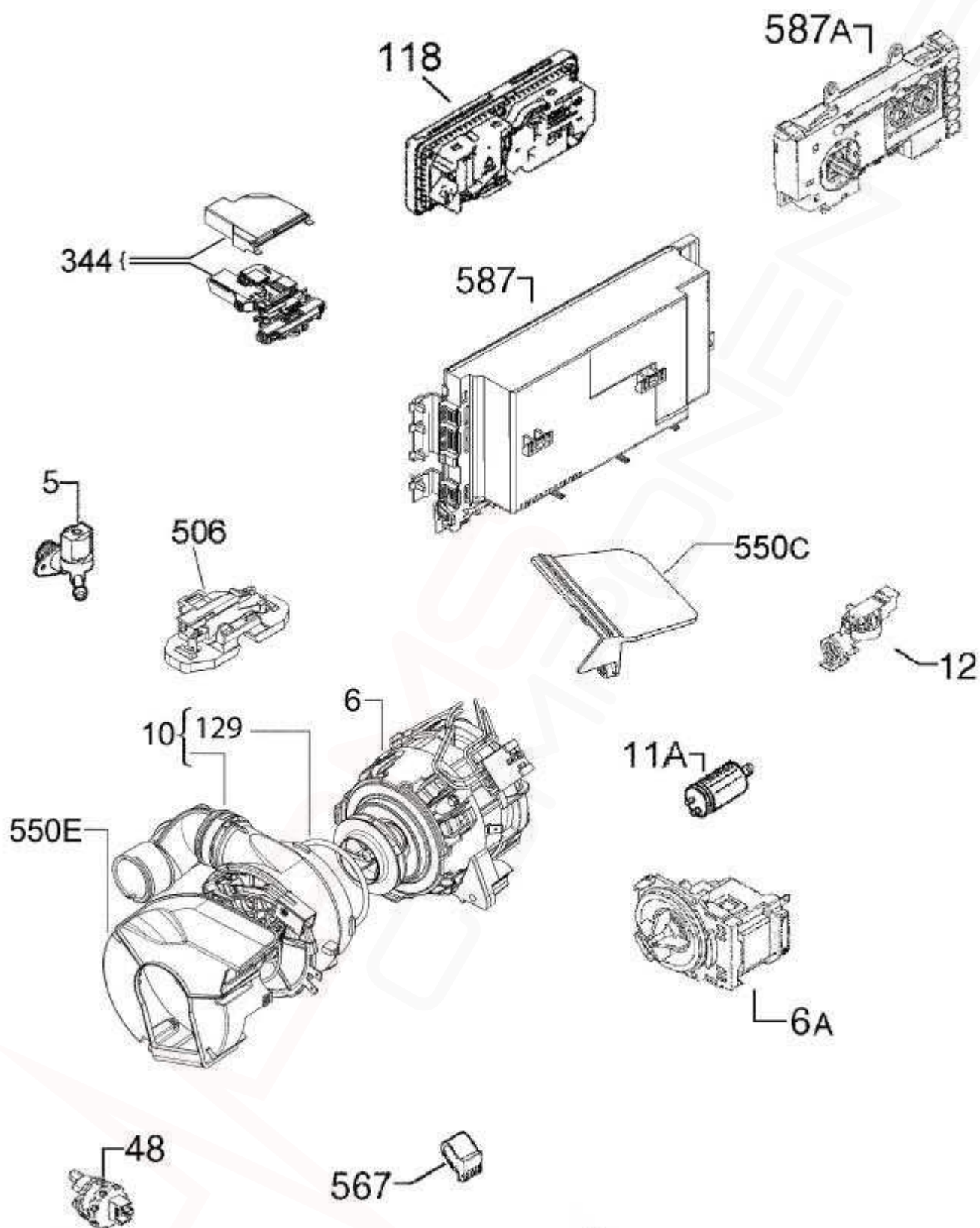

© Electrolux

ITEM	PART No.	DESCRIPTION	QTY 6106W	QTY 6106X
005	140001158025	Fill valve,2,5l/min,180'outlet	1	1
006	140002105025	Circulation pump,ASYNC,90W	1	1
006A	140000443030	Drain pump,without,Hose,50Hz	1	1
10	140002162190	Heater,with,o-ring,230V/1800W	1	1
011A	1115927012	Capacitor,motor,3 uF	1	1
12	140000554083	Pressure switch	1	1
48	140000401012	Turbidity sensor, with, gasket	1	1
118	140000775019	Dispenser,detergent,reed,DIVA2	1	1
129	140039688019	O-ring, heater, circulation pump,58x3,6mm	1	1
344	4055425179	Door lock, without, door opener,50N	1	1
506	140000565048	Float switch, assembly	1	1
550C	8080890018	Drip protection, motor	1	1
550E	140002173031	Cover, heater	1	1
567	1173024009	Motor support, rubber	1	1
587	140006214088B	Board PCB programmed PB300-DSF6106	1	1
587A	140000423594	User interface board,amber,EDW500	1	1
NI	140001945033	Power cable, Australia 2,15m	1	1
NI	140070301019	Harness, PCB, Pump,(A)	1	1
NI	140070302017	Harness, PCB, door,(B)	1	1
NI	8074849012	Harness, PCB, heater,(C)	1	1

MODEL: DSF6106W and DSF6106X
PUMP, SUMP and HYDRAULIC SYSTEM

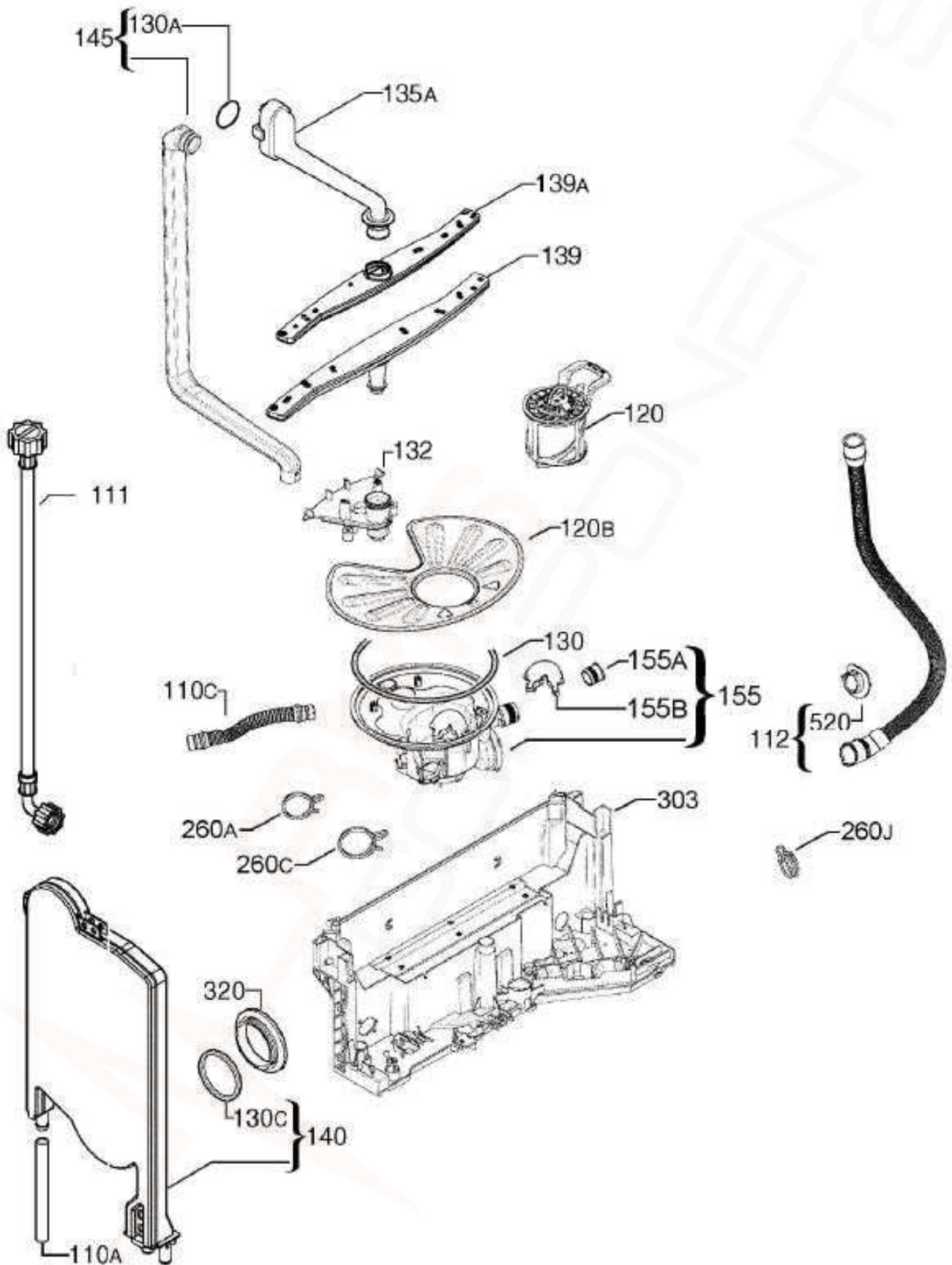

ITEM	PART No.	DESCRIPTION	QTY 6106W	QTY 6106X
110A	1526815103	Tube, Container cup, fill valve, L=280	1	1
110C	140000059034	Hose, sump, tank, L=370mm	1	1
111	1400000234030	Feeder hose,L-1500	1	1
112	140010997017	Drain hose, L=2230mm	1	1
120	8075472269	Drain filter, grey, assembly	1	1
120B	8084297046	Filter, flat, Indicator	1	1
130	1119186003	O-ring, sump	1	1
130A	1523119012	Seal, Channel drainage	1	1
130C	50659231000	Round seal, Container cup	1	1
132	1119158176	Lower spray arm, Support, dark grey	1	1
135A	1561425370	Duct, grey, L = 229,6mm	1	1
139	140000584072	Spray arm, lower, dark grey,459mm	1	1
139A	1118949526	Upper spray arm, dark grey	1	1
140	1170481731	Container cup, small	1	1
145	140000740021	Manifold, inner, dark grey	1	1
155	140000494413	Water sump, assembly, air trap	1	1
155A	140000536015	Flap, valve, water sump, D=23,2mm	1	1
155B	1119177010	Screen, sump	1	1
260A	8078689026	Clamp, circulation pump, flow control regulator	1	1
260C	8078689034	Clamp, circulation pump, sump, 44.4mm/3.2mm	1	1
260J	8078689018	Clamp, drain hose, 30mm/2.8mm	1	1
303	NPA	Basement	1	1
320	1526272214	Grill, vapour outlet, dark grey	1	1
520	8072019014	Flange, discharge hose, D20mm	1	1

MODEL: DSF6106W and DSF6106X

CONTROL PANEL

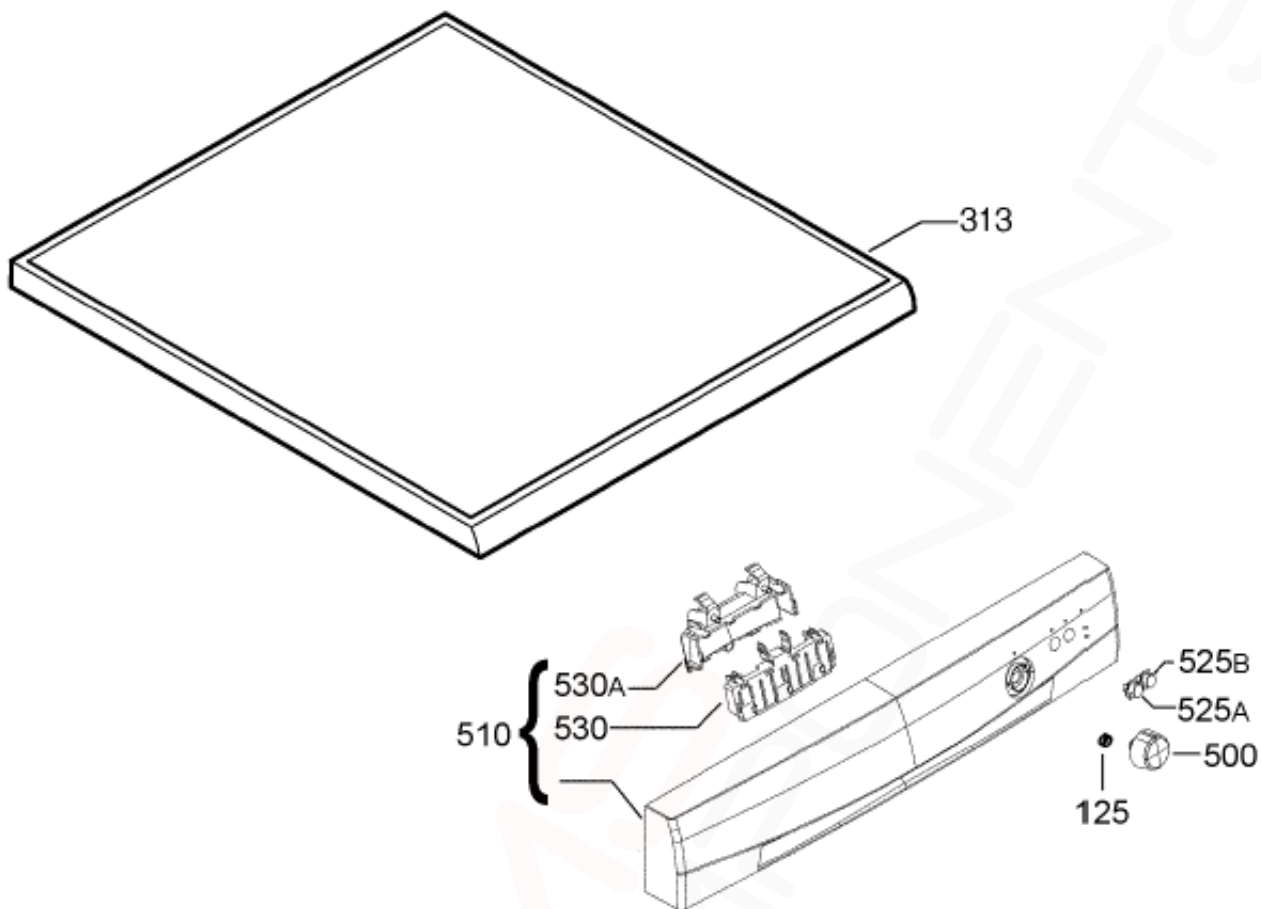

ITEM	PART No.	DESCRIPTION	QTY 6106W	QTY 6106X
125	1520227016	Knob spring	1	1
313	1561348010	Work top, white, 60	1	
313	1561348218	Work top, assembly, inox,		1
500	140002446015	Knob, white	1	
500	140002446023	Knob, inox		1
510	8086161273	Control panel, white, Dishlex, DSF6106W	1	
510	8086161281	Control panel, inox, Dishlex, DSF6106X		1
525A	140002461014	Push button, left, white	1	
525A	140002461022	Push button, left, inox		1
525B	140002462012	Push button, right, white	1	
525B	140002462020	Push button, right, inox		1
530	140002463010	Handle, white	1	
530	140002463069	Handle, Grey		1
530A	140002464018	Handle, Cover, white	1	
530A	140002464067	Handle, Cover, grey		1

MODEL: DSF6106W and DSF6106X

BASKET ASSEMBLY

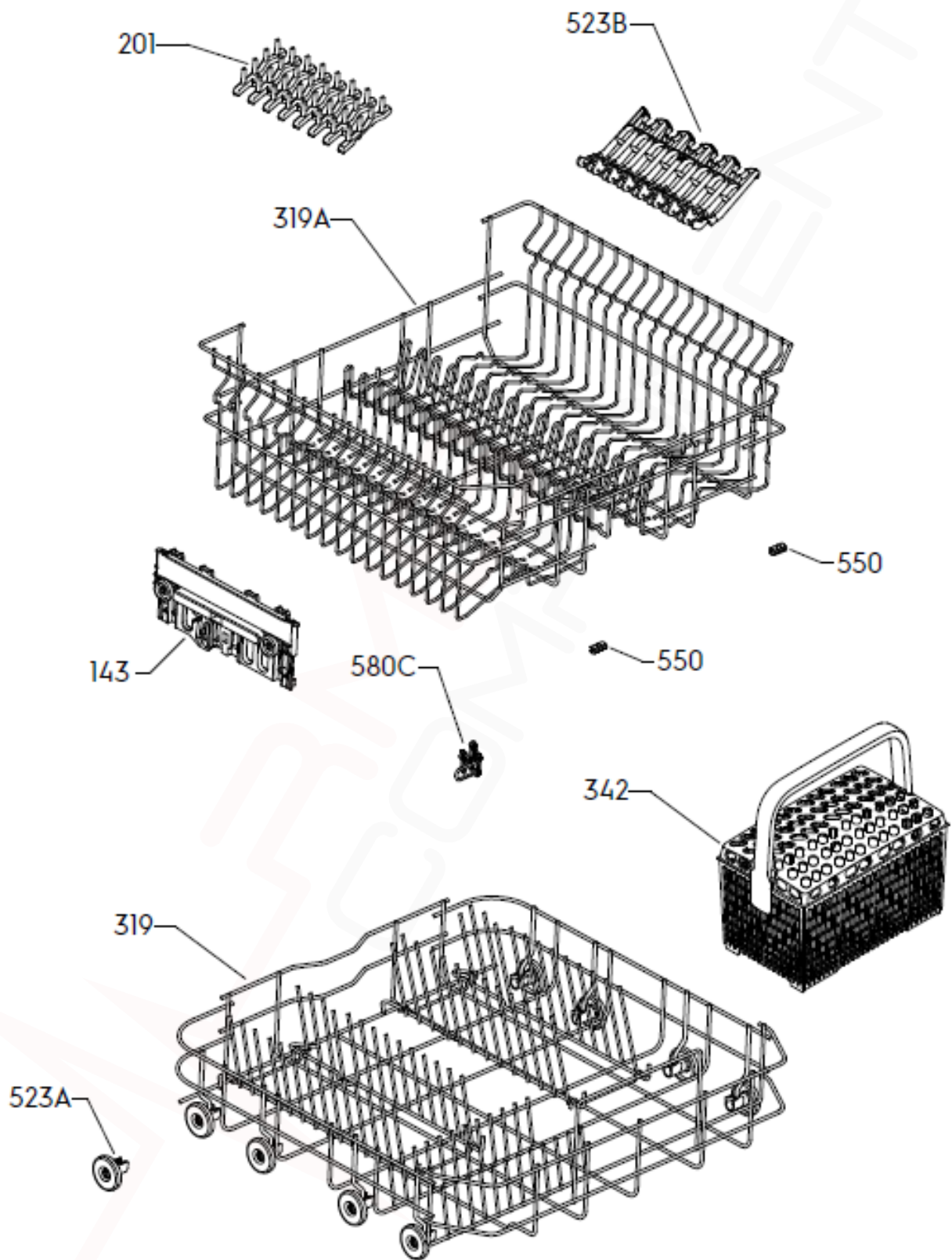

ITEM	PART No.	DESCRIPTION	QTY 6106W	QTY 6106X
143	4055364402	Adjustment, dishwasher basket, Kit	1	1
201	1380184109	Spikes,rubber,greys,8x4/175x75,3mm	1	1
319	8090030076	Dishwasher basket, bottom, greys,524x515mm	1	1
319A	140000152037	Dishwasher basket, upper, silver,517x467mm	1	1
342	1525593222	Cutlery basket, dark grey	1	1
523A	50286965004	Wheel kit, 8 pcs., dark grey, DIVA45/60 D=40mm	1	1
523B	140001199052	Support, cup, dark grey	1	1
550	4055362000	Rubber buffer, dishwasher basket, 10 pcs.	1	1
580C	140018976013	Hook, upper basket, dispenser	1	1

ABBREVIATION	MEANING
BASE BOARD	Main electronic board
CAPACITOR	Capacitor
DISPENSER	Detergent dispenser
DOOR LOCK	Door lock
DRAIN PUMP	Drain pump
HEATER	Heating element
INLET VALVE	Inlet Valve
INPUT BOARD	User interface (display)
LEAKAGE SWITCH	Anti-flooding device
MAIN SWITCH	Main switch
NTC/TURB. SENSOR	Turbidity sensor
POWER CORD	Power supply
PRESSURE SENSOR	Pressure Sensor
REG. VALVE	Regeneration valve
RINSE AID	Resin conditioning water switch
SALT AID	Salt
WASH PUMP	Washing pump
GN/YE	Green/yellow
RD	Red
BU	Blue
BR	Brown
BK	Black
TACHO	Tachometric generator