

DISHLEX

***DOMESTIC HOUSEHOLD
DISHWASHERS***

CONTENTS	PAGE N°
CABINET and BASE ASSEMBLY	2 & 3
DOOR ASSEMBLY	4 & 5
ELECTRICAL COMPONENTS	6 & 7
PUMP, SUMP and HYDRAULIC SYSTEM	8 & 9
CONTROL PANEL and WORK TOP ASSEMBLY	10 & 11
BASKET ASSEMBLY	12 & 13
AFTER MARKET ACCESSORIES	14
WIRING DIAGRAM, LEGEND & CIRCUIT DIAGRAM	15 - 17

NOTE: In Parts Listings

N.I. = Not Illustrated
N.P.A. = No Part Available
N.P.N. = Not Used on this Model

MODEL:**DSF6105W****PNC:****911519181 01**

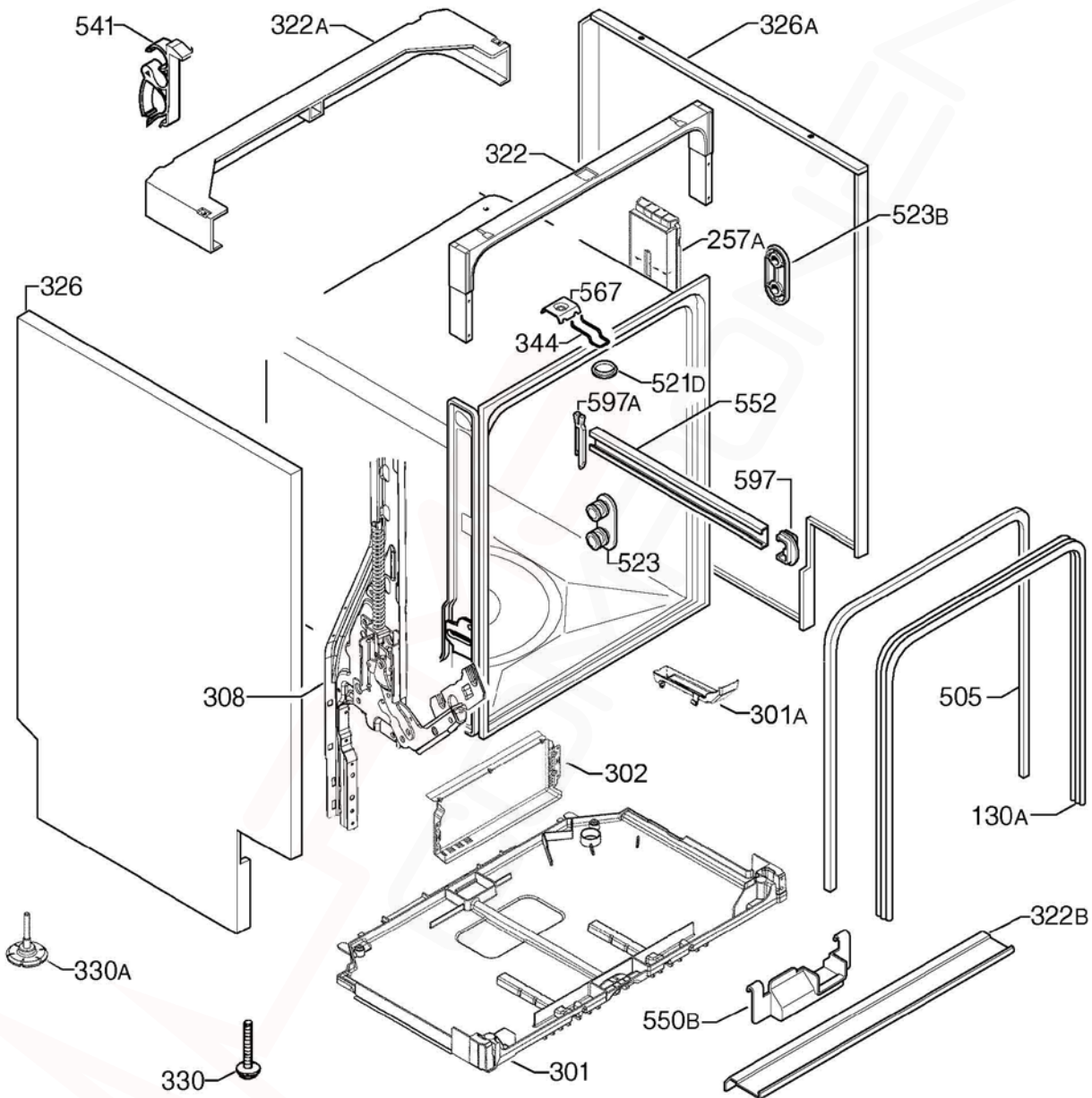

ITEM	PART N	DESCRIPTION	Ex. P09113178362	QTY
130A	1171265026	GASKET DOOR 17300mm		1
257A	N.P.A.	COUNTERWEIGHT SIDE DISHWASHER		1
301	140000527014	TRAY BOTTOM SPILLAGE		1
301A	4055250858	KIT OVERFLOW HOSE		1
302	140000750012	COVER ELEC CONTROL BOX		1
308	4055161352	KIT HINGE DOOR LH/RH		1
322	1560799114	BRACE FRONT UPPER		1
322A	1170350043	BRACE CROSSBAR UPPER REAR		1
322B	140000212039	BRACE CROSSBAR FRONT LOWER		1
326	1170153421	PANEL SIDE LEFT - WHITE		1
326A	1170153520	PANEL SIDE RIGHT - WHITE		1
330	1520664-10/1	LEG ADJUSTABLE x 36mm LONG		2
330A	8075188014	FOOT ADJUSTABLE x 48mm		2
344	1522344-05/8	LATCH DOOR LOCK		1
505	1526715410	TRIM TUB BLACK		1
521D	1526576101	COVER LATCH HOLE		1
523	50299970009	SUPPORT ROLLER KIT (PKT 4)		1
523B	1118814-00/1	BRACKET STIFFENING		4
541	N.P.A.	CLAMP HOSE		-
550B	1522345071	COVER WIRING PROTECTION		1
552	140003656026	RAIL BASKET UPPER		2
567	1523236-03/0	NUT SPEED CLIP		1
597	1520479419	STOP BASKET UPPER FRONT D/GREY		2
597A	6461234061	STOP BASKET UPPER REAR D/GREY		2

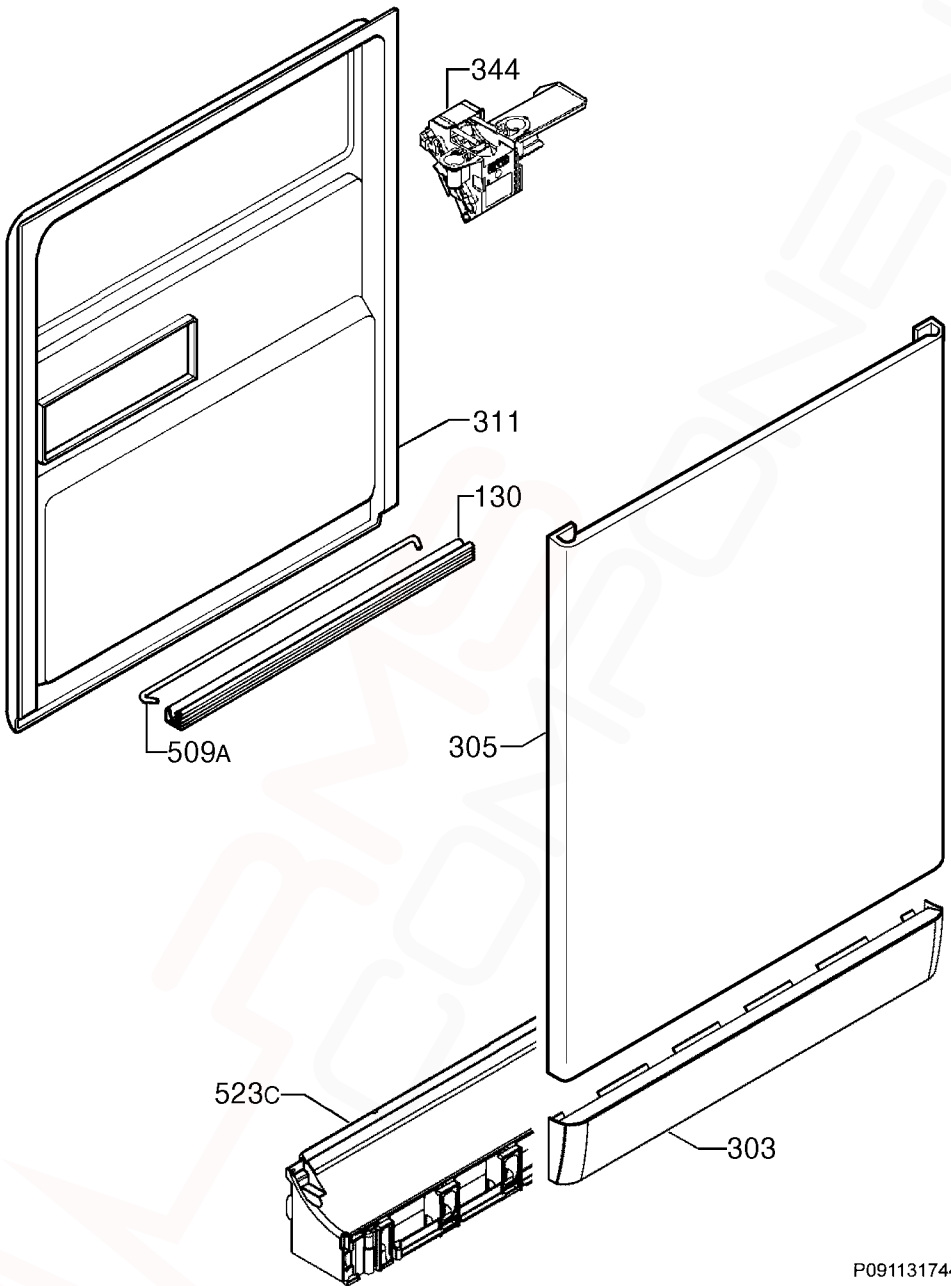

ITEM	PART N	DESCRIPTION	Ex. P09113174465	QTY
130	1527401-00/2	GASKET DOOR LOWER BLK x 550mm		1
303	8070407039	PLINTH WHITE		1
305	1561221464	PANEL OUTER DOOR - WHITE		1
311	140025959028	PANEL DOOR INNER		1
344	1113150120	LATCH DOOR LOCK		1
509A	1520419-14/2	TIE HINGE		1
523C	1170156-03/6	HOLDER PLINTH		1

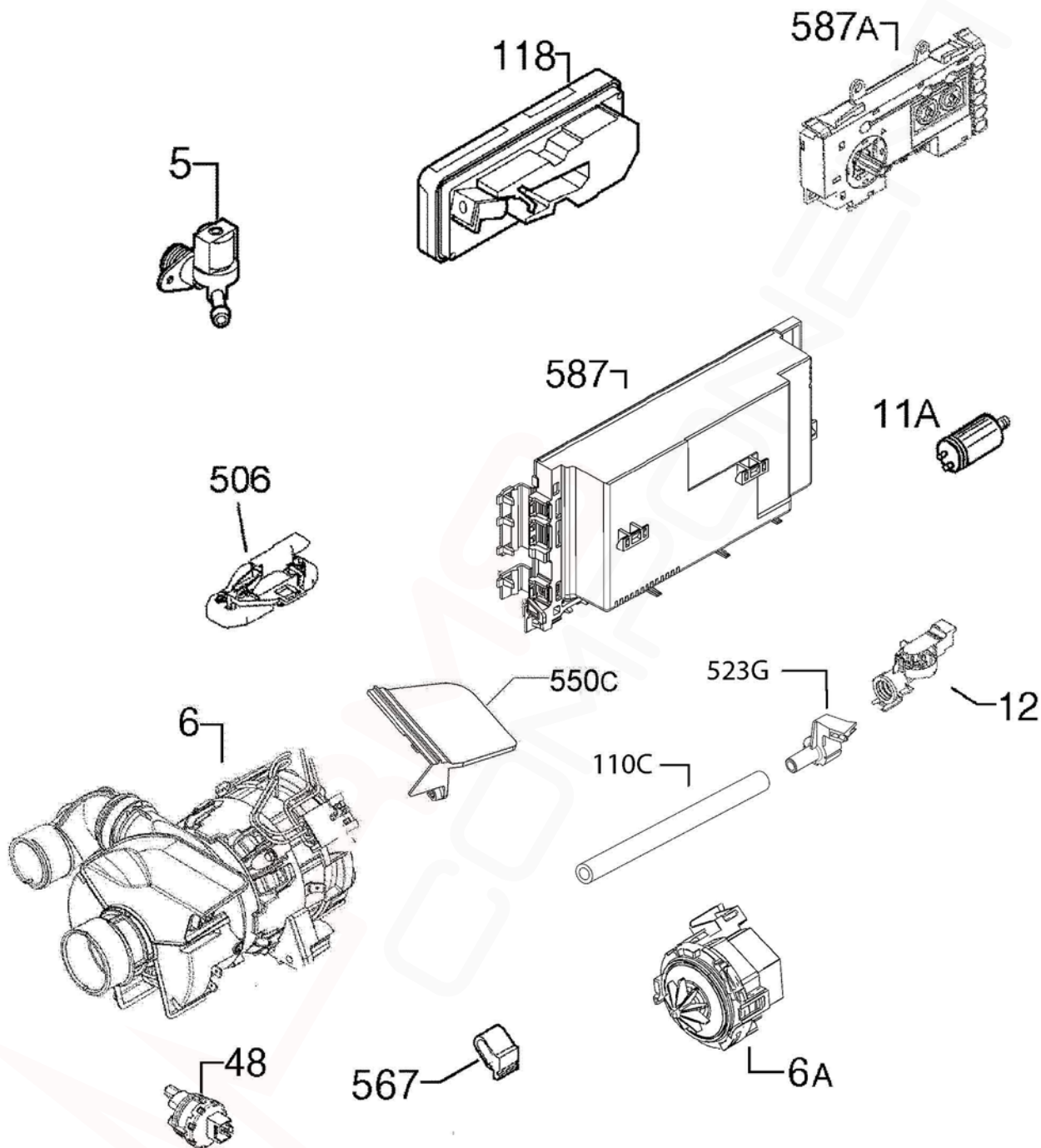

ITEM	PART N	DESCRIPTION	Ex. P09113192410	QTY
5	140001158017	VALVE FILL 2.5L/MIN		1
6	140002106056	PUMP RE-CIRC/HEATER COMP 1800W		1
6A	140000443030	PUMP DRAIN 50HZ.		1
11A	1115927012	CAPAC 3µf MOTOR DISHWASHER		1
12	140000554067	SWITCH PRESSURE SENSOR		1
48	140000401012	SENSOR TEMPERATURE TURBIDITY		1
110C	1174356111	HOSE SUMP PRESS SENSOR x 212mm		1
118	1113330128	DISPENSER DETERGENT		1
506	140000565048	SWITCH & FLOAT ASSY		1
523G	140026130017	ADAPTOR SWITCH PRESSURE SENSOR		1
550C	8080890018	COVER MOTOR DRIP PREVENTION		1
567	1171934019	SUPPORT BRACKET MOTOR RUBBER		1
587	973911519181029	PCB CONFIG ELECTRONIC PB300		1
587A	140000423487	PCB USER I/FACE AMBER EDW500		1
N.I.	140001945033	CORD SERVICE AU 2.15M		1
N.I.	8074849012	HARNESS PCB HEATER		1
N.I.	8088212090	HARNESS PCB PUMP		1
N.I.	8088471050	HARNESS PCB DOOR		1

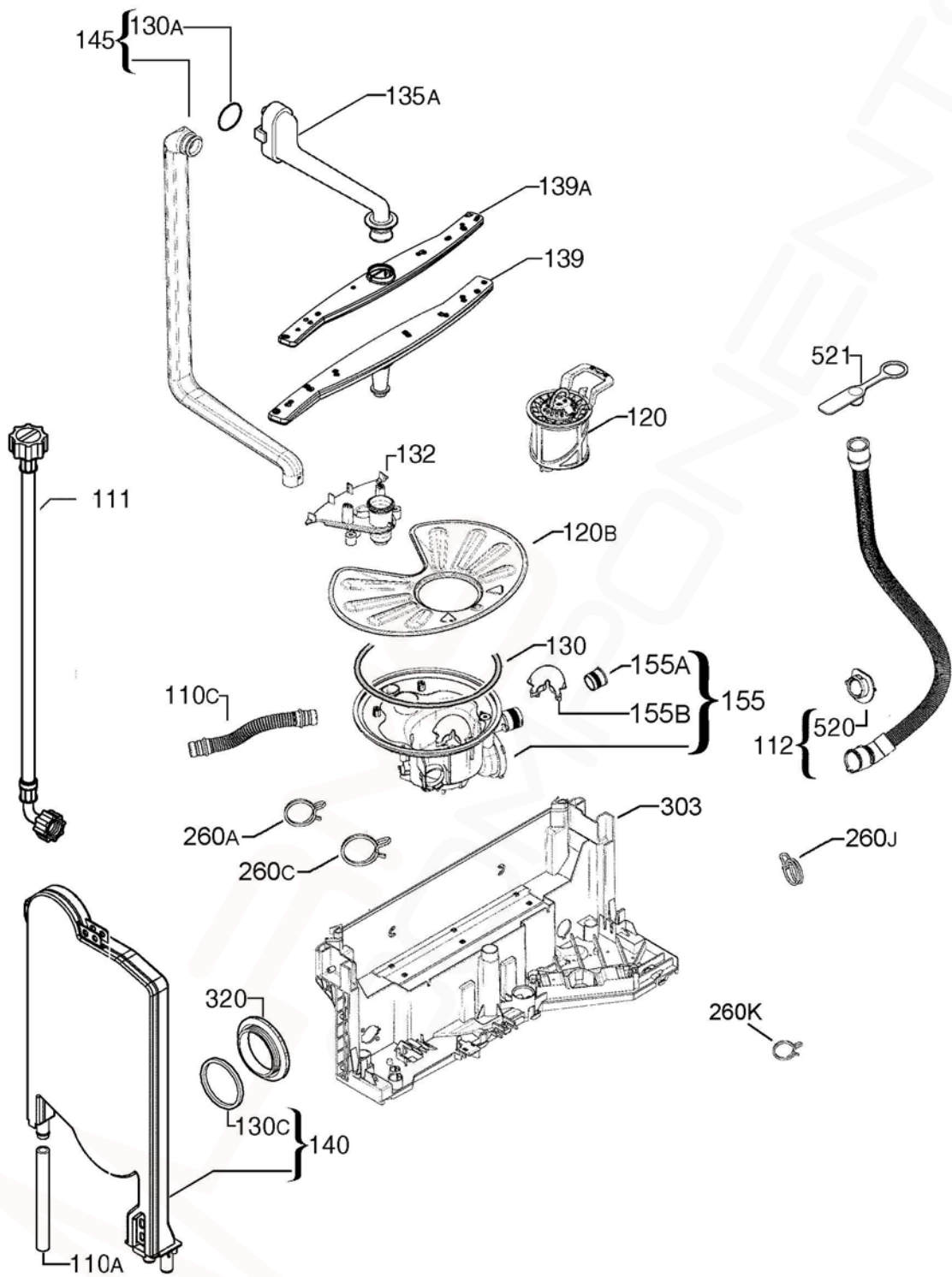

ITEM	PART N	DESCRIPTION	Ex. P09113192419	QTY
110A	1526815-10/3	TUBE AIR CHAMBER		1
110C	14000059034	HOSE SUMP TO WATERSOFT x 370mm		1
111	140000234030	HOSE FEEDER x 1500 LONG		1
112	140010997017	HOSE DRAIN x 2230mm		1
120	1561732007	FILTER DRAIN GREY ASSEMBLY		1
120B	1119209045	FILTER FLAT		1
130	1119186003	O RING SUMP		1
130A	1523119-01/2	SEAL CHANNEL DRAINAGE		1
130C	N.P.A.	SEAL AIR CHAMBER		-
132	1119158176	SUPPORT SPRAY ARM LWR DRK GREY		1
135A	1561425370	CHANNEL FEED UPPER SPRAY ARM		1
139	140000584072	SPRAY ARM LOWER DARK GREY		1
139A	1118949526	SPRAY ARM UPPER DARK GREY		1
140	1170481731	CONTAINER CUP SMALL		1
145	140000740021	TUBE MANIFOLD INNER DARK GREY		1
155	140000494215	SUMP WATER ASSEMBLY		1
155A	140000536015	VALVE NON-RETURN FLAP SUMP		1
155B	1119177010	TRAP SUMP PUMP DRAIN		1
260A	8078689026	CLAMP CIRC PUMP FLOW REGULATOR		1
260C	8078689034	CLAMP CIRCULATION PUMP-SUMP		1
260J	8078689018	CLAMP DRAIN HOSE Ø30MM		1
260K	8078689042	CLAMP Ø16mm		1
303	140000531032	BASEMENT		1
320	1526272214	VENT VAPOUR OUTLET		1
520	N.P.A.	PLUG DRAIN HOSE		-
521	N.P.A.	PLUG DRAIN HOSE		-

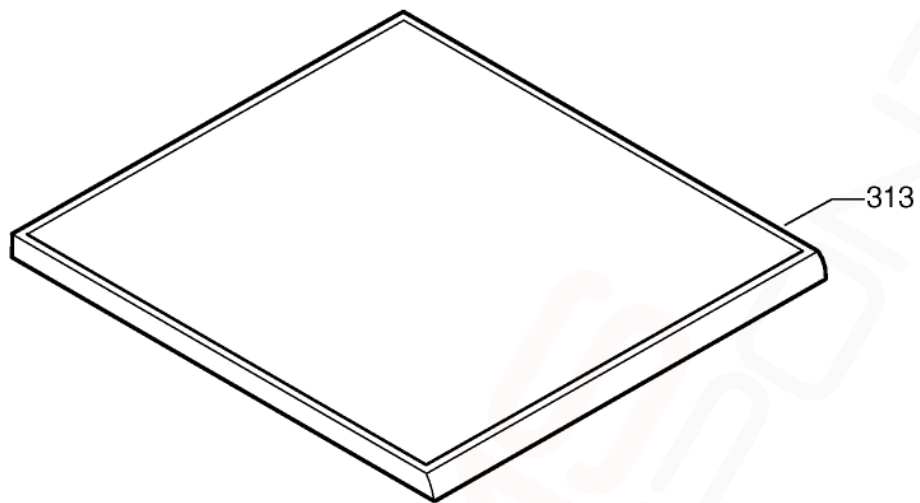

P09113176040

ITEM	PART N°	DESCRIPTION	Ex. P09113176040	QTY
125	1520227016	SPRING KNOB		1
313	1561348010	WORKTOP - WHITE		1
500	140002446015	KNOB WHITE		1
510	8086161182	PANEL CONTROL – WHITE DSF6105W		1
525A	140002461014	BUTTON PUSH LEFT - WHITE		1
525B	140002462012	BUTTON PUSH RIGHT - WHITE		1
530	140002463010	HANDLE WHITE		1
530A	140002464018	COVER HANDLE - WHITE		1
N.I.	5190530112	SCREW SWITCH HOUSING		1

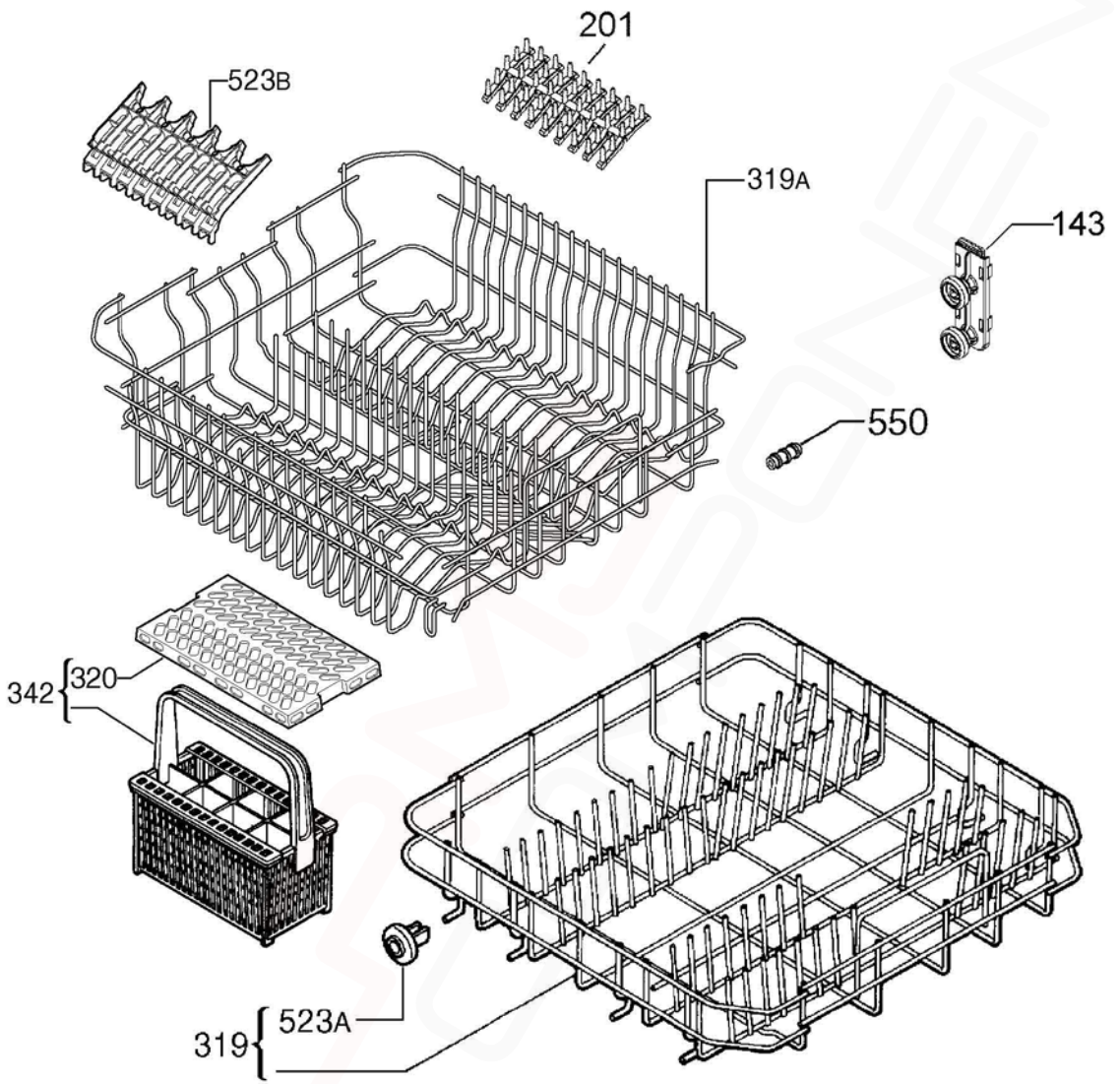

ITEM	PART N	DESCRIPTION	Ex. P09113183463	QTY
143	1561285113	ROLLER BASKET ADJUSTMENT FRNT		2
	1561285121	ROLLER BASKET ADJUSTMENT REAR		2
201	ACC088	SUPPORT SPIKES RUBBER - GREY		2
319	1561446293	BASKET LOWER DISHWASH ASSY		1
319A	140000152037	BASKET UPPER DISHWASH ASSY		1
320	N.P.A.	GRATING BASKET ASSY CUTLERY GREY		-
342	ACC107	BASKET ASSY CUTLERY GREY (Incl. Item 320)		1
523A	50286965-00/4	ROLLER KIT LOWER (PKT 8)		1
523B	140001199086	SUPPORT CUP GREY		2
550	8070264018	BUFFER DISHWASHER UPPER BSKT		2
N.I.	1561218031	HOOK BASKET UPPER DISPENSER		1

DISHWASHER ACCESSORY COMPONENTS



ITEM	PART N°	DESCRIPTION
1	ACC017	Scalex Plus Descaler Sachet 75gm
2	ACC100	Detergent Dishwasher 1kg
3	ACC102	Rinse Aid Additive 500mls
4	ACC103	Descaler Powder 350g (Dangerous Goods rules apply, min order Qty of 12)
5	ACC002	Dishwasher Salt 1kg Pack
6	ACC088	Support Spikes Rubber – Grey

P0000300001692	
BASE BOARD	Main electronic board
BOF/BH	Indication of operation
HEATER	Heating element
MAIN SWITCH	Main switch
POWER CORD	Power supply
REG. VALVE	Regeneration valve
WASH PUMP	Washing pump
RD	Red
BU	Blue
BR	Brown
BK	Black
GN/YE	Green/yellow
SALT AID	Salt
INLET VALVE	Inlet valve
DRAIN PUMP	Drain pump
DOOR LOCK	Door lock
RINSE AID	Resin conditioning water switch
PRESSURE SENSOR	Pressure Sensor
NTC/TURB. SENSOR	Turbidity sensor
LEAKAGE SWITCH	Anti-flooding device
FLOW CONTROL	Flow meter
DISPENSER	Detergent dispenser
INPUT BOARD	User interface (display)
CAPACITOR	Capacitor