

Service Manual

Microwave Oven

Simplified

NN-SD686S
NN-ST676M
NN-ST666W
NN-ST656W

QPQ(Australia & New Zealand)



Please file and use this manual together with the service manual for Model NN-S560WF (ORDER NO. SIMMC0006012C3)

Specifications:

Specifications:	Models:	SD686S	ST676M	ST666W	ST656W
Power Source:	230V-240V AC Single Phase, 50Hz				
Power Requirement:	1120W				
Output:	1100W				
Microwave Frequency:	2450MHz				
Timer:	90 min. 00 sec.		99 min. 99 sec.		
Outside Dimensions:	518mm(W) X 404mm(D) X 301mm(H)				
Oven Cavity Dimensions:	375mm(W) X 386mm(D) X 225mm(H)				
Weight:	12.0 kg				
PbF	This product with PbF				
Specifications subject to change without notice.					

Panasonic®

© 2006 Panasonic Home Appliances Microwave Oven (Shanghai) Co., Ltd. All rights reserved. Unauthorized copying and distribution is a violation of law.

4 EXPLODED VIEW AND PARTS LIST

4.1. EXPLODED VIEW

EXPLODED VIEW

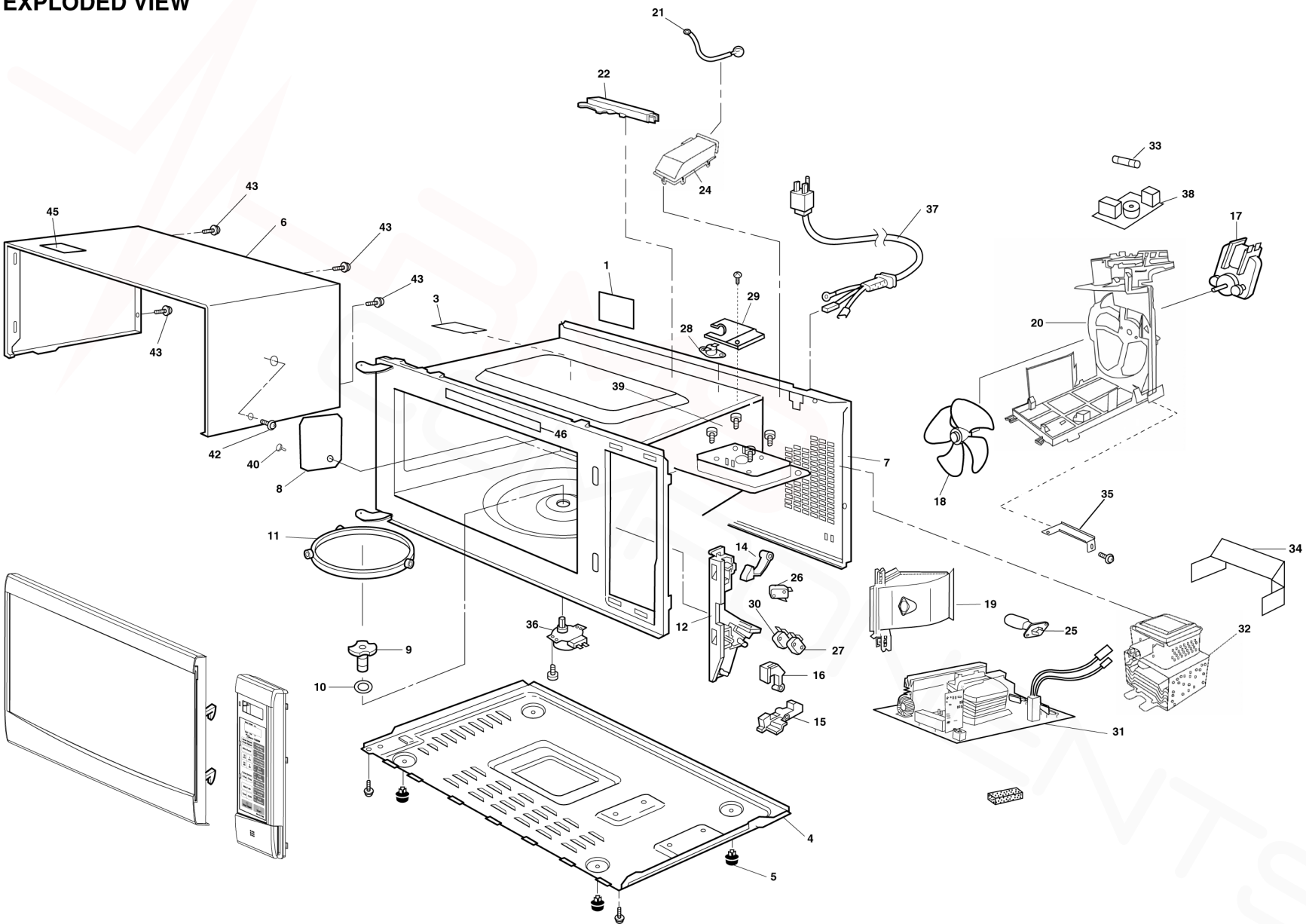

4.2. PARTS LIST

NOTE:

1. When ordering replacement part(s), please use part number(s) shown in this part list.

Do not use description of the part.

2. Important safety notice:

Components identified by mark have special characteristics important for safety.

When replacing any of these components, use only manufacture's specified parts.

NOTE:

"A" parts are supplied by CSD (Japan)

"F" parts are supplied by PHAMOS (China)

Ref. No.	Part No.	Part Name & Description	Pcs/Set	Remarks
1	F00066V00HP	CAUTION LABEL	1	
3	F21555500AP	OVEN STICKY PAPER	1	
4	F10014T00APG	BASE	1	
5	F10084T00AP	RUBBER FOOT	4	
6	F110D5Y00SAP	CABINET BODY (U)	1	SD686S
6	F110D5Y60SAP	CABINET BODY (U)	1	ST676M
6	F110D5Y30HAP	CABINET BODY (U)	1	ST666W, ST656W
7	△ F200A8F00AP	OVEN (U)	1	SD686S, ST676M, ST666W
7	△ F200A8F40AP	OVEN (U)	1	ST656W
8	F20555L00AP	COVER	1	
9	F21315Y00AP	PULLY SHAFT	1	
10	F2177-F80	WASHER	1	
11	F290D9330AP	ROLLER RING (U)	1	
12	△ F30206G30AP	DOOR HOOK	1	
14	F31366G30AP	HOOK LEVER A	1	
15	F31376G30AP	HOOK LEVER B	1	
16	F31386G30AP	HOOK LEVER C	1	
17	F400A6V00QP	FAN MOTOR	1	AC240V, SINGLE PHASE, 50Hz
18	F40084T00AP	FAN BLADE	1	
19	F40257D00APG	AIR GUIDE A	1	
20	F41444T00AP	ORIFICE	1	
21	A707S4T00AP	STEAM SENSOR	1	SD686S, ST676M, ST666W
22	F64508660AP	SENSOR COVER B	1	SD686S, ST676M, ST666W
24	F65434T00AP	SENSOR COVER C	1	SD686S, ST676M, ST666W
25	F612E8H00XP	INCANDESCENT LAMP (U)	1	
26	△ J61415G10XN	MICRO SWITCH	1	(PRIMARY LATCH SWITCH) (V-15G-3C25)
27	△ J61414T00AP	MICRO SWITCH	1	(SECONDARY LATCH SWITCH) (D3V-16G-3C25)
28	△ F61455L00CP	THERMAL CUTOUT	1	105°C
29	F66264T00CP	THERMAL CUTOUT INSULATION BRACKET	1	
30	△ F61785U30XN	MICRO SWITCH	1	(SHORT SWITCH) (D3V-1G-2C25)
31	△ F606Y4V00XN	H.V. INVERTER (U)	1	
32	△ 2M261-M32J3Y	MAGNETRON	1	
33	△ F62306V60BP	FUSE	1	10A/240V, 50Hz
34	F40264T60APG	AIR GUIDE B	1	
35	F61844T00AP	GROUNDING PLATE	1	
36	F63265U30XN	TURNTABLE MOTOR	1	
37	△ F900C9660QP	AC CORD W/PLUG	1	
38	F692Y8A00QP	NOISE FILTER (U)	1	
39	XTWFA4+12T	SCREW	4	FOR MAGNETRON
40	XTTFA4+6BN	SCREW	1	FOR COVER
42	XTCAFA4+12AFM	SCREW	1	FOR CABINET BODY SIDE (SD686S)
42	XTCAFA4+12AFS	SCREW	1	FOR CABINET BODY SIDE (ST676M)
42	XTCAFA4+12AFW	SCREW	1	FOR CABINET BODY SIDE (ST666W, ST656W)
43	XTWFA4+12D	SCREW	4	FOR CABINET BODY
45	F02445Y00AP	CAUTION LABEL	1	SD686S
46	F03348F60QP	MENU LABEL	1	SD686S

4.3. DOOR ASSEMBLY

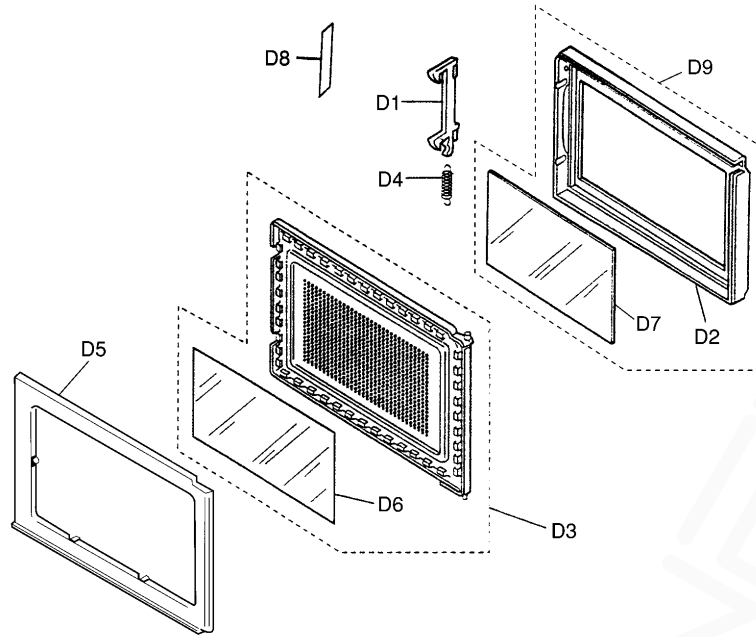

Ref. No.	Part No.	Part Name & Description	Pcs/Set	Remarks
D1	F3018-1200	DOOR KEY A	1	
D2	△ F301A8F70SQP	DOOR A	1	ST676M
D2	△ F301A8F70HQP	DOOR A	1	ST666W, ST656W
D3	△ F302K5L00AP	DOOR E (U)	1	
D4	F30215G10XN	DOOR KEY SPRING	1	
D5	△ F30854T00AP	DOOR C	1	
D6	△ F31456V60XP	DOOR SCREEN A	1	
D7	F31468F70BQP	DOOR SCREEN B	1	ST676M, ST666W, ST656W
D8	F01726V00JP	CAUTION LABEL B	1	
D9	△ F301A8F60SQP	DOOR A (U)	1	SD686S

4.4. WIRING MATERIALS

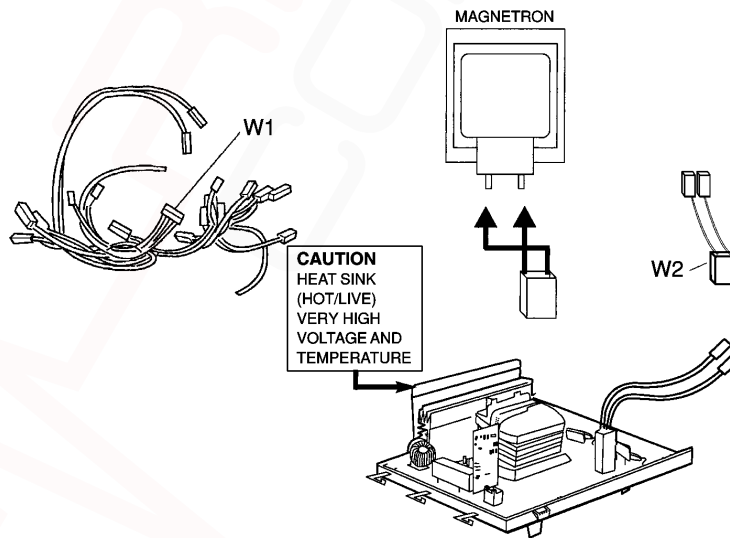

Ref. No.	Part No.	Part Name & Description	Pcs/Set	Remarks
W1	F030A8A00QP	LEAD WIRE HARNESS	1	
W2	F030E8A00QP	H.V. LEAD WIRE	1	

4.5. ESCUTCHEON BASE ASSEMBLY

4.5.1. NN-SD686S

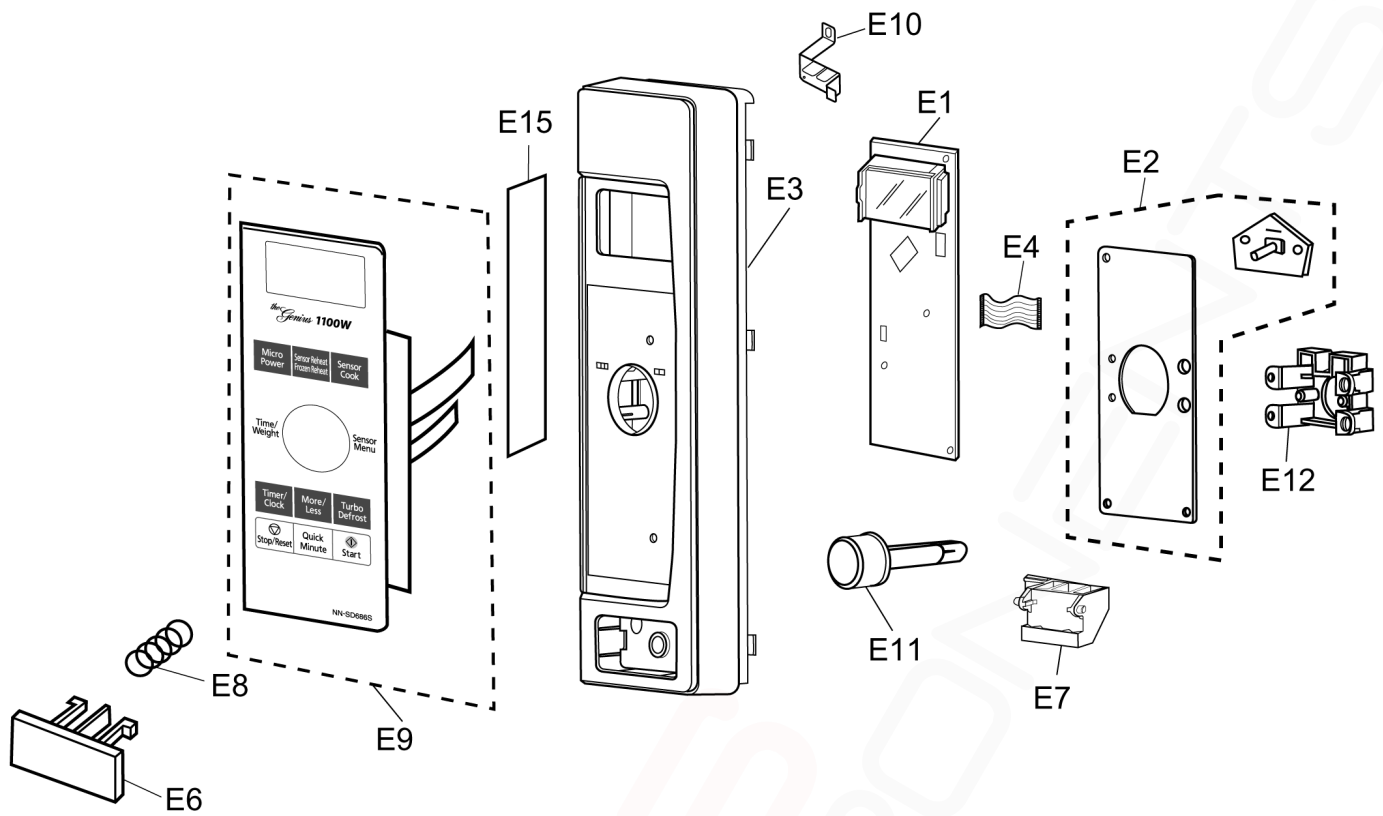

Ref. No.	Part No.	Part Name & Description	Pcs/Set	Remarks
E1	F603L8F60QP	D.P.CIRCUIT (AU)	1	SD686S
E2	F603Y8F60QP	D.P.CIRCUIT (DU)	1	SD686S
E3	F800L8F60SQP	ESCUTCHEON BASE (U)	1	SD686S
E4	F66167D00AP	FLAT CABLE	1	SD686S
E6	F80725Y00SAP	DOOR OPENING BUTTON	1	SD686S
E7	F82565Y00AP	DOOR OPENING LEVER	1	SD686S
E8	F80375K00AP	COOK BUTTON SPRING	1	
E9	F630Y8F60SQP	MEMBRANE SWITCH (U)	1	SD686S
E10	F90095X00AP	GROUNDING PANEL	1	SD686S
E11	F803G7D00BAP	POP-UP DIAL (U)	1	SD686S
E12	F80187D00BAP	BACKSTOP	1	SD686S
E15	F00078F60SQP	NAME PLATE	1	SD686S

4.5.2. NN-ST676M, ST666W, ST656W

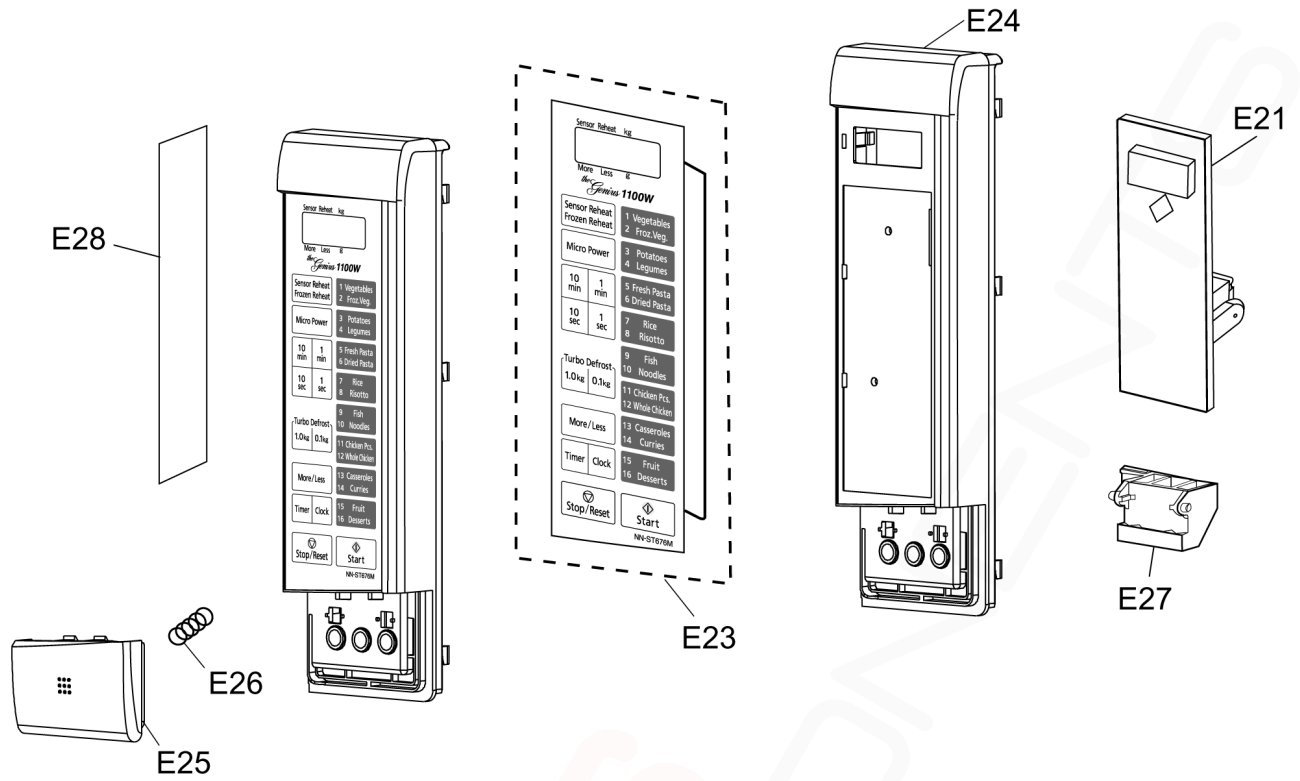

Ref. No.	Part No.	Part Name & Description	Pcs/Set	Remarks
E21	F603L8F70QP	D.P.CIRCUIT (AU)	1	ST676M
E21	F603L8F80QP	D.P.CIRCUIT (AU)	1	ST666W
E21	F603L8F90QP	D.P.CIRCUIT (AU)	1	ST656W
E23	F630Y8F70BQP	MEMBRANE SWITCH (U)	1	ST676M
E23	F630Y8F80BQP	MEMBRANE SWITCH (U)	1	ST666W
E23	F630Y8F90BQP	MEMBRANE SWITCH (U)	1	ST656W
E24	F80348F70SQP	ESCUTCHEON BASE	1	ST676M
E24	F80348F70HQP	ESCUTCHEON BASE	1	ST666W, ST656W
E25	F80728F70SQP	DOOR OPENING BUTTON	1	ST676M
E25	F80728F70HQP	DOOR OPENING BUTTON	1	ST666W, ST656W
E26	F80375K00AP	COOK BUTTON SPRING	1	
E27	F82566K10AP	DOOR OPENING LEVEL	1	ST676M, ST666W, ST656W
E28	F00078F70SQP	NAME PLATE	1	ST676M
E28	F00078F80HQP	NAME PLATE	1	ST666W
E28	F00078F90HQP	NAME PLATE	1	ST656W

4.6. PACKING AND ACCESSORIES

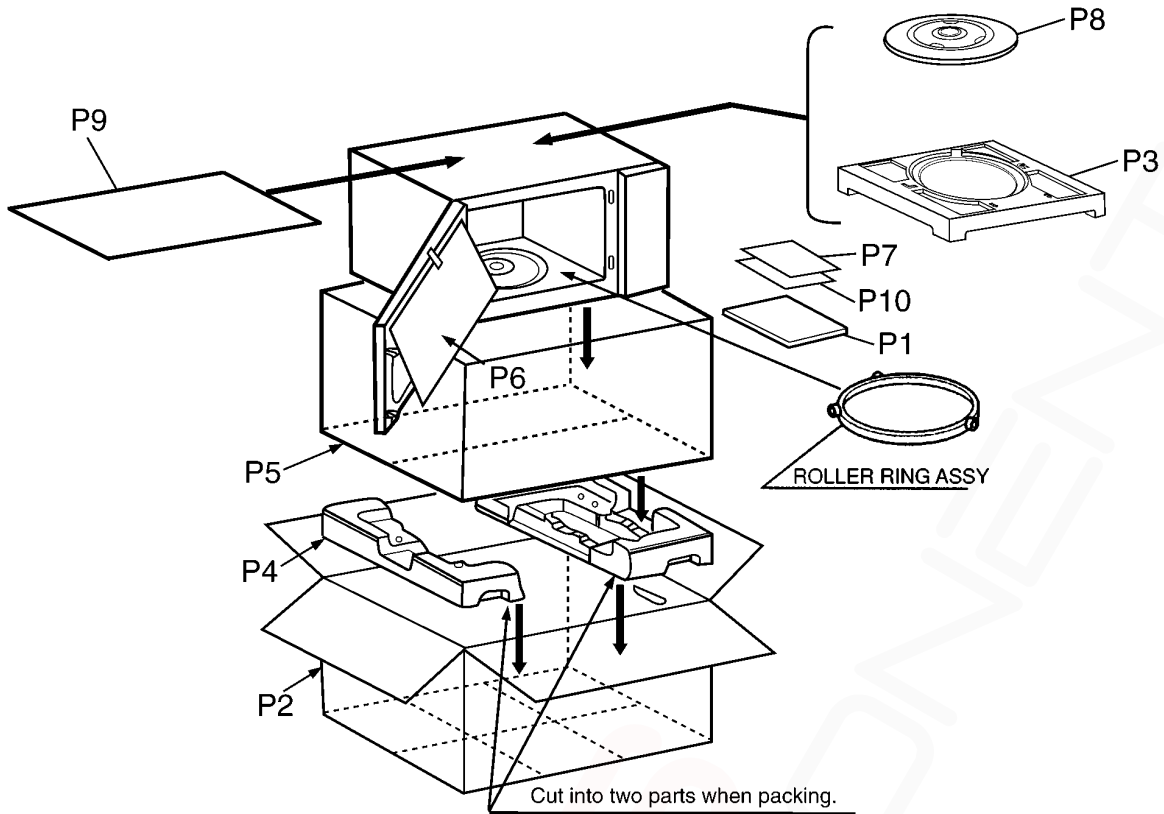

Ref. No.	Part No.	Part Name & Description	Pcs/Set	Remarks
P1	F00038F60QP	INSTRUCTION MANUAL	1	SD686S
P1	F00038F70QP	INSTRUCTION MANUAL	1	ST676M, ST666W, ST656W
P2	F01028F60SQP	PACKING CASE, PAPER	1	SD686S
P2	F01028F70SQP	PACKING CASE, PAPER	1	ST676M
P2	F01028F80HQP	PACKING CASE, PAPER	1	ST666W
P2	F01028F90HQP	PACKING CASE, PAPER	1	ST656W
P3	F01046K50AP	UPPER FILLER	1	
P4	F01055L00AP	LOWER FILLER	1	
P5	F01067F00AP	P. E. BAG	1	SD686S
P5	F01068100XN	P. E. BAG	1	ST676M, ST666W, ST656W
P6	F01078100XN	DOOR SHEET	1	
P7	F00166V20QP	NOTICE	1	SD686S
P8	F06014T00AP	COOKING TRAY	1	
P9	F01924T00AP	SHEET	1	ST676M
P10	F00065G40AP	CAUTION LABEL	1	

4.7. H.V. INVERTER BOARD MAIN PARTS LIST (F606Y4V00XN)

Ref. No.	Part No.	Part Name & Description	Pcs/Set	Remarks
Q701		TRANSISTOR SI	1	
Q702	A691E4V10GP	TRANSISTOR SI	1	
DB701	AESTRS2006M	DIODE SI	1	20A, 600V
D701, D702	A62024V00GP	DIODE SI	2	0.3A
C704, C705	ECWH30822JUA	CAPACITOR	2	8200PF 3000VDC
T701	F609A4V00XN	H.V. TRANSFORMER	1	
	F607D4V00XN	D.P.CIRCUIT (KU)	1	
L701	F50204V00XN	CHOKE COIL	1	
CT701	F66904V00XN	CURRENT TRANSFORMER	1	