

Service Manual

Microwave Oven

NN-ST785S

QPQ (Australia & New Zealand)

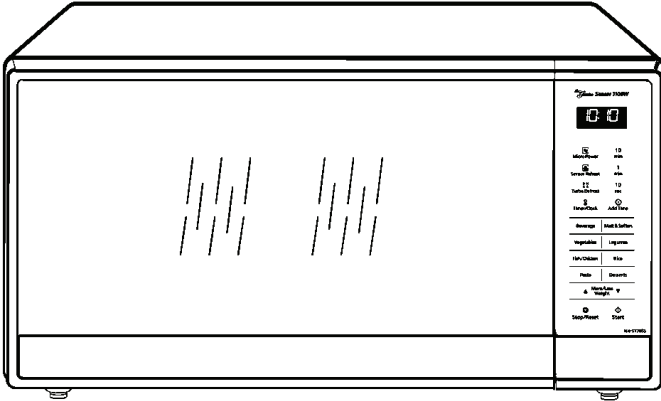

Specifications:

Specifications:	Models:	NN-ST785S
Power Source:		230V-240V AC Single Phase, 50Hz
Power Consumption:		1000W
Output:		1100W
Microwave Frequency:		2450MHz
Timer:		30 min. / Stage (P10 Power) ~ 3 Stage Maximum 99 min. 99 sec / Stage (Other Power Levels) ~ 3 Stage Maximum
Outside Dimensions:		555mm(W) X 304mm(H) X 493mm(D)
Oven Cavity Dimensions:		398mm(W) X 210mm(H) X 470mm(D)
Weight:		14.3 kg
PbF		This product with PbF
Specifications subject to change without notice.		

8 EXPLODED VIEW AND PARTS LIST

8.1. EXPLODED VIEW

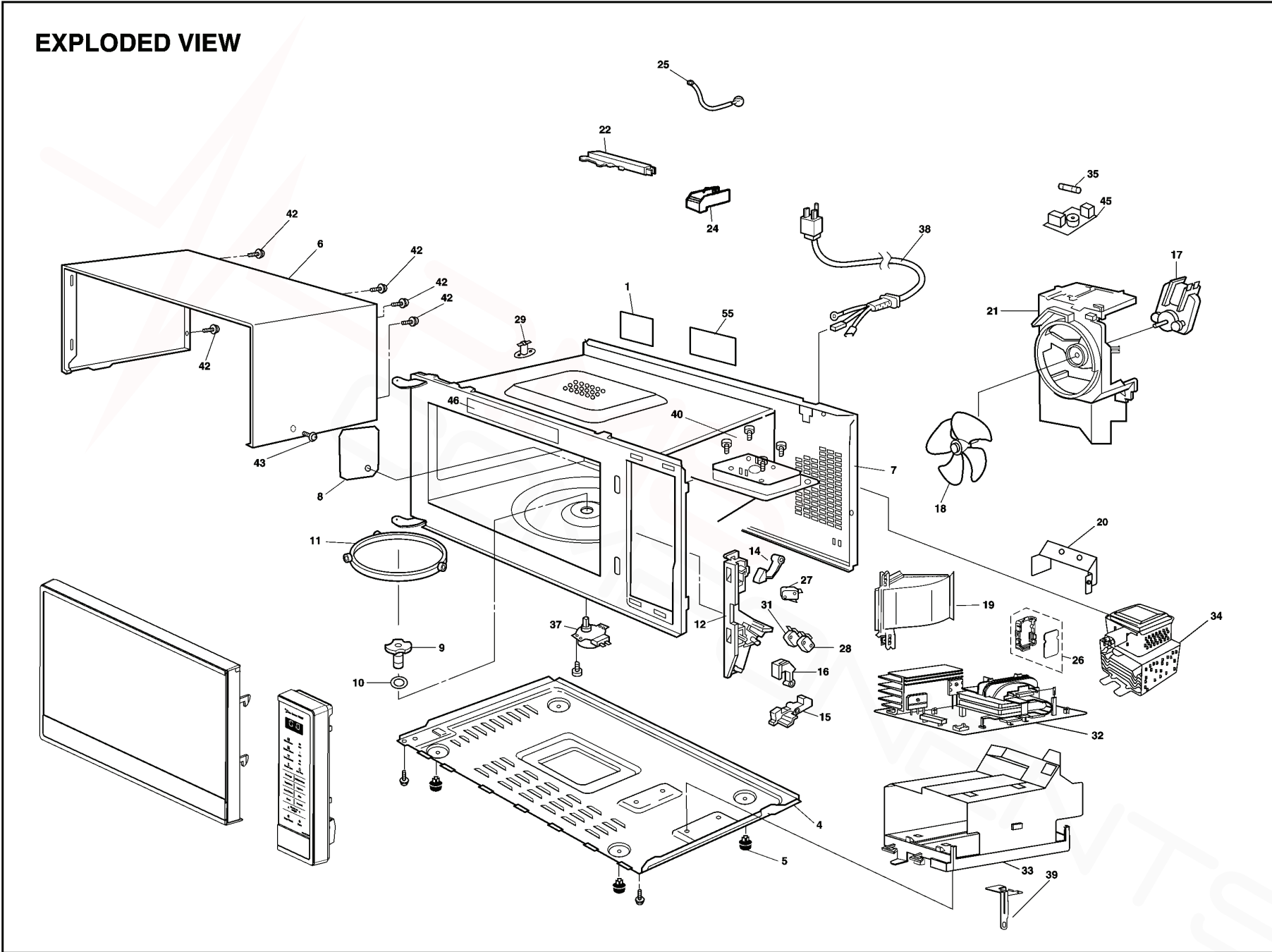

8.2. PARTS LIST

NOTE:

1. When ordering replacement part(s), please use part number(s) shown in this part list.

Do not use description of the part.

2. Important safety notice:

Components identified by mark have special characteristics important for safety.

When replacing any of these components, use only manufacture's specified parts.

Ref. No.		Part No.	Part Name & Description	Pcs/Set	Remarks
1		F00066V00HP	CAUTION LABEL	1	
4		F10016H60APG	BASE	1	
5		F10084T00APS	RUBBER FOOT	4	
6		F10095X20BCP	CABINET BODY	1	
7	△	F200ABP20HAP	OVEN (U)	1	
8		F2055BP20AP	COVER	1	
9		F2131BP20AP	PULLY SHAFT	1	
10		F2177-F80	WASHER	1	
11		F290DBP20AP	ROLLER RING (U)	1	
12	△	F30206G30AP	DOOR HOOK	1	
14		F31366G30AP	HOOK LEVER A	1	
15		F31376G30AP	HOOK LEVER B	1	
16		F31386G30AP	HOOK LEVER C	1	
17		F400A6V00QP	FAN MOTOR	1	AC240V, SINGLE PHASE, 50Hz
18		F40084T00AP	FAN BLADE	1	
19		F4025BP20AP	AIR GUIDE A	1	
20		F40264T60APG	AIR GUIDE B	1	
21		F41445W00AP	ORIFICE	1	
22		F64508660AP	SENSOR COVER B	1	
24		F65434W00AP	SENSOR COVER C	1	
25		J607S4M00AP	STEAM SENSOR	1	
26		F612EBQ00QP	LAMP (U)	1	LED LAMP INSIDE
27	△	F61425U30XN	MICRO SWITCH	1	(PRIMARY LATCH SWITCH)
28	△	F61415U30XN	MICRO SWITCH	1	(SECONDARY LATCH SWITCH)
29	△	F61455L00CP	THERMAL CUTOUT	1	105°C
31	△	F61785U30XN	MICRO SWITCH	1	(SHORT SWITCH)
32	△	F606YBA00QP	H.V. INVERTER (U)	1	
33		F65856K50AP	INVERTER BRACKET	1	
34	△	2M261-M32JP	MAGNETRON	1	
35	△	F62306V60BP	FUSE	1	10A/240V, 50Hz
37		F63269P00HP	TURNTABLE MOTOR	1	
38	△	F900C9J20QP	AC CORD W/PLUG	1	
39		F66626H60AP	GROUNDING PLATE	1	
40		XTWFL4+12T	SCREW	4	FOR MAGNETRON
42		XTWFA4+12D	SCREW	5	FOR CABINET BODY
43		XTTFA4+6BFZ	SCREW	1	FOR CABINET BODY SIDE
45		F607XBQ00QP	NOISE FILTER	1	
46		F0334BQ00QP	MENU LABEL	1	
55		F0007BQ00SQP	NAME PLATE	1	

8.3. ESCUTCHEON BASE ASSEMBLY

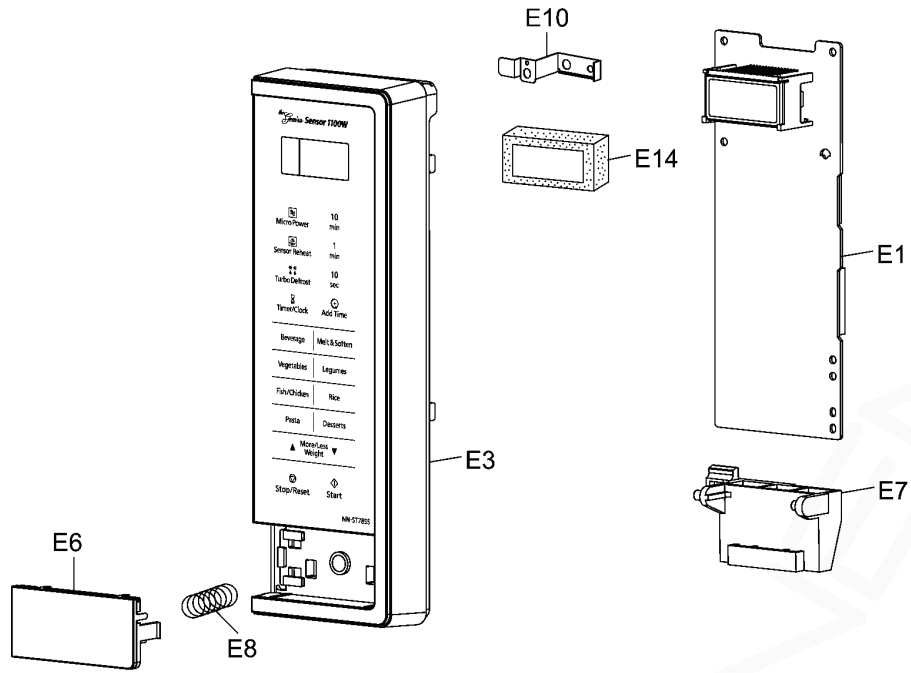

Ref. No.	Part No.	Part Name & Description	Pcs/Set	Remarks
E1	F603LBQ00QP	D. P. CIRCUIT (AU)	1	
E3	F800LBQ00SQP	ESCUTCHEON BASE (U)	1	
E6	F891PBP90SAP	DOOR OPENING BUTTON (U)	1	
E7	F82565X00AP	DOOR OPENING LEVER	1	
E8	F80375K00AP	COOK BUTTON SPRING	1	
E10	F90098N00AP	GROUNDING PANEL	1	
E14	F8284BQ00AP	CUSHION RUBBER	1	

8.4. DOOR ASSEMBLY

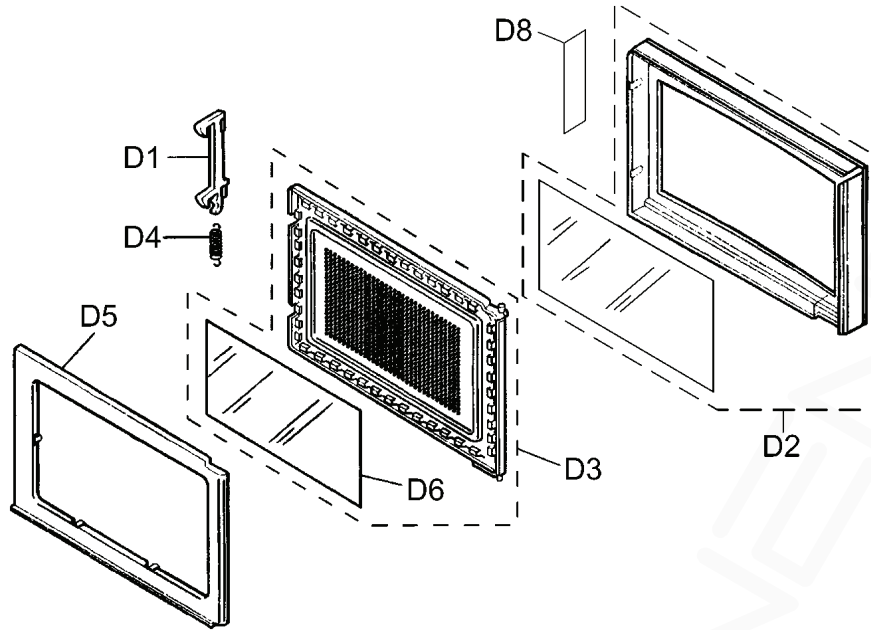

Ref. No.		Part No.	Part Name & Description	Pcs/Set	Remarks
D1		F30186P40AG	DOOR KEY A	1	
D2	△	F302ABP90SCP	DOOR A (U)	1	
D3	△	F302KBF20AP	DOOR E (U)	1	
D4		F30216P40AG	DOOR KEY SPRING	1	
D5	△	F3085BF20AP	DOOR C	1	
D6	△	F31454W00AP	DOOR SCREEN A	1	
D8		F0172BN50QP	CAUTION LABEL B	1	

8.5. WIRING MATERIALS

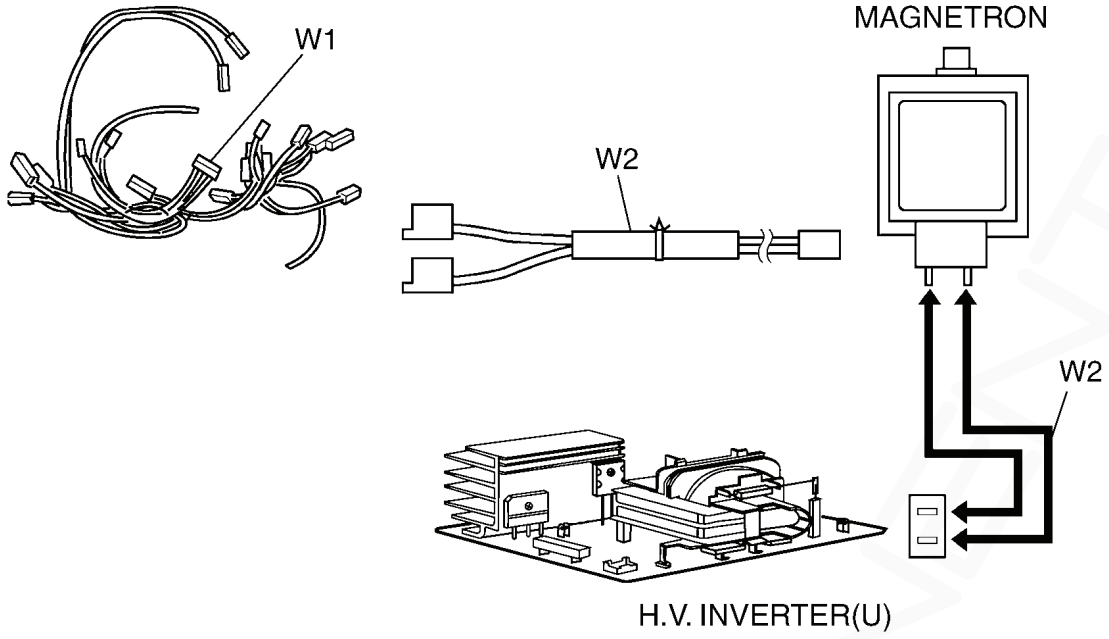

Ref. No.	Part No.	Part Name & Description	Pcs/Set	Remarks
W1	F030ABQ00QP	LEAD WIRE HARNESS	1	
W2	F030E6G30CP	H.V. LEAD WIRE	1	

8.6. PACKING AND ACCESSORIES

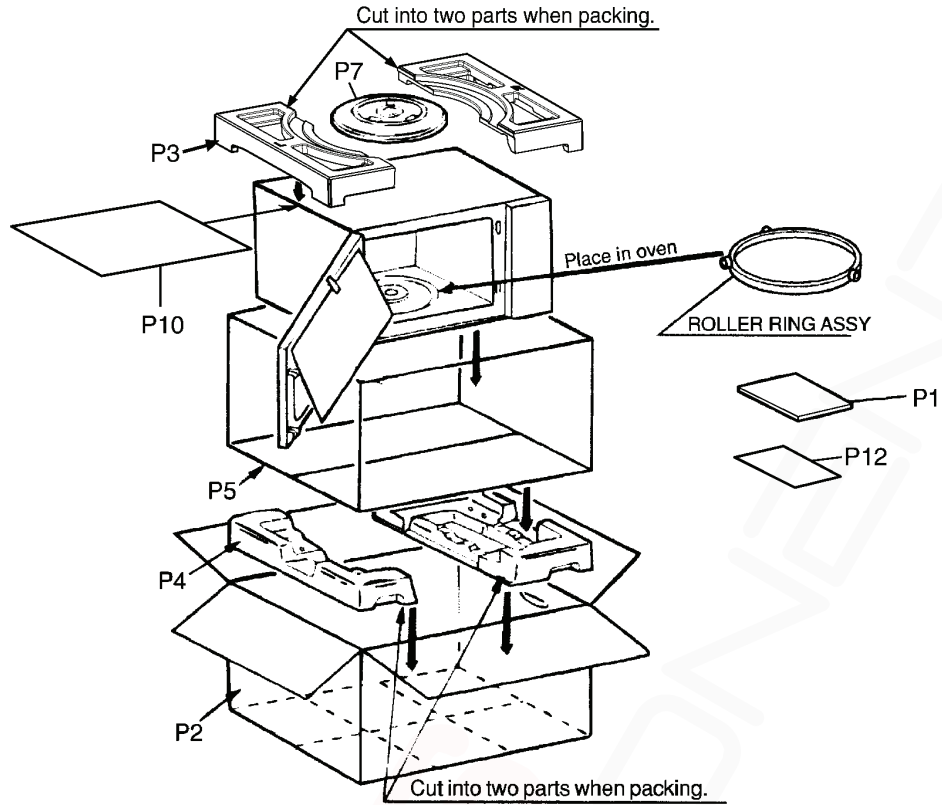

Ref. No.	Part No.	Part Name & Description	Pcs/Set	Remarks
P1	F0003BQ00QP	INSTRUCTION MANUAL	1	
P2	F0102BQ00SQP	PACKING CASE, PAPER	1	
P3	F0104BP80AP	UPPER FILLER	1	
P4	F0105BP80AP	LOWER FILLER	1	
P5	F01067C50AP	P. E. BAG	1	
P7	A06014A00AP	COOKING TRAY	1	
P10	F01924U00AP	SHEET	1	
P12	F00166V20QP	NOTICE	1	