

Service Manual

Microwave Oven

NN-ST663W

QPQ (Australia & New Zealand)

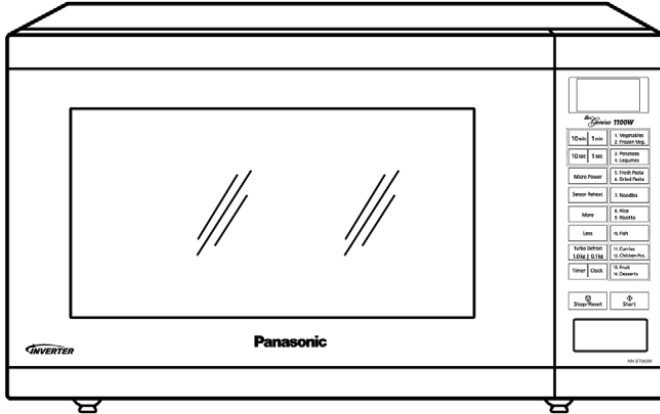

Specifications:

Specifications:	Model:	NN-ST663W
Power Source:		230V-240V AC Single Phase, 50Hz
Power Consumption:		1000W
Output:		1100W
Microwave Frequency:		2450MHz
Timer:		30 min. / Stage (HIGH Power) ~ 3 Stage Maximum 99 min. 99 sec / Stage (Other Power Levels) ~ 3 Stage Maximum
Outside Dimensions:		525mm(W) x 388mm(D) x 310mm(H)
Oven Cavity Dimensions:		355mm(W) x 365mm(D) x 251mm(H)
Net Weight:		11.5kg
PbF		This product with PbF
Specifications subject to change without notice.		

8 EXPLODED VIEW AND PARTS LIST

8.1. EXPLODED VIEW

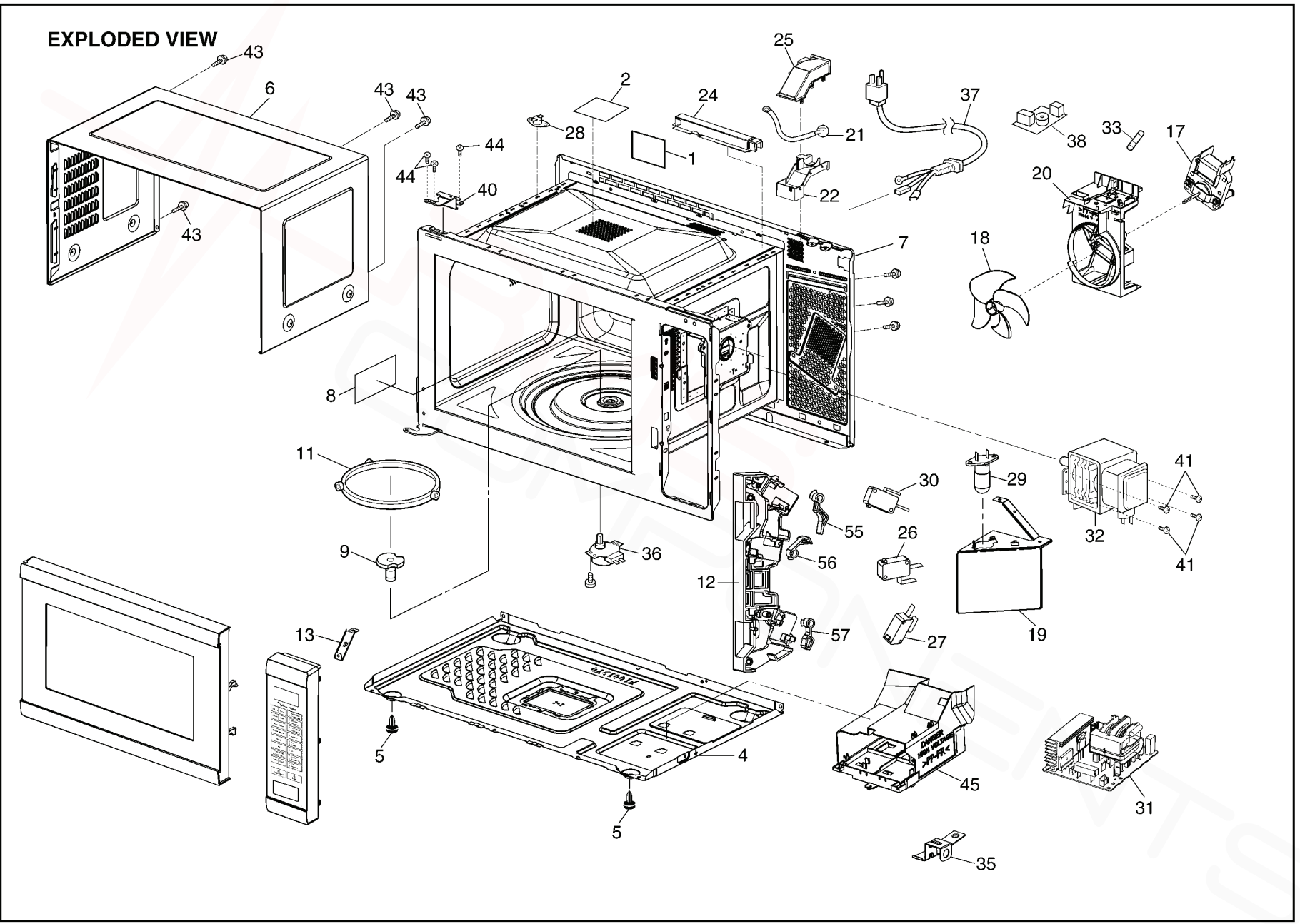

8.2. PARTS LIST

NOTE:

1. When ordering replacement part(s), please use part number(s) shown in this part list.

Do not use description of the part.

2. Important safety notice:

Components identified by \triangle mark have special characteristics important for safety.

When replacing any of these components, use only manufacture's specified parts.

Ref. No.		Part No.	Part Name & Description	Pcs/Set	Remarks
1		F00066V00HP	CAUTION LABEL	1	
2		F21559Y10QP	OVEN STICKY PAPER	1	
4		F10019Y00AP	BASE	1	
5		F10089W40HPS	RUBBER FOOT	2	
6		F10099Y00HAP	CABINET BODY (U)	1	
7	\triangle	F200A9Y00SQP	OVEN (U)	1	
8		F20559Y00AP	COVER	1	
9		F21319Y00AP	PULLY SHAFT	1	
11		F290D6W50XP	ROLLER RING (U)	1	
12	\triangle	F30209X70EP	DOOR HOOK	1	
13		F11619Y00AP	REINFORCEMENT BRACKET	1	
17		F400A9Y00QP	FAN MOTOR	1	
18		F40089Y00AP	FAN BLADE	1	
19		F40259Y00AP	AIR GUIDE A	1	
20		F41449Y10QP	ORIFICE	1	
21		J607S4T00AP	STEAM SENSOR	1	
22		F64499Y00AP	SENSOR COVER A	1	
24		F64508660AP	SENSOR COVER B	1	
25		F65439Y00AP	SENSOR COVER C	1	
26	\triangle	F61425U30XN	MICRO SWITCH	1	(PRIMARY LATCH SWITCH)
27	\triangle	F61415U30XN	MICRO SWITCH	1	(SECONDARY LATCH SWITCH)
28	\triangle	F61459V00XP	THERMAL CUTOFF	1	
29		F612E9V00XP	INCANDESCENT LAMP (U)	1	
30	\triangle	F61785U30XN	MICRO SWITCH	1	(SHORT SWITCH)
31	\triangle	F606YBA00QP	H. V. INVERTER (U)	1	
32	\triangle	2M261-M39R	MAGNETRON	1	
33	\triangle	F62306V60BP	FUSE	1	
35		F66629Y00AP	GROUNDING PLATE	1	
36		F63269P00HP	TURNTABLE MOTOR	1	
37	\triangle	F900C9Y10QP	AC CORD W/PLUG	1	
38		F607X9J20QP	NOISE FILTER	1	
40		F30069Y00AP	HINGE A	1	
41		XTWFL4+12T	SCREW	4	FOR MAGNETRON
43		XTWFA4+12D	SCREW	4	FOR CABINET BODY
44		XTWFA4+12LR	SCREW	3	FOR HINGE A
45		F65859Y00AP	INVERTER BRACKET	1	
55		F31389X70EP	HOOK LEVER C	1	
56		F31369X70EP	HOOK LEVER A	1	
57		F31379X70EP	HOOK LEVER B	1	

8.3. ESCUTCHEON BASE ASSEMBLY

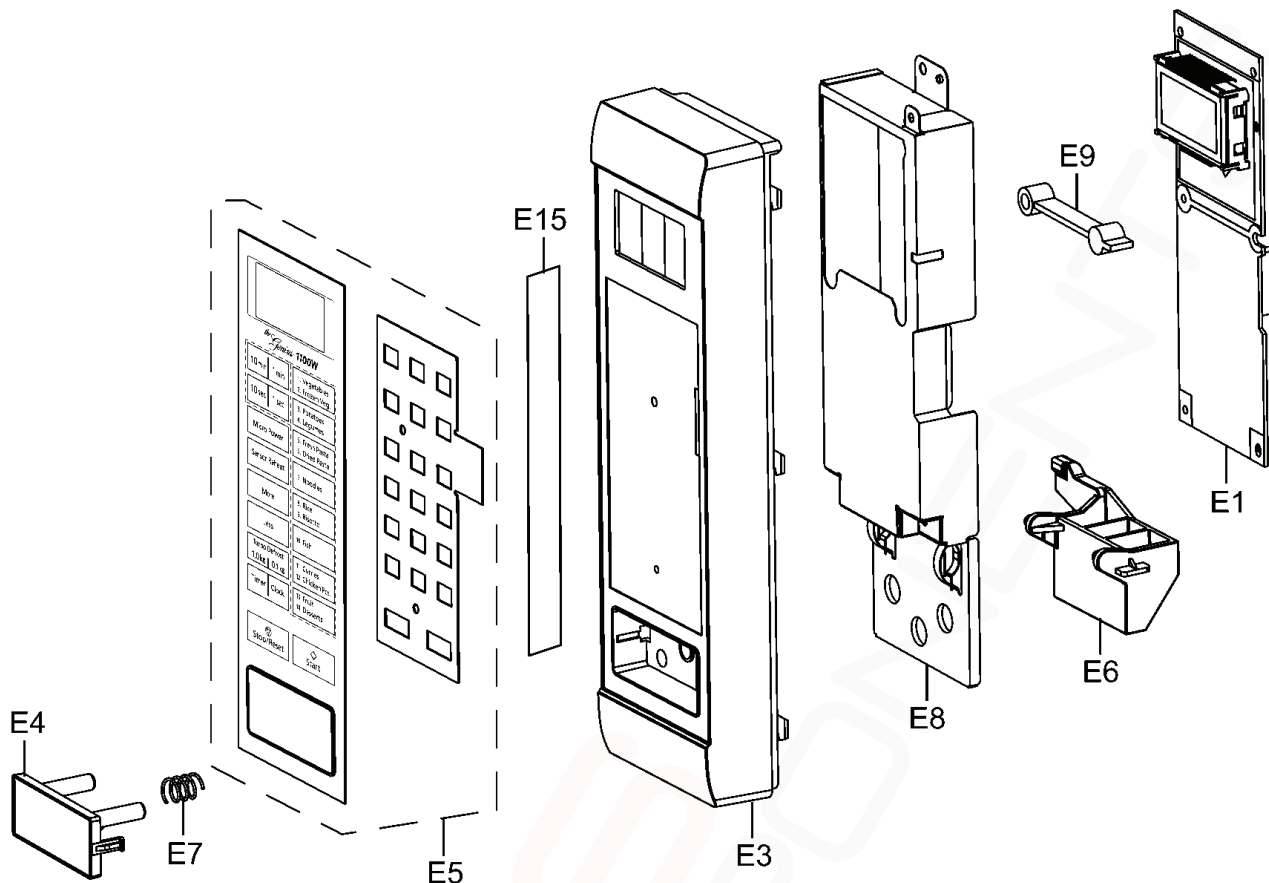

Ref. No.	Part No.	Part Name & Description	Pcs/Set	Remarks
E1	F603LBD10QP	D. P. CIRCUIT (AU)	1	
E3	F80349Y00HAP	ESCUTCHEON BASE	1	
E4	F891P9Y10BAP	DOOR OPENING BUTTON (U)	1	
E5	F630YBL50BQP	MEMBRANE SWITCH (U)	1	
E6	F82569Y00AP	DOOR OPENING LEVER	1	
E7	F80375K00AP	COOK BUTTON SPRING	1	
E8	F81279Y00AP	BACK PANEL	1	
E9	F66139Y20AP	BACKSTOP	1	
E15	F0007BL50HQP	NAME PLATE	1	

8.4. DOOR ASSEMBLY

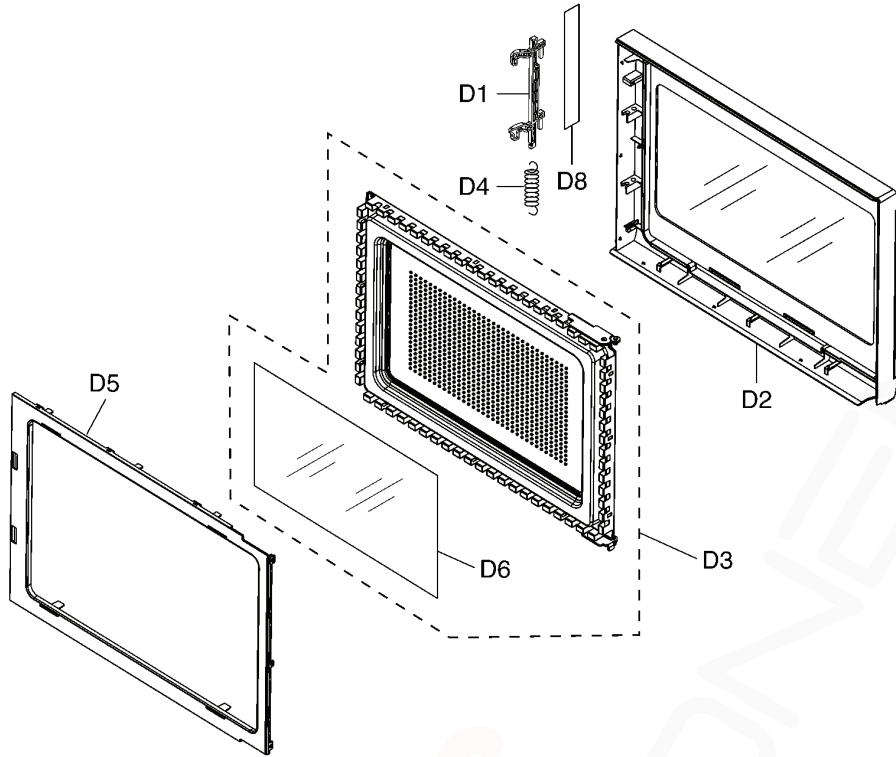

Ref. No.		Part No.	Part Name & Description	Pcs/Set	Remarks
D1		F30189Y00AP	DOOR KEY A	1	
D2	⚠	F302ABL50HQP	DOOR A (U)	1	
D3	⚠	F302K9Y00AP	DOOR E (U)	1	
D4		F30215G10XN	DOOR KEY SPRING	1	
D5	⚠	F30859Y00AP	DOOR C	1	
D6	⚠	F31459Y00AP	DOOR SCREEN A	1	
D8		F01726V00JP	CAUTION LABEL B	1	

8.5. WIRING MATERIALS

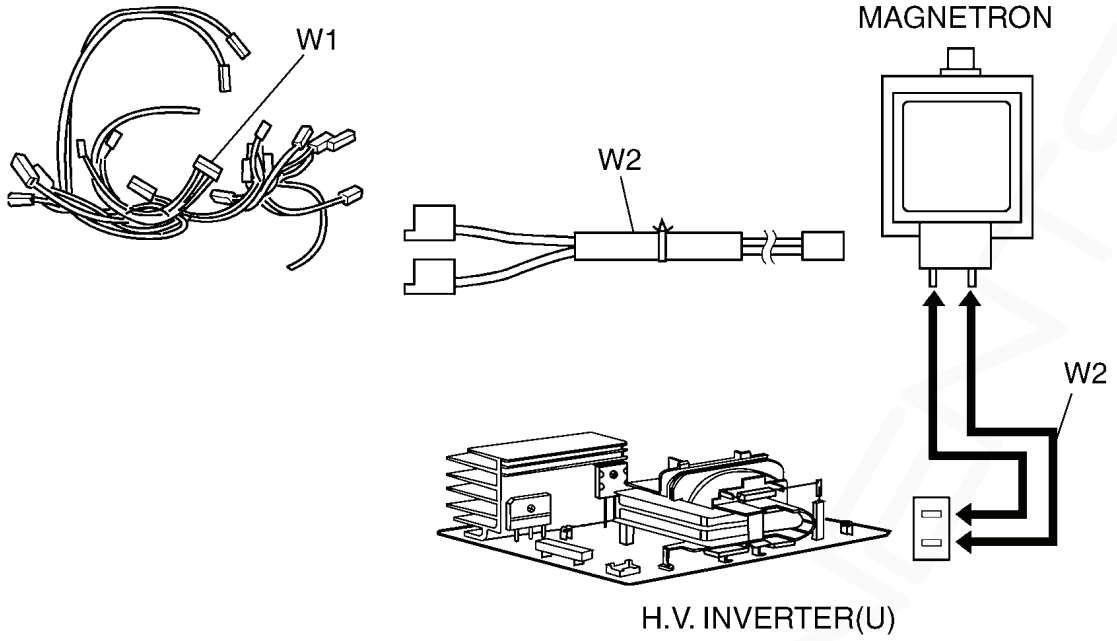

Ref. No.	Part No.	Part Name & Description	Pcs/Set	Remarks
W1	F030A9Y10QP	LEAD WIRE HARNESS	1	(INCLUDING MAGNETRON THERMISTOR)
W2	F030E9Y10QP	H.V. LEAD WIRE	1	

8.6. PACKING AND ACCESSORIES

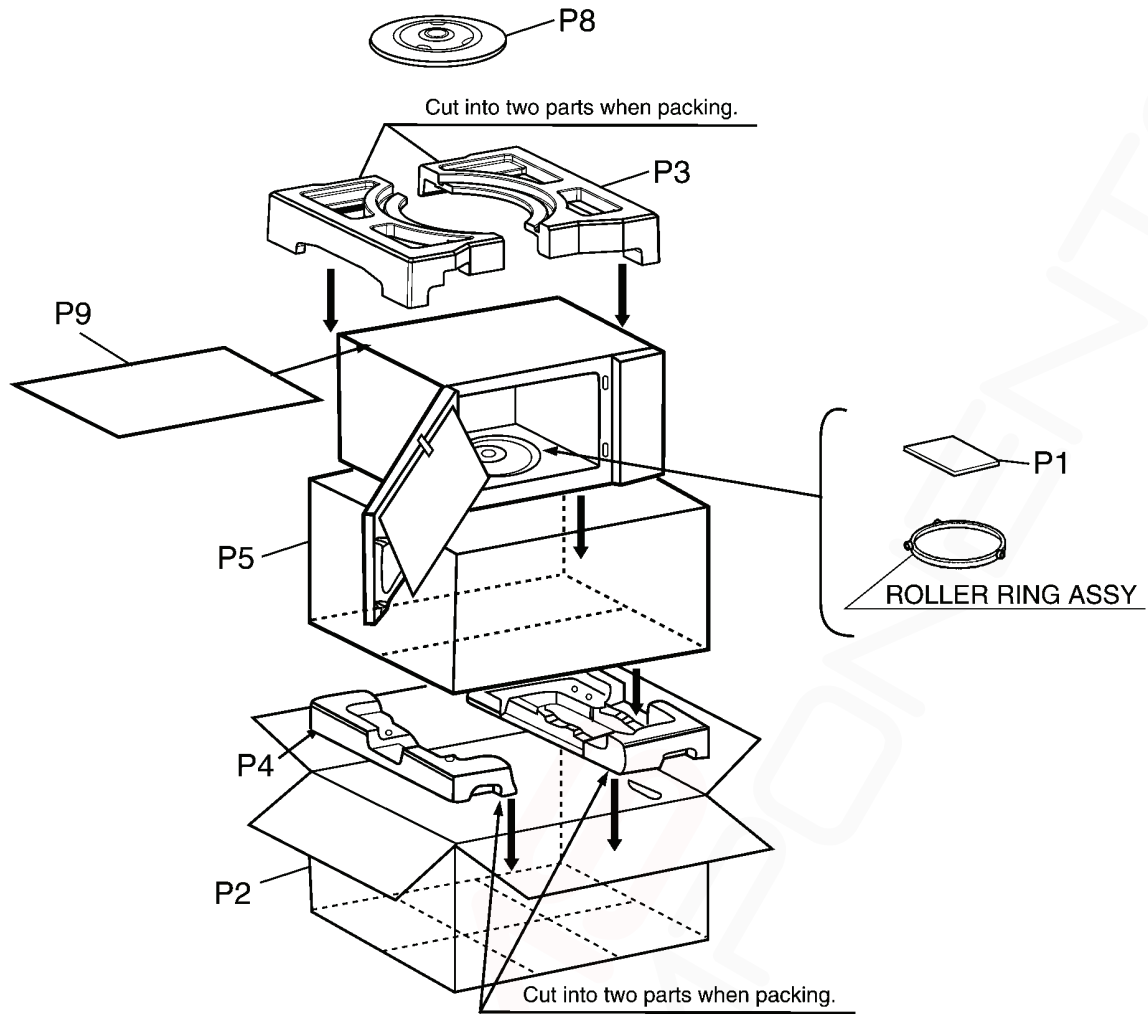

Ref. No.	Part No.	Part Name & Description	Pcs/Set	Remarks
P1	F00039Y50QP	INSTRUCTION MANUAL	1	
P2	F0102BL50HQP	PACKING CASE, PAPER	1	
P3	F01049Y00AP	UPPER FILLER	1	
P4	F01059Y00AP	LOWER FILLER	1	
P5	F01068100XN	P.E.BAG	1	
P8	E06014N30BP	COOKING TRAY	1	
P9	F01924T00AP	SHEET	1	