

Service Manual

Microwave Oven

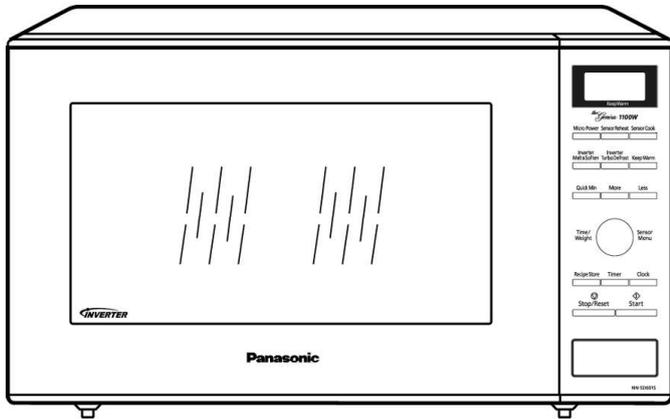

NN-SD691S
NN-ST671S
NN-ST651W
NN-ST641W

QPQ (Australia & New Zealand)

Specifications:

Specifications:	Model:	NN-SD691S	NN-ST671S	NN-ST651W	NN-ST641W
Power Source:	230V-240V AC Single Phase, 50Hz				
Power Consumption:		1000W	1000W	1000W	1000W
Output:		1100W	1100W	1100W	1100W
Microwave Frequency:	2450MHz				
Timer:	30 min. / Stage (HIGH Power) ~ 3 Stage Maximum 90 min. 00 sec / Stage (Other Power Levels) ~ 3 Stage Maximum.....(SD691S) 99 min. 99 sec / Stage (Other Power Levels) ~ 3 Stage Maximum.....(EXCEPT SD691S)				
Outside Dimensions (WxDxH):	525mm x 401mm x 310mm	525mm x 388mm x 310mm			
Oven Cavity Dimensions (WxDxH):	355mm x 365mm x 251mm				
Net Weight:		12kg	11.5kg	11.5kg	11.5kg
PbF	This product with PbF				
Specifications subject to change without notice.					

8 EXPLODED VIEW AND PARTS LIST

8.1. EXPLODED VIEW

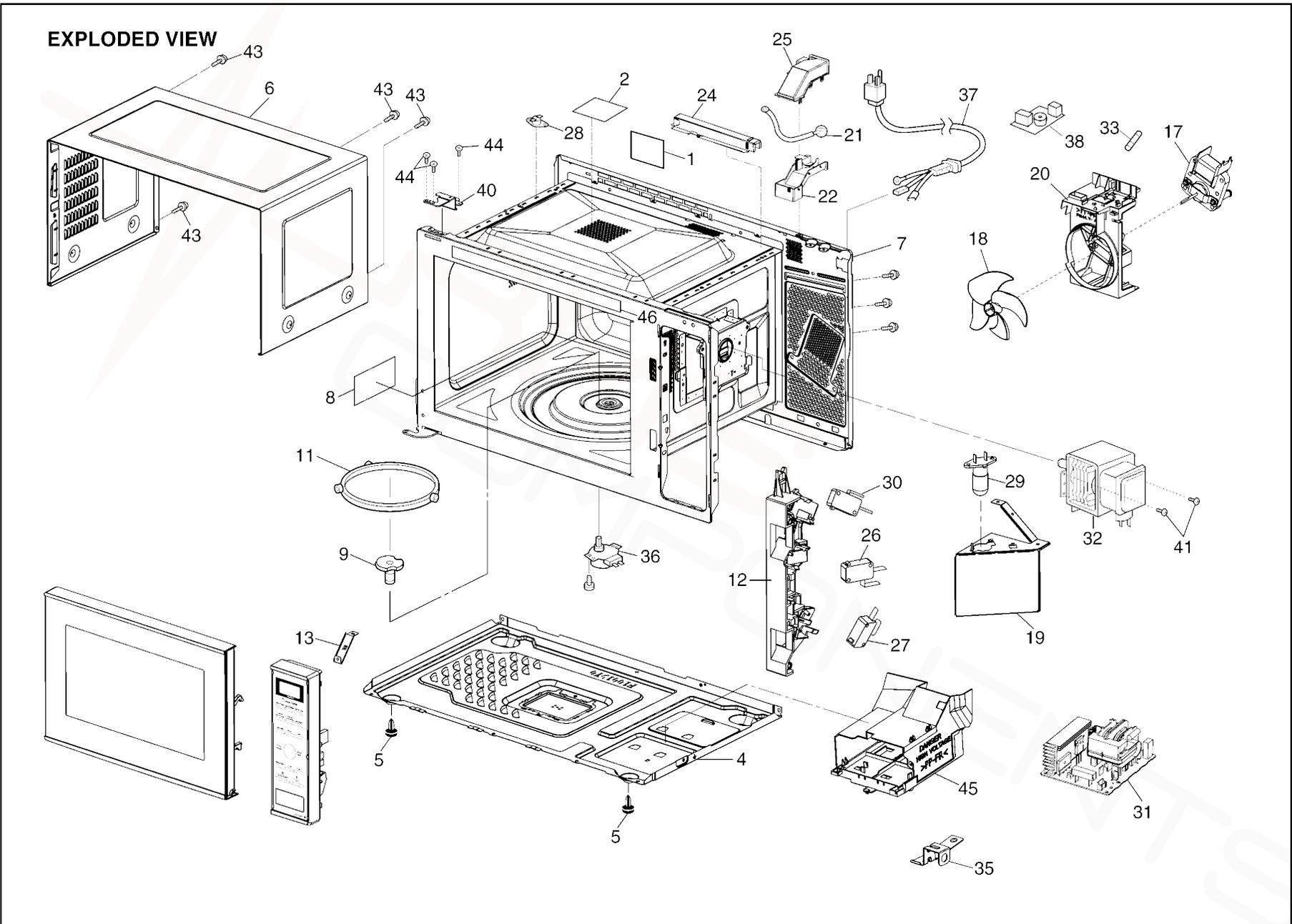

8.2. PARTS LIST

NOTE:

1. When ordering replacement part(s), please use part number(s) shown in this part list.
Do not use description of the part.
2. Important safety notice:
Components identified by \triangle mark have special characteristics important for safety.
When replacing any of these components, use only manufacture's specified parts.

Ref. No.	Part No.	Part Name & Description	Pcs/Set	Remarks
1	F00066V00HP	CAUTION LABEL	1	
2	F21559Y10QP	OVEN STICKY PAPER	1	
4	F10019Y00AP	BASE	1	
5	F10089W40HPS	RUBBER FOOT	2	
6	F10099Y00SAP	CABINET BODY (U)	1	SD691S,ST671S
6	F10099Y00HAP	CABINET BODY (U)	1	ST651W,ST641W
7	\triangle F200A9Y00SQP	OVEN (U)	1	SD691S,ST671S,ST651W
7	\triangle F200A9Y10SQP	OVEN (U)	1	ST641W
8	F20559Y00AP	COVER	1	
9	F21319Y00AP	PULLY SHAFT	1	
11	F290D6W50XP	ROLLER RING (U)	1	
12	\triangle F30209Y00AP	DOOR HOOK	1	
13	F11619Y00AP	REINFORCEMENT BRACKET	1	
17	F400A9Y00QP	FAN MOTOR	1	
18	F40089Y00AP	FAN BLADE	1	
19	F40259Y00AP	AIR GUIDE A	1	
20	F41449Y10QP	ORIFICE	1	
21	J607S4T00AP	STEAM SENSOR	1	SD691S,ST671S,ST651W
22	F64499Y00AP	SENSOR COVER A	1	SD691S,ST671S,ST651W
24	F64508660AP	SENSOR COVER B	1	SD691S,ST671S,ST651W
25	F65439Y00AP	SENSOR COVER C	1	SD691S,ST671S,ST651W
26	\triangle F61425U30XN	MICRO SWITCH	1	(PRIMARY LATCH SWITCH)
27	\triangle F61415U30XN	MICRO SWITCH	1	(SECONDARY LATCH SWITCH)
28	\triangle F61459V00XP	THERMAL CUTOUT	1	
29	F612E9C30BP	INCANDESCENT LAMP (U)	1	
30	\triangle F61785U30XN	MICRO SWITCH	1	(SHORT SWITCH)
31	\triangle F606YBA00GP	H.V. INVERTER (U)	1	
32	\triangle 2M261-M39R	MAGNETRON	1	
33	\triangle F62306V60BP	FUSE	1	
35	F66629Y00AP	GROUNDING PLATE	1	
36	F63266S30XP	TURNTABLE MOTOR	1	
37	\triangle F900C9Y10QP	AC CORD W/PLUG	1	
38	F607X9J20QP	NOISE FILTER	1	
40	F30069Y00AP	HINGE A	1	
41	XTWFL4+12T	SCREW	2	FOR MAGNETRON
43	XTWFA4+12D	SCREW	4	FOR CABINET BODY
44	XTWFA4+12LR	SCREW	3	FOR HINGE A
45	F65859Y00AP	INVERTER BRACKET	1	
46	F03349Y40QP	MENU LABEL	1	SD691S

8.3. ESCUTCHEON BASE ASSEMBLY

8.3.1. NN-SD691S

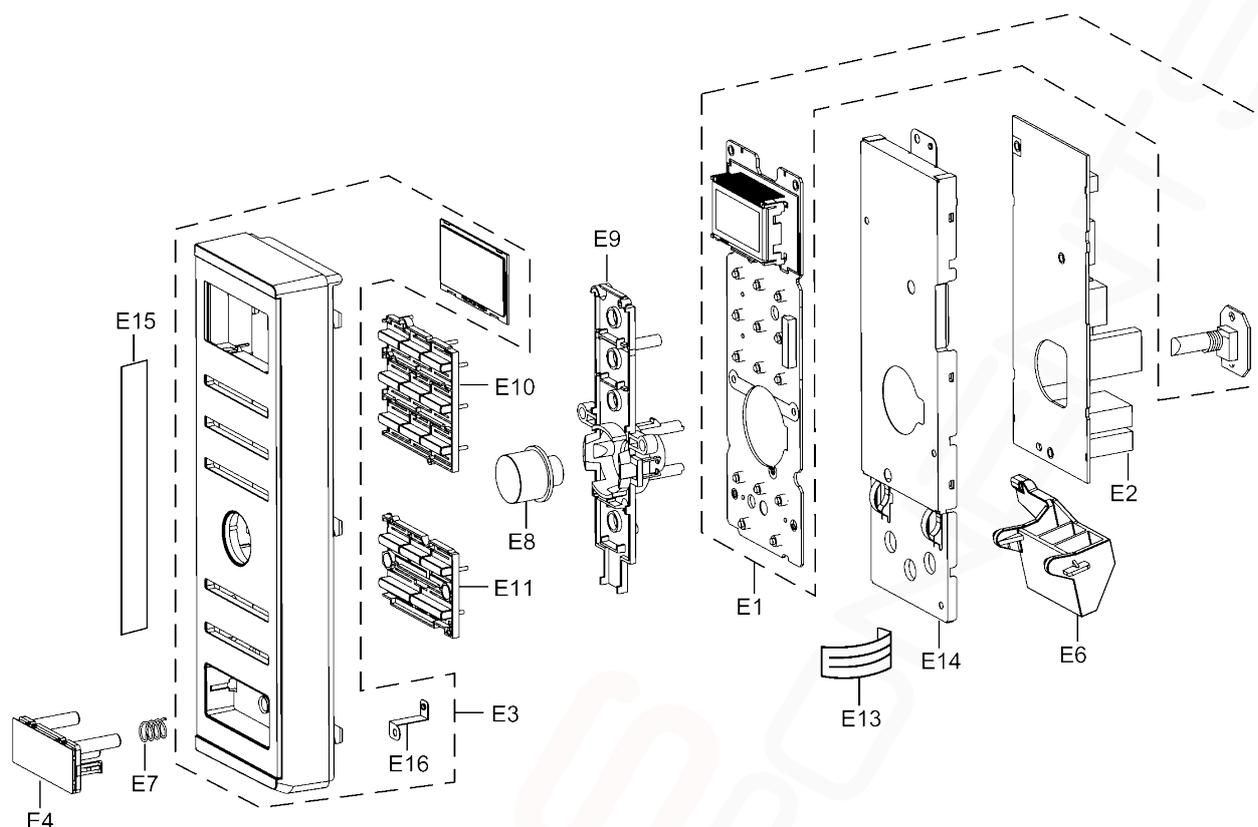

Ref. No.	Part No.	Part Name & Description	Pcs/Set	Remarks
E1	F603L9Y40QP	D.P.CIRCUIT (AU)	1	SD691S
E2	F603Y9Y40QP	D.P.CIRCUIT (DU)	1	SD691S
E3	F800L9Y40SQP	ESCUTCHEON BASE (U)	1	SD691S
E4	F891P9Y40NAP	DOOR OPENING BUTTON (U)	1	SD691S
E6	F82569Y00AP	DOOR OPENING LEVER	1	
E7	F80375K00AP	COOK BUTON SPRING	1	
E8	F803G9M60SBP	POP-OUT DIAL (U)	1	SD691S
E9	F80189Y40AP	DIAL SUPPORT	1	SD691S
E10	F82989Y40SAP	BUTTON	1	SD691S
E11	F82989Y90SAP	BUTTON B	1	SD691S
E13	F66167D00AP	FLAT CABLE	1	SD691S
E14	F81279Y40AP	BACK PANEL	1	SD691S
E15	F00079Y40SQP	NAME PLATE	1	SD691S
E16	F33169Y40AP	GROUNDING METAL	1	SD691S

8.3.2. NN-ST671S

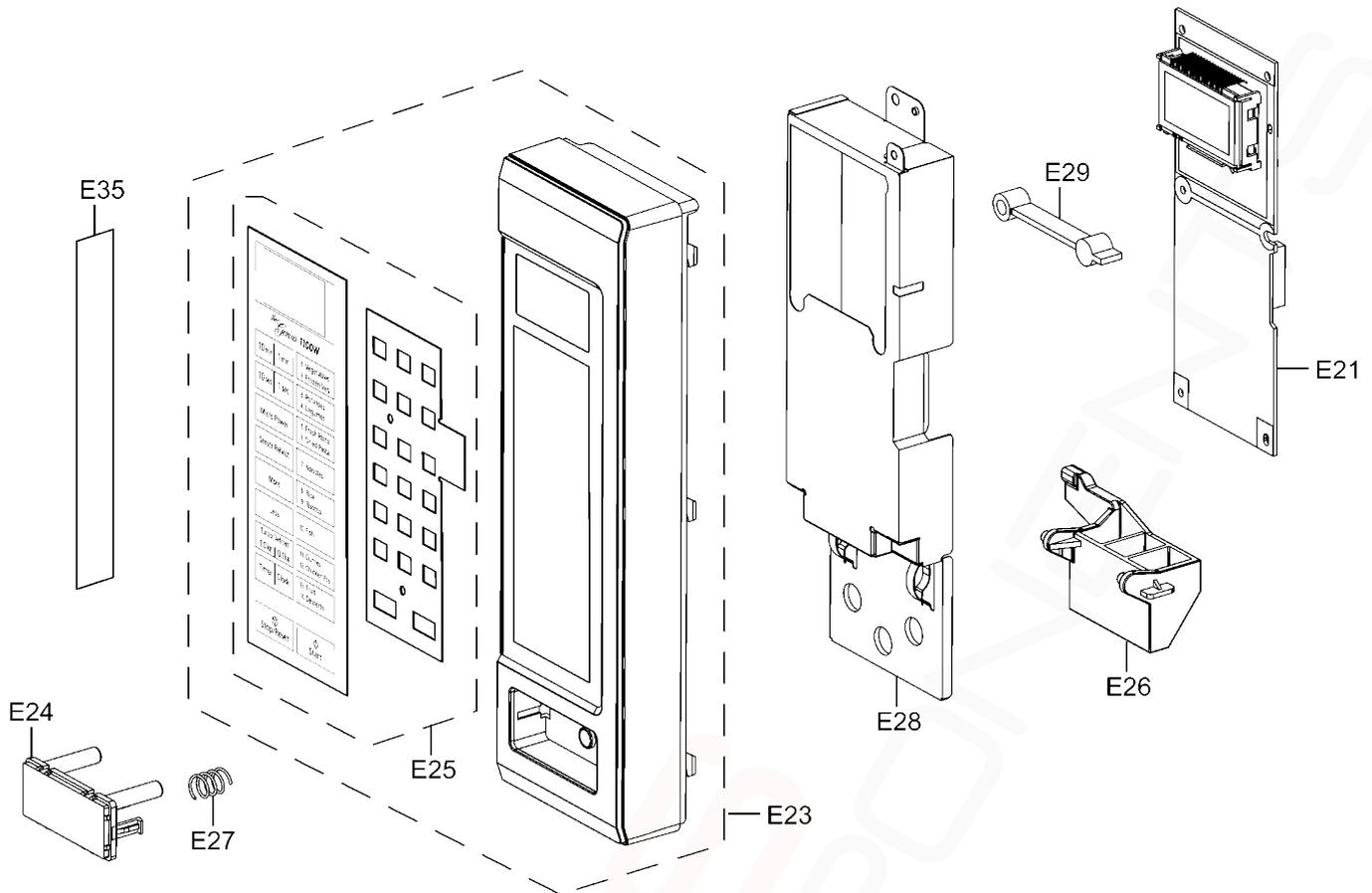

Ref. No.	Part No.	Part Name & Description	Pcs/Set	Remarks
E21	F603LBD10QP	D.P.CIRCUIT (AU)	1	ST671S
E23	F800LBD10SQP	ESCUTCHEON BASE (U)	1	ST671S
E24	F891P9Y20SAP	DOOR OPENING BUTTON (U)	1	ST671S
E25	F630YBD10BQP	MEMBRANE SWITCH (U)	1	ST671S
E26	F82569Y00AP	DOOR OPENING LEVER	1	
E27	F80375K00AP	COOK BUTTON SPRING	1	
E28	F81279Y20AP	BACK PANEL	1	ST671S
E29	F66139Y00AP	BACKSTOP	1	ST671S
E35	F0007BD10SQP	NAME PLATE	1	ST671S

8.3.3. NN-ST651W, ST641W

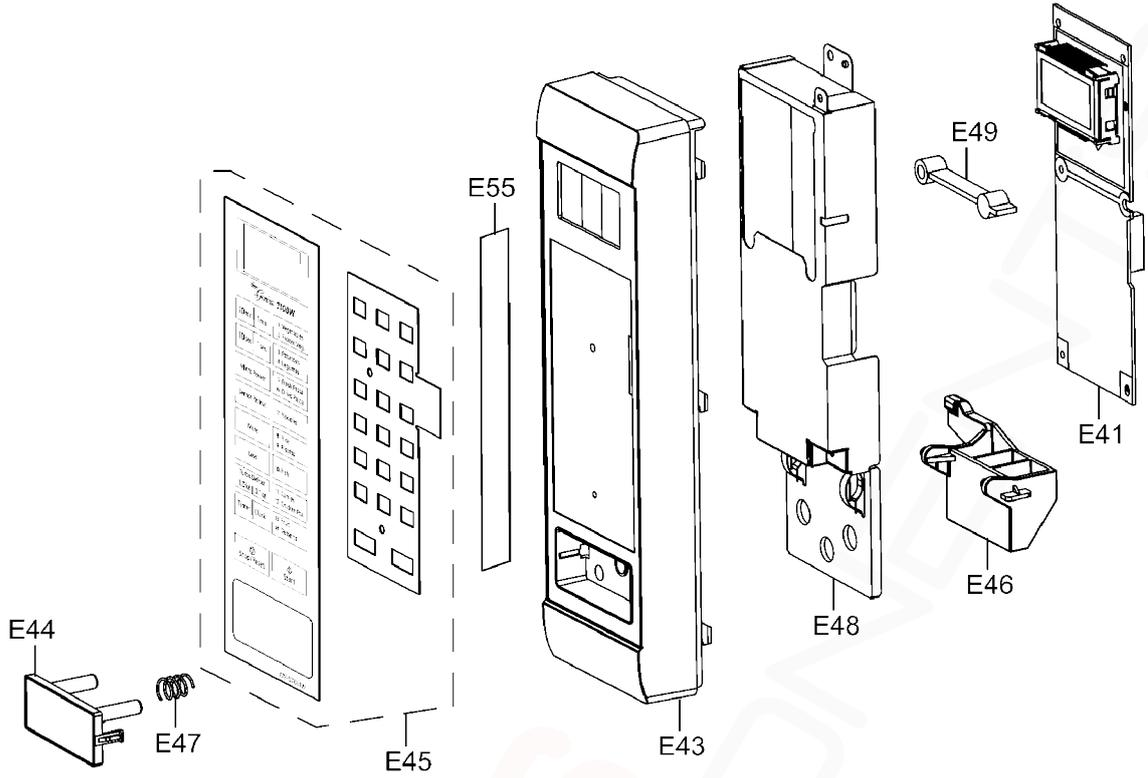

Ref. No.	Part No.	Part Name & Description	Pcs/Set	Remarks
E41	F603LBD10QP	D. P. CIRCUIT (AU)	1	ST651W
E41	F603L9Y10QP	D. P. CIRCUIT (AU)	1	ST641W
E43	F80349Y10HAP	ESCUTCHEON BASE	1	ST651W, ST641W
E44	F80729Y00BAP	DOOR OPENING BUTTON	1	ST651W, ST641W
E45	F630Y9Y50BQP	MEMBRANE SWITCH (U)	1	ST651W
E45	F630Y9Y10BQP	MEMBRANE SWITCH (U)	1	ST641W
E46	F82569Y00AP	DOOR OPENING LEVER	1	
E47	F80375K00AP	COOK BUTTON SPRING	1	
E48	F81279Y00AP	BACK PANEL	1	ST651W, ST641W
E49	F66139Y00AP	BACKSTOP	1	ST651W, ST641W
E55	F00079Y50HQP	NAME PLATE	1	ST651W
E55	F00079Y10HQP	NAME PLATE	1	ST641W

8.4. DOOR ASSEMBLY

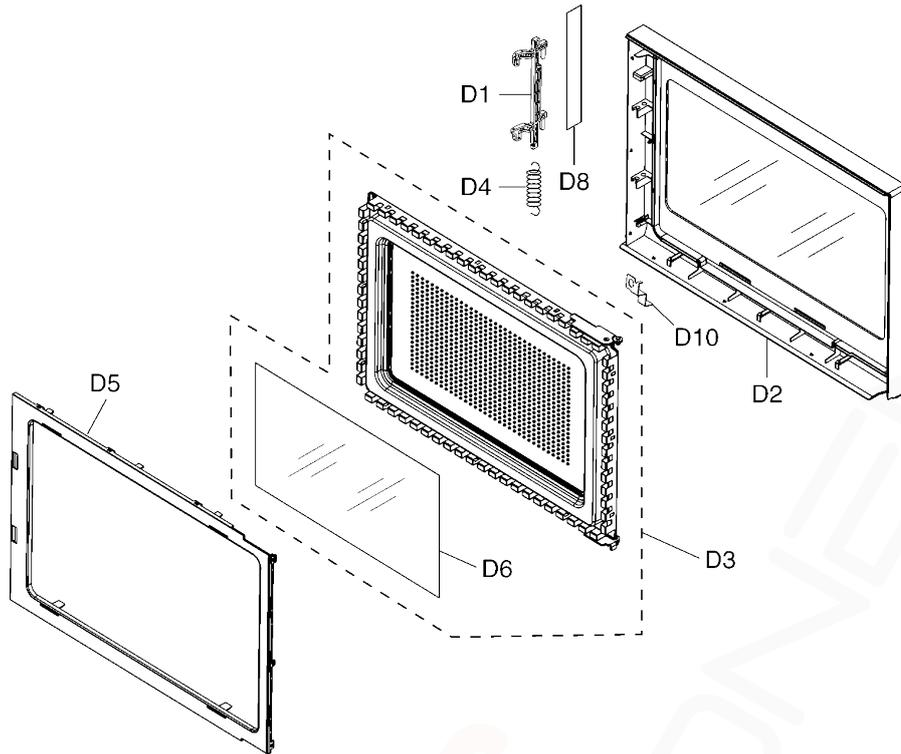

Ref. No.		Part No.	Part Name & Description	Pcs/Set	Remarks
D1		F30189Y00AP	DOOR KEY A	1	
D2	△	F302A9Y40SAP	DOOR A (U)	1	SD691S
D2	△	F302A9Y20SAP	DOOR A (U)	1	ST671S
D2	△	F302A9Y10HAP	DOOR A (U)	1	ST651W, ST641W
D3	△	F302K9Y00AP	DOOR E (U)	1	
D4		F30215G10XN	DOOR KEY SPRING	1	
D5	△	F30859Y00AP	DOOR C	1	
D6	△	F31459Y00AP	DOOR SCREEN A	1	
D8		F01726V00JP	CAUTION LABEL B	1	
D10		F66629Y40AP	GROUNDING METAL	1	SD691S

8.5. WIRING MATERIALS

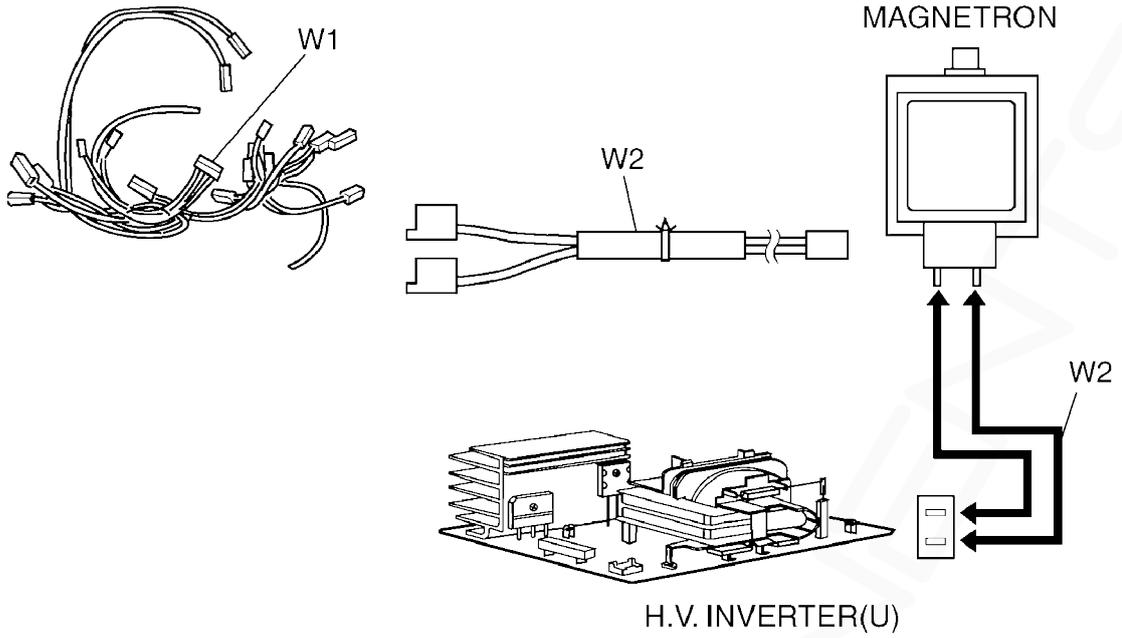

Ref. No.	Part No.	Part Name & Description	Pcs/Set	Remarks
W1	F030A9Y10QP	LEAD WIRE HARNESS	1	(INCLUDING MAGNETRON THERMISTOR)
W2	F030E9Y10QP	H.V. LEAD WIRE	1	

8.6. PACKING AND ACCESSORIES

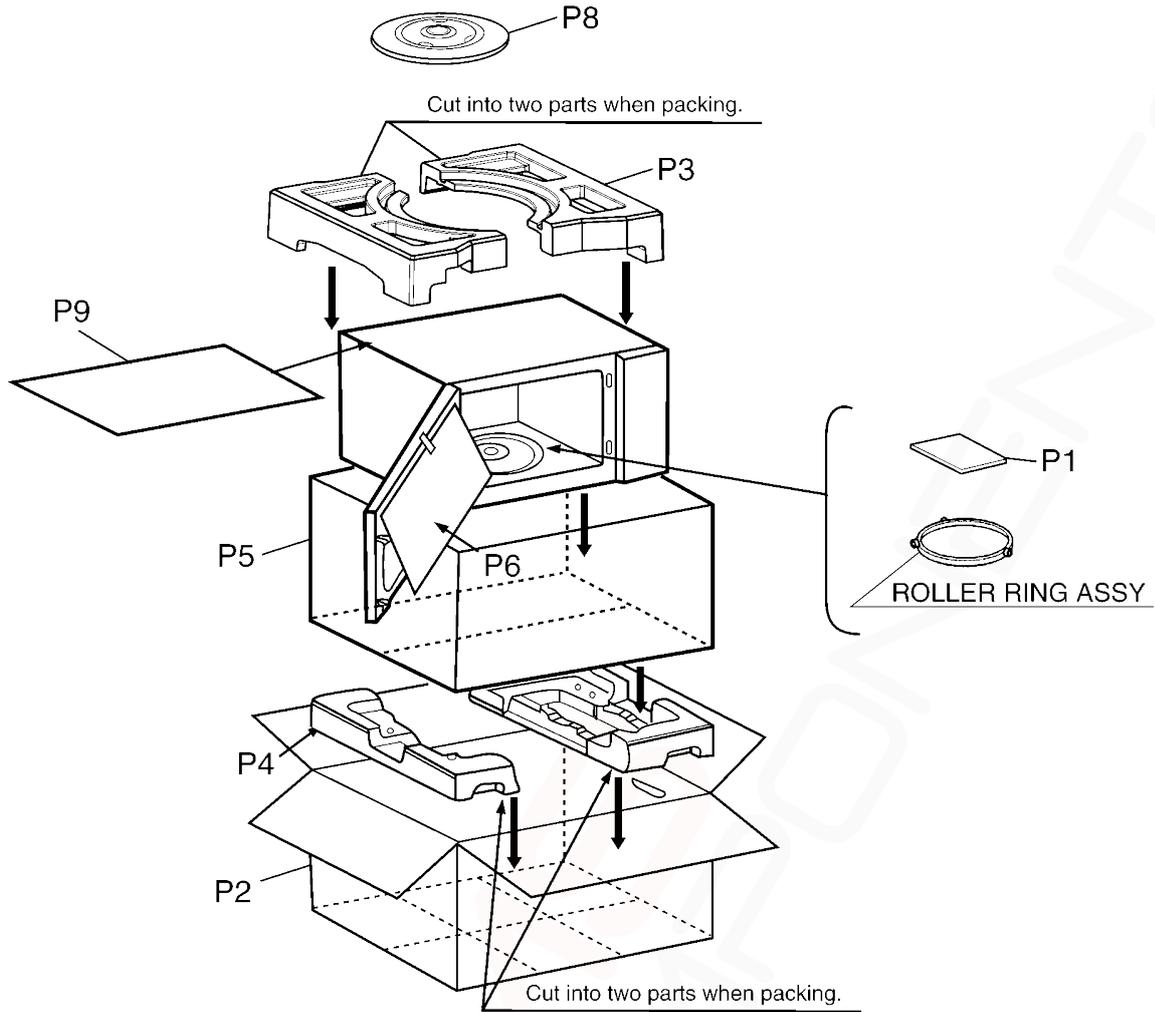

Ref. No.	Part No.	Part Name & Description	Pcs/Set	Remarks
P1	F00039Y40QP	INSTRUCTION MANUAL	1	SD691S
P1	F00039Y50QP	INSTRUCTION MANUAL	1	ST671S, ST651W
P1	F00039Y10QP	INSTRUCTION MANUAL	1	ST641W
P2	F01029Y40SQP	PACKING CASE, PAPER	1	SD691S
P2	F0102BD10SQP	PACKING CASE, PAPER	1	ST671S
P2	F01029Y50HQP	PACKING CASE, PAPER	1	ST651W
P2	F01029Y10HQP	PACKING CASE, PAPER	1	ST641W
P3	F01049Y00AP	UPPER FILLER	1	
P4	F01059Y00AP	LOWER FILLER	1	
P5	F01068100XN	P.E. BAG	1	
P6	F01078J00XN	DOOR SHEET	1	
P8	F06015Q00AP	COOKING TRAY	1	
P9	F01924T00AP	SHEET	1	