

Service Manual

Microwave Oven

NN-CF874B

QPQ (Australia & New Zealand)



Specification

Models		NN-CF874B
Power Source:		230V ~ 240V AC Single Phase, 50Hz
Power Consumption:	Microwave	990W
	Grill	1330W
	Convection	1380W
Output:	Microwave	1000W
	Grill	1300W
	Convection	1350W
Microwave Frequency:		2450MHz
Timer:		30min. /Stage (1000W Power) ~ 3 Stage Maximum 90min. 00 sec/Stage (Other Power Levels) ~ 3 Stage Maximum
Outside Dimensions:		494mm(W) x 438mm(D) x 390mm(H)
Oven Cavity Dimensions:		410mm(W) x 320mm(D) x 250mm(H)
Weight:		20kg
PbF		This product with PbF
Specifications subject to change without notice.		

8 EXPLODED VIEW AND PARTS LIST

8.1. EXPLODED VIEW

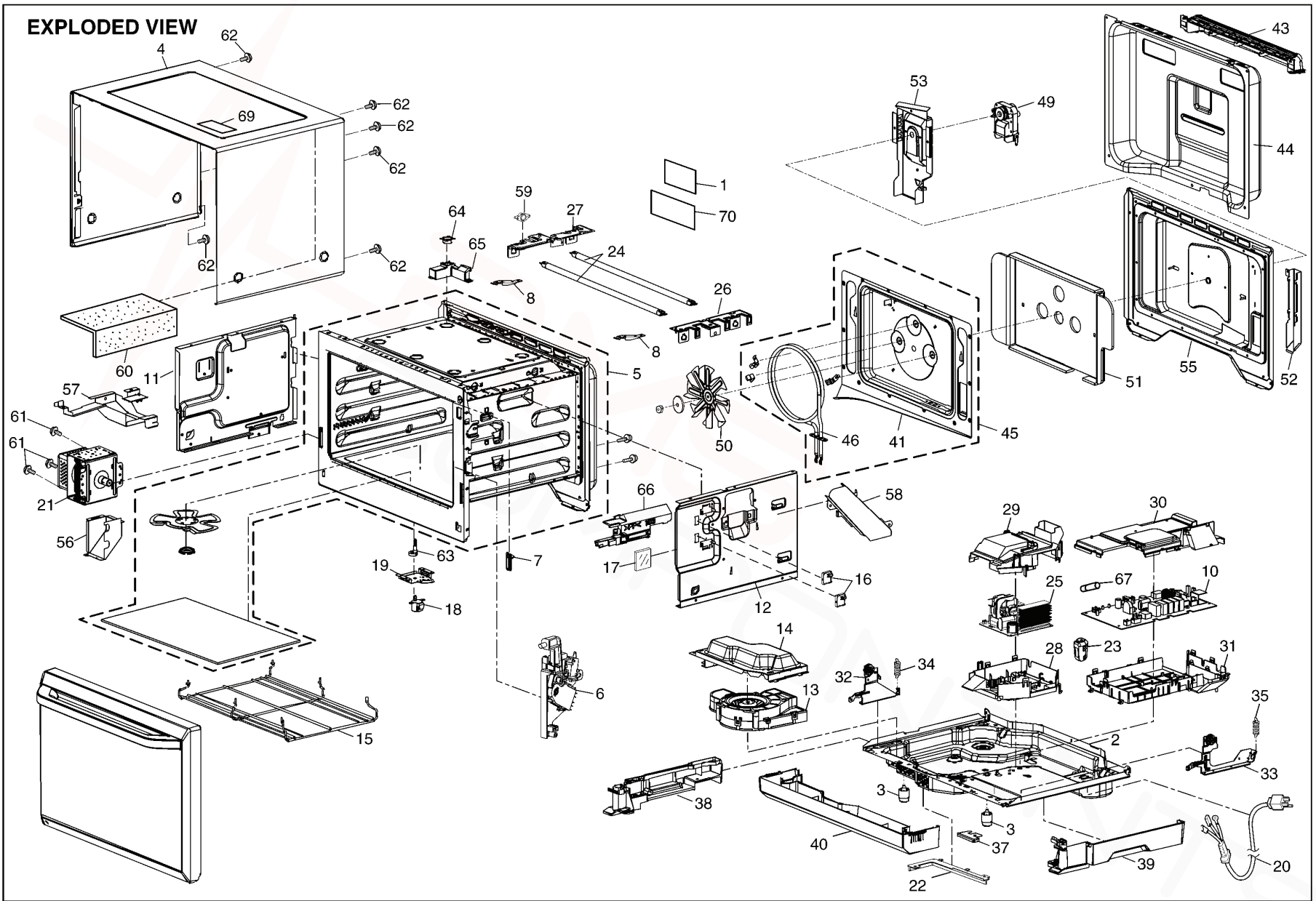

8.2. PARTS LIST

NOTE:

1. When ordering replacement part(s), please use part number(s) shown in this part list.

Do not use description of the part.

2. Important safety notice:

Components identified by Δ mark have special characteristics important for safety.

When replacing any of these components, use only manufacture's specified parts.

Ref. No.		Part No.	Part Name & Description	Pcs/Set	Remarks
1		F00066V00HP	CAUTION LABEL	1	
2		F1001BH20BP	BASE	1	
3		F1008-1S30S	RUBBER FOOT	2	
4		F1009-1S30k	CABINET BODY	1	
5	Δ	F200ABH20BP	OVEN	1	INCLUDING FLAT TABLE (U) , ANTENNA STIRRER (U) & STIRRER BRACKET
6	Δ	J300W-1H10	DOOR HOOK (U)	1	
7		F3105-1900	LATCH GUIDE A	1	
8		F2034-1S30	REINFORCEMENT BRACKET A	2	
10		F603LBH20QP	D.P.CIRCUIT (AU)	1	
11		F2237-1S30	LEFT HEATER PANEL	1	
12		F2236BH20BP	RIGHT HEATER PANEL	1	
13		F400A-1S30	FAN MOTOR	1	
14		F4021BH20BP	FAN CASE COVER	1	
15		F6735BH20BP	HEATER PROTECTOR	1	
16		F612E-1S50	LAMP (U)	2	LED LAMP INSIDE
17		F6437-1S30	GLASS	1	
18		A6760-1N40	STIRRER MOTOR	1	
19		F6640-1S30	MOTOR BRACKET	1	
20	Δ	F900CBH20QP	AC CORD W/PLUG	1	
21	Δ	2M261-M36J1B	MAGNETRON	1	
22		F4205-1S30	AIR SLOT	1	
23		F50968K30BP	FERRITE CORE	1	
24		F630HBH20BP	HEATER BU	2	
25		F606YBH20GP	H.V.INVERTER (U)	1	
26		F6553-1S30	HEATER BRACKET	1	
27		F6641-1S30	HEATER BRACKET	1	
28		F6585BH20BP	INVERTER BRACKET	1	
29		F6720BH20BP	INVERTER COVER A	1	
30		F6721-1S30	PCB COVER B	1	
31		F6763-1S30	PCB BRACKET B	1	
32		F300B-1S30	LEFT HINGE (U)	1	
33		F300U-1S30	RIGHT HINGE (U)	1	
34		F3230-1P50	DOOR KEY SPRING B	1	
35		F3230-1P50	DOOR KEY SPRING B	1	
37		F6241BH20BP	RIGHT SHEET	1	
38		F8028-1S30	LEFT DRIP TRAY	1	
39		F8027BH20BP	RIGHT DRIP TRAY	1	
40		F8023BH20BP	DRIP TRAY	1	
41		F2328-1S30	CONVECTION FAN CASE	1	
43		F4120BH20BP	EXHAUST GUIDE		
44		F1183BH20BP	REAR COVER B	1	
45		F203MBH20BP	CONVECTION FAN (U)	1	
46		F631DBH20BP	HEATER CU	1	
49		F4179BH20BP	CONVECTION FAN MOTOR	1	
50		F2239-1S30	CONVECTION FAN BLADE	1	
51		F2242-1S30	ADIABATIC MATERIAL	1	
52		F4024-1S30	EXHAUST GUIDE A	1	
53		F4180-1S30	CONVECTION FAN BRACKET	1	
55		F1004-1S30	REAR PLATE	1	
56		F4030-1S30	AIR GUIDE D	1	
57		F4042-1S30	AIR GUIDE F	1	

Ref. No.		Part No.	Part Name & Description	Pcs/Set	Remarks
58		F4047BH20BP	AIR GUIDE E	1	
59	△	F6145BH20BP	THERMAL CUTOUT	1	205°C OPEN
60		F1221-1S30	CUSHION RUBBER	1	FOR CABINET BODY
61		XTWFL4+12T	SCREW	3	FOR MAGNETRON
62		XTT4+8RDN	SCREW	6	FOR CABINET BODY
63		F2081-1S30	SHAFT	1	
64		A601LBH20BP	SENSOR U	1	
65		F6449BH20BP	SENSOR COVER	1	
66		F6392-1S30	HARNESS PROTECTOR	1	
67	△	F62309W40HP	FUSE	1	10A
69		F0150BH20BP	NO TOUCHING LABEL	1	
70		F0157BH20BQP	NAME PLATE	1	

8.3. DOOR & ESCUTCHEON BASE ASSEMBLY

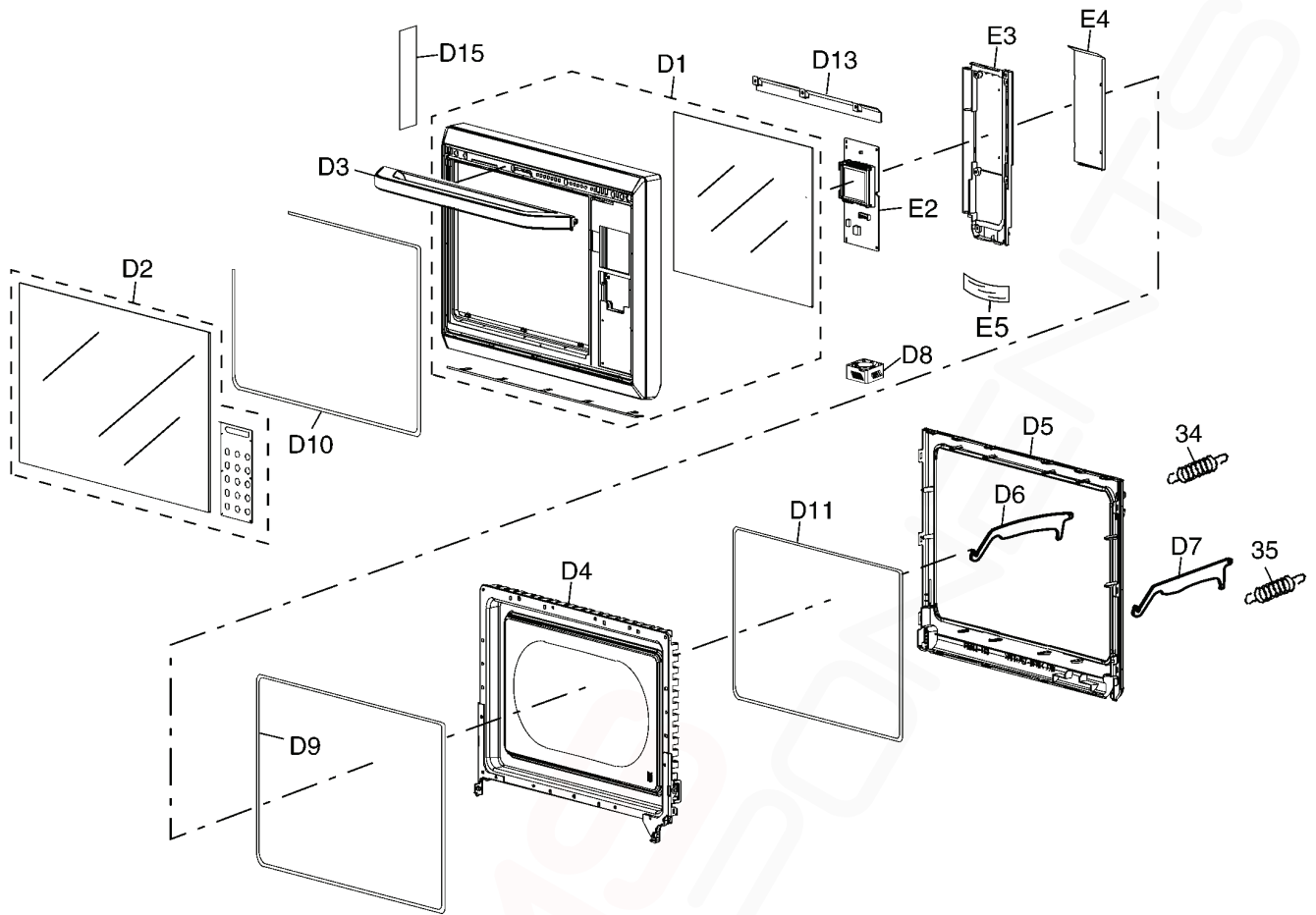

Ref. No.	Part No.	Part Name & Description	Pcs/Set	Remarks
D1	F302ABH20BBP	DOOR A (U)	1	
D2	F302NBH20QP	DOOR SCREEN B (U)	1	(INCLUDING DOOR SCREEN B & D.P.C. (BU))
D3	F301FBH20BP	DOOR HANDLE U	1	
D4	△ A301QBH20BP	DOOR E (U)	1	
D5	△ F3085-1S30	DOOR C	1	
D6	F3044-1S40	DOOR ARM (RIGHT)	1	
D7	F3054-1S30	DOOR ARM (LEFT)	1	
D8	F400LBH20BP	FAN MOTOR BU	1	FOR COOLING DOOR
D9	A3198-1K20	DOOR SEAL	1	
D10	A3198BH20BP	SEAL A	1	
D11	A3334-1S30	SEAL	1	
D13	F6243BH20BP	HEAT INSULATION PLATE B	1	
D15	F01726V00JP	CAUTION LABEL B	1	
34	F3230-1P50	DOOR KEY SPRING B	1	
35	F3230-1P50	DOOR KEY SPRING B	1	

Ref. No.	Part No.	Part Name & Description	Pcs/Set	Remarks
E2	F605QBH20QP	D.P.CIRCUIT (FU)	1	
E3	F8034BH20BP	ESCUTCHEON BASE	1	
E4	F6244BH20BP	HEAT INSULATION PANEL	1	
E5	F6616BH20BP	FLAT CABLE	1	

8.4. WIRING MATERIALS

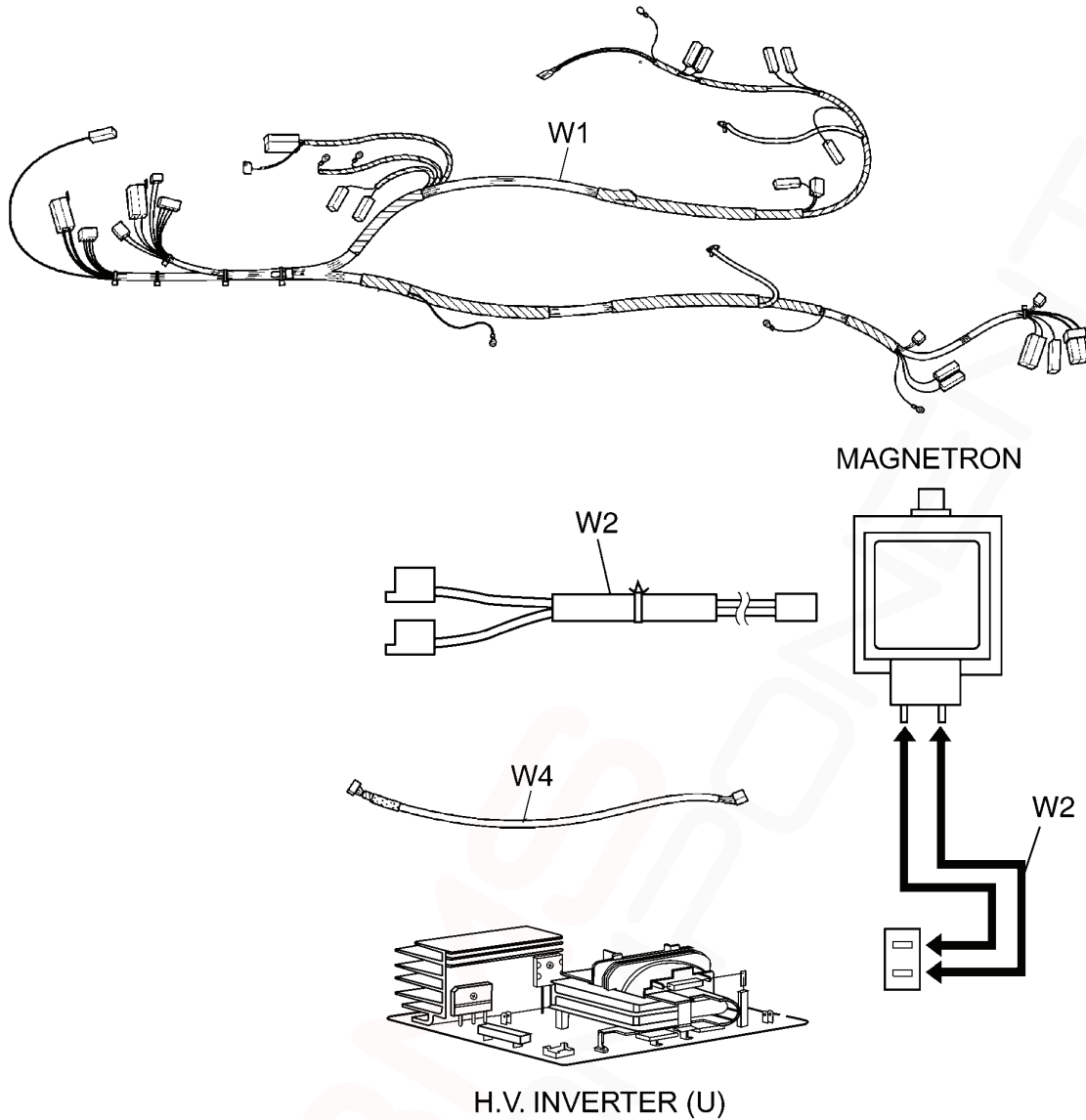

Ref. No.	Part No.	Part Name & Description	Pcs/Set	Remarks
W1	F030ABH20QP	LEAD WIRE HARNESS	1	(INCLUDING OVEN THERMISTOR)
W2	F030EBH20BP	H.V. LEAD WIRE	1	(MAGNETRON ~ H.V INVERTER (U))
W4	F0387BH20BP	LEAD WIRE HARNESS	1	(D.P.CIRCUIT (FU) ~ D.P.CIRCUIT (AU))