

Service Manual

Microwave Oven

NN-CF781S

QPQ (Australia & New Zealand)

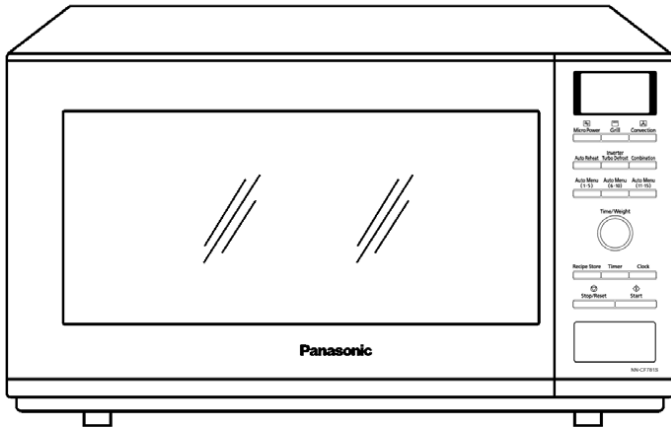

Specification

Models		NN-CF781S
Power Source:		230V-240V AC Single Phase, 50Hz
Power Consumption:	Microwave	860W
	Ceramic Heater	1020W
	Convection Heater	1450W
Output:	Microwave	1000W
	Ceramic Heater	1000W
	Convection Heater	1400W
Microwave Frequency:		2450MHz
Timer:		90 Min. 00 Sec.
Outside Dimensions:		529mm(W) x 494mm(D) x 326mm(H)
Oven Cavity Dimensions:		354mm(W) x 343mm(D) x 205mm(H)
Weight:		16kg
PbF		This product with PbF
Specifications subject to change without notice.		

10 EXPLODED VIEW AND PARTS LIST

10.1. EXPLODED VIEW

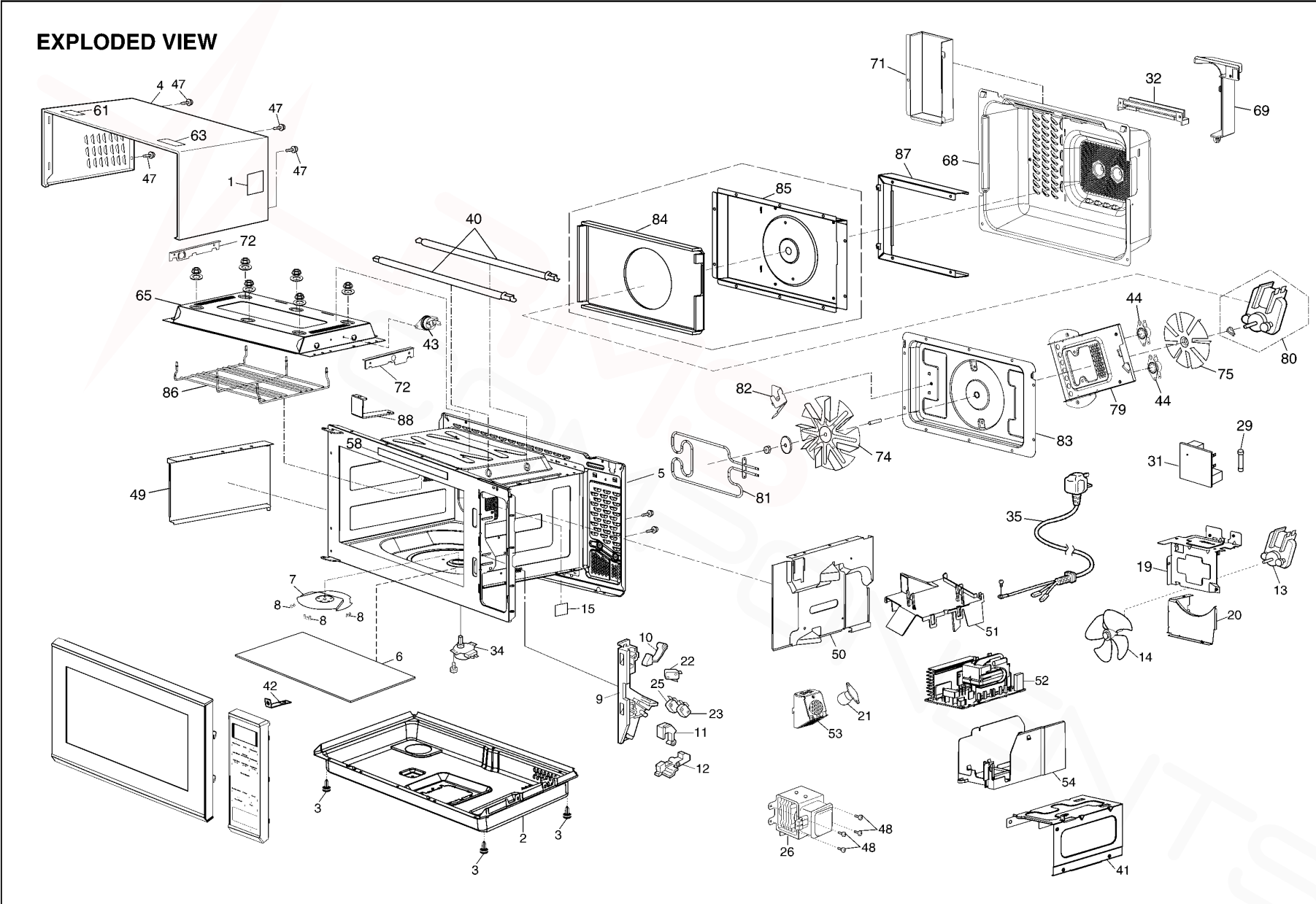

10.2. PARTS LIST

NOTE:

1. When ordering replacement part(s), please use part number(s) shown in this part list.

Do not use description of the part.

2. Important safety notice:

Components identified by \triangle mark have special characteristics important for safety.

When replacing any of these components, use only manufacture's specified parts.

Ref. No.	Part No.	Part Name & Description	Pcs/Set	Remarks
1	F00066V00HP	CAUTION LABEL	1	
2	F10019L10XPG	BASE	1	
3	F1008-1L40BS	RUBBER FOOT	4	
4	F10099N00SBP	CABINET BODY	1	
5	\triangle F200A9M50QP	OVEN	1	
6	A010T7R00SP	FLAT TABLE (U)	1	
7	F202K7R00BP	ANTENNA STIRRER (U)	1	
8	F20197J70XP	ANTENNA BRACKET	3	
9	\triangle F30206G30AP	DOOR HOOK	1	
10	F31366G30AP	HOOK LEVER A	1	
11	F31376G30AP	HOOK LEVER B	1	
12	F31386G30AP	HOOK LEVER C	1	
13	F400A9L00XP	FAN MOTOR	1	
14	F4008-1L70	FAN BLADE	1	
15	F64377J70XP	GLASS	1	
19	F41449M60BP	UPPER ORIFICE	1	
20	F4146-1P00	LOWER ORIFICE	1	
21	F612E9L60XP	INCANDESCENT LAMP (U)	1	
22	\triangle J61415G10XN	MICRO SWITCH	1	(PRIMARY LATCH SWITCH)
23	\triangle F61415U30XN	MICRO SWITCH	1	(SECONDARY LATCH SWITCH)
25	\triangle F61785U30XN	MICRO SWITCH	1	(SHORT SWITCH)
26	\triangle 2M261-M32J5P	MAGNETRON	1	
29	\triangle A62304210BP	FUSE	1	10A/250V
31	F607X9M50QP	NOISE FILTER (U)	1	
32	F81247Q70BP	BREAKWATER	1	
34	F61449M60BP	STIRRER MOTOR	1	
35	\triangle F900C9M50QP	AC CORD W/PLUG	1	
40	F630G9M50QP	HEATER	2	
41	F1161-1P00	REINFORCEMENT BRACKET A	1	
42	F11659M60BP	REINFORCEMENT BRACKET B	1	
43	F61456V50HP	THERMAL CUTOUT	1	
44	F61457J70XP	THERMAL CUTOUT	2	
47	XTWBF4+8D	SCREW	4	FOR CABINET BODY
48	XTT4+8RDN	SCREW	4	FOR MAGNETRON
49	F22379M60BP	LEFT HEATER PANEL	1	
50	F22369M60BP	RIGHT HEATER PANEL	1	
51	F40279M60BP	INVERTER AIR GUIDE	1	
52	F606Y6Y40BP	H.V. INVERTER (U)	1	
53	F6074-1P00	INCANDESCENT LAMP BRACKET	1	
54	F65859L00XP	INVERTER BRACKET	1	
58	F03349M50QP	MENU LABEL	1	
61	F01505R00BP	NO TOUCHING LABEL	1	
63	F01508G60HP	NO TOUCHING LABEL	1	
65	F22189M50QP	UPPER HEATER PANEL	1	
68	F10599M60BP	BACK COVER	1	
69	F10589M60BP	SIDE COVER	1	
71	F40307Q70BP	AIR GUIDE D	1	
72	F64609M50QP	HEATER MOUNTING PLATE	2	
74	F22397Q70BP	CONVECTION FAN BLADE	1	
75	F41594V00BP	COOLING FAN BLADE	1	

Ref. No.	Part No.	Part Name & Description	Pcs/Set	Remarks
79	F41809M60BP	CONVECTION FAN BRACKET	1	
80	F490S6Y40XP	CONVECTION FAN MOTOR	1	
81	F631D7Q70BP	CONVECTION HEATER	1	
82	F64174V00BP	HEATER BRACKET A	1	
83	F66797Q70BP	CONVECTION INSIDE COVER	1	
84	A22429M60BP	ADIABATIC MATERIAL	1	
85	F66807Q70BP	CONVECTION OUTSIDE COVER	1	
86	A67359M50QP	HEATER PROTECTOR	1	
87	F40667Q70BP	EXHAUST GUIDE D	1	
88	F20999L70XP	REINFORCEMENT BRACKET D	1	

10.3. ESCUTCHEON BASE ASSEMBLY

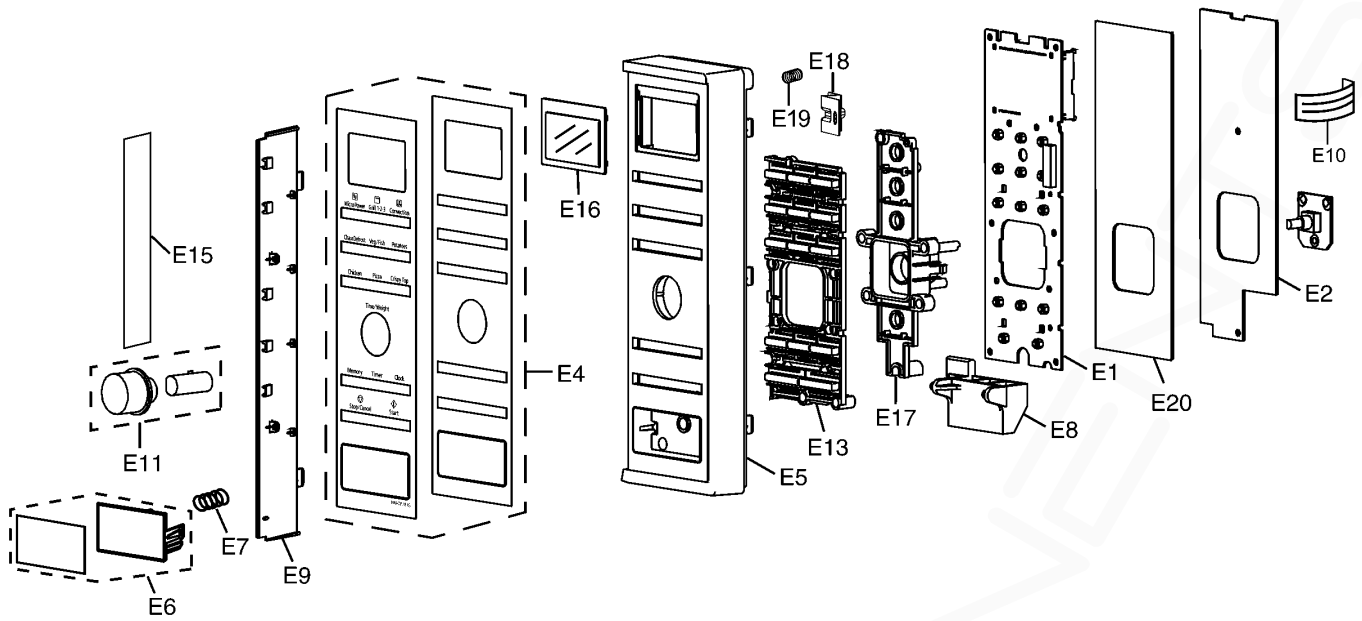

Ref. No.	Part No.	Part Name & Description	Pcs/Set	Remarks
E1	F603L9M50QP	D.P.CIRCUIT (AU)	1	
E2	F603Y9M60BP	D.P.CIRCUIT (DU)	1	
E4	F630N9N00SQP	SUS COVER (U)	1	
E5	F80349N00SBP	ESCUTCHEON BASE	1	
E6	F891P9N00SBP	DOOR OPENING BUTTON (U)	1	
E7	F80375K00AP	COOK BUTTON SPRING	1	
E8	F82569M60BP	DOOR OPENING LEVER	1	
E9	F80579N00SBP	ESCUTCHEON BASE B	1	
E10	F66168J00XP	FLAT CABLE	1	
E11	F803G9N00SBP	POP-OUT DIAL (U)	1	
E13	F82989N00SBP	BUTTON	1	
E15	F01579N00SQP	NAME PLATE	1	
E16	F81269M60BP	LCD DISPLAY WINDOW	1	
E17	F80189M60EP	DIAL SUPPORT	1	
E18	F90099N00BP	GROUNDING PANEL	1	
E19	F80877X50BP	SPRING	1	
E20	F60709M50QP	INSULATION SHEET	1	

10.4. DOOR ASSEMBLY

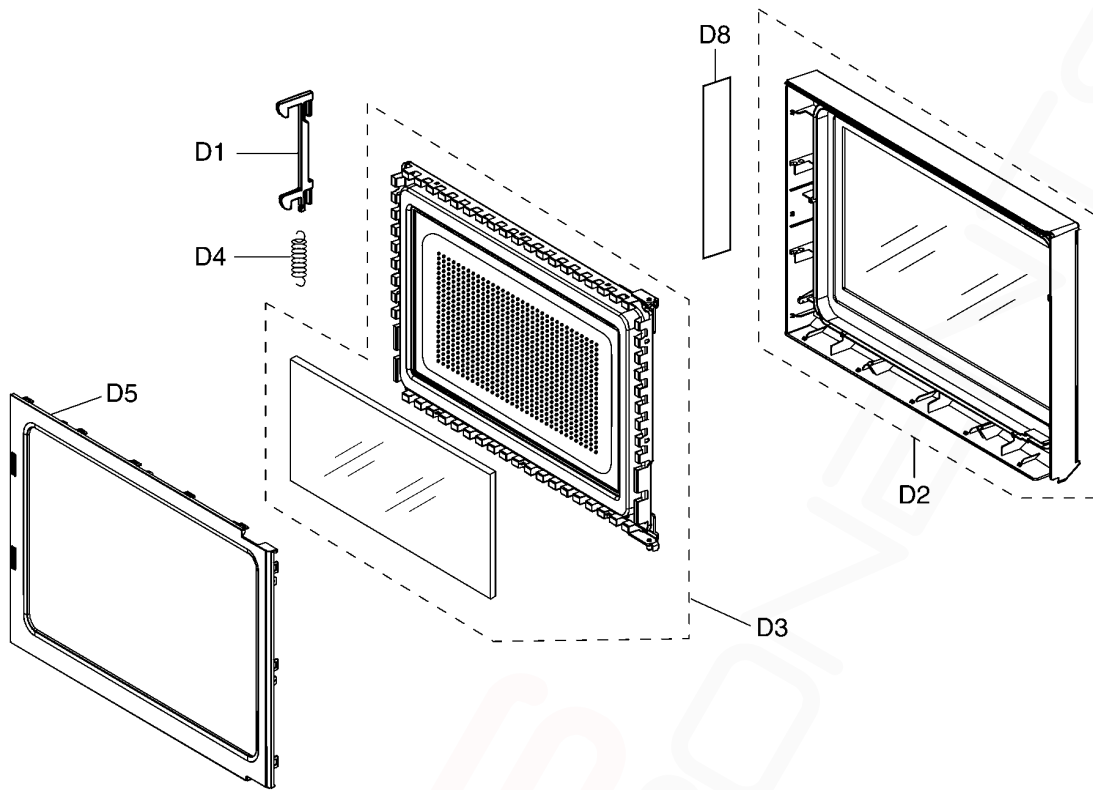

Ref. No.		Part No.	Part Name & Description	Pcs/Set	Remarks
D1		F30186P40AG	DOOR KEY A	1	
D2	△	F302A9N00SQP	DOOR A (U)	1	
D3	△	F301P9M60BP	DOOR E (U)	1	
D4		F30215G10XN	DOOR KEY SPRING	1	
D5	△	F30859Q30AP	DOOR C	1	
D8		F01726V00JP	CAUTION LABEL B	1	

10.5. WIRING MATERIALS

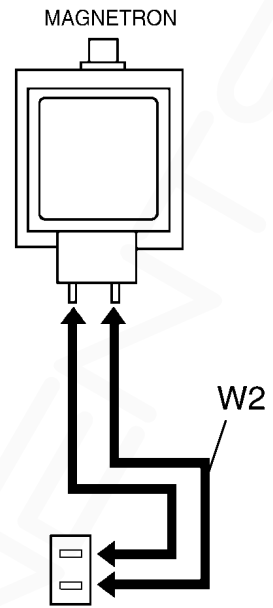
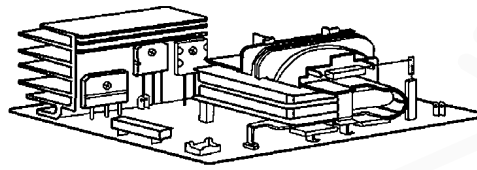
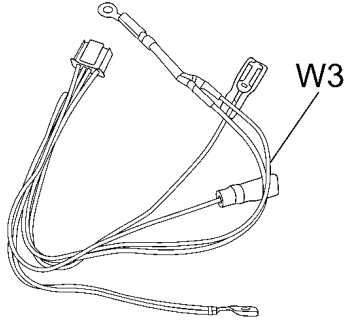
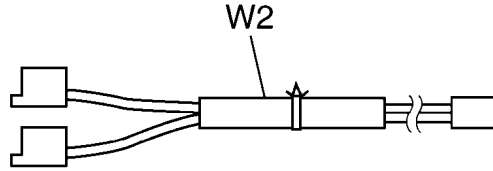
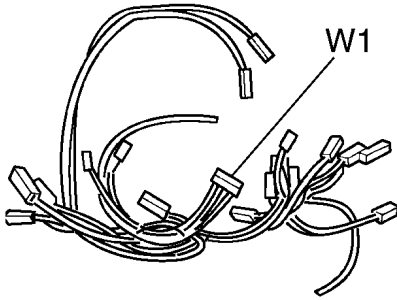

H.V. INVERTER (U)

Ref. No.	Part No.	Part Name & Description	Pcs/Set	Remarks
W1	F030A9M50QP	LEAD WIRE HARNESS	1	(INCLUDING OVEN TEMP SENSOR & MAGNETRON THERMISTOR)
W2	F030E-1P00	H.V.LEAD WIRE	1	
W3	F03877R00SP	LEAD WIRE HARNESS U	1	