

DIM.	TOL
5mm DOWN	±0.2
5~20mm	±0.3
20~40mm	±0.4
40~60mm	±0.5
60~100mm	±0.8
100mm UP	±1.0

MOUNTING HOLE $\phi 3$
THICKNESS 1.2~2.0mm

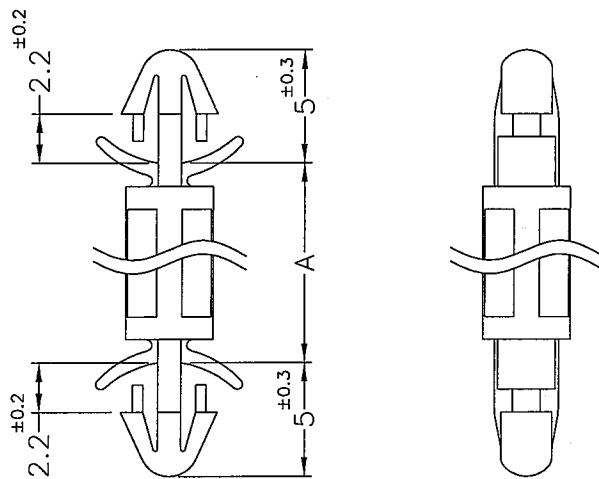

MOUNTING HOLE $\phi 3$
THICKNESS 1.2~2.0mm

PART NO.	A
LCF-3	3.2
LCF-4	4.0
LCF-5	5.0
LCF-6S	6.0
LCF-6	6.35
LCF-8	8.0
LCF-9	9.5
LCF-10.6	10.6
LCF-11	11.2
LCF-12	12.0
LCF-14.4	14.4
LCF-15	15.0
LCF-16	16.0
LCF-17	17.0
LCF-20	20.2
LCF-22	22.0
LCF-25	25.4

NOTE: 1. SHRINKING IS NORMAL STATUS.
內縮為正常現象。
2. MADE OF EQUIVALENT MATERIAL.
均可使用同等材質。



K
ISO 9001
ISO 14001
QC 080000
IATF 16949

康揚企業股份有限公司
KANG YANG HARDWARE ENTERPRISE CO., LTD.
康揚塑膠(東莞)有限公司
KANG YANG PLASTIC(DONG GUAN)CO.,LTD.
康哲電腦配件(吳江)有限公司
KANG CHE COMPUTER COMPONENTS(WUJIANG)CO.,LTD.

PROPRIETARY AND CONFIDENTIAL THE INFORMATION CONTAINED IN THIS DRAWING IS THE SOLE PROPERTY OF KANG YANG HARDWARE ENTERPRISE CO. ANY REPRODUCTION IN PART OR AS A WHOLE WITHOUT THE WRITTEN PERMISSION OF KANG YANG HARDWARE ENTERPRISE CO. IS PROHIBITED. DO NOT SCALE DRAWING	DATE	1999.08.26	TITLE	SPACER SUPPORT		DWG. NO.	LCF-H		PART NO.	SEE ABOVE	
	DRAWN	JASON	MATERIAL	NYLON 66 UL94V-2		SIZE	A4		SPEC. DWG	REV F	
	CHECKED	林祺翔	COLOR	NATURAL	FINISH						
	APPROVED	Kang		UNLESS OTHERWISE SPECIFIED TOLERANCE: SEE ABOVE		SCALE: 3:1	UNIT	mm	SHEET 1 OF 1		